

B. E. STECHBART

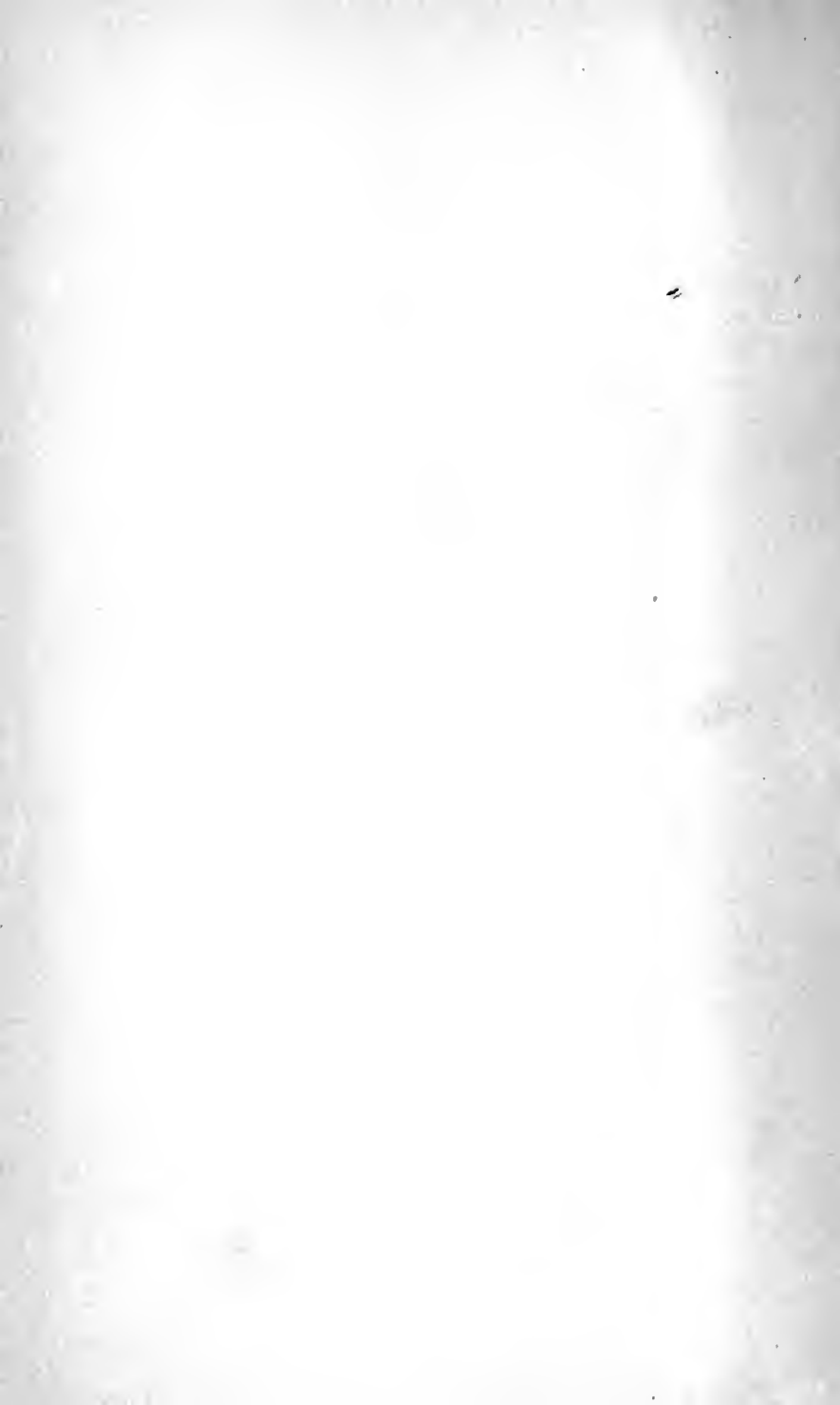



JOURNAL

OF THE SOCIETY OF

MOTION PICTURE ENGINEERS

Volume XXXIV

January, 1940

CONTENTS

	<i>Page</i>
Report on the Adaptation of Fine-Grain Films to Variable-Density Sound Technics.....	3
Improvement in Sound and Picture Release Through the Use of Fine-Grain Film..... C. R. DAILY	12
Photographic Duping of Variable-Area Sound..... F. W. ROBERTS AND E. TAENZER	26
A Sound-Track Center-Line Measuring Device..... F. W. ROBERTS AND H. R. COOK, JR.	38
Starting Characteristics of Speech Sounds..... R. O. DREW AND E. W. KELLOGG	43
Volume Distortion..... S. L. REICHES	59
Lenses for Amateur Motion Picture Equipment..... R. KINGSLAKE	76
Report of the Standards Committee.....	88
Report of the Studio Lighting Committee.....	94
The Importance of Coöperation between Story Construction and Sound to Achieve a New Personality in Pictures..... L. L. RYDER	98
New Motion Picture Apparatus	
A Multiduty Motor System..... A. L. HOLCOMB	103
Current Literature.....	114
Book Review.....	116
1940 Spring Convention at Atlantic City, N. J., April 22nd-25th, Inclusive	117
Society Announcements.....	120

JOURNAL OF THE SOCIETY OF MOTION PICTURE ENGINEERS

SYLVAN HARRIS, EDITOR

Board of Editors

J. I. CRABTREE, *Chairman*

A. N. GOLDSMITH

A. C. HARDY

H. G. KNOX

J. G. FRAYNE

L. A. JONES

G. E. MATTHEWS

E. W. KELLOGG

Subscription to non-members, \$8.00 per annum; to members, \$5.00 per annum, included in their annual membership dues; single copies, \$1.00. A discount on subscription or single copies of 15 per cent is allowed to accredited agencies. Order from the Society of Motion Picture Engineers, Inc., 20th and Northampton Sts., Easton, Pa., or Hotel Pennsylvania, New York, N. Y.

Published monthly at Easton, Pa., by the Society of Motion Picture Engineers.

Publication Office, 20th & Northampton Sts., Easton, Pa.

General and Editorial Office, Hotel Pennsylvania, New York, N. Y.

West Coast Office, Suite 226, Equitable Bldg., Hollywood, Calif.

Entered as second class matter January 15, 1930, at the Post Office at Easton, Pa., under the Act of March 3, 1879. Copyrighted, 1940, by the Society of Motion Picture Engineers, Inc.

Papers appearing in this Journal may be reprinted, abstracted, or abridged provided credit is given to the Journal of the Society of Motion Picture Engineers and to the author, or authors, of the papers in question. Exact reference as to the volume, number, and page of the Journal must be given. The Society is not responsible for statements made by authors.

OFFICERS OF THE SOCIETY

- * *President:* E. A. WILLIFORD, 30 East 42nd St., New York, N. Y.
- * *Past-President:* S. K. WOLF, RKO Building, New York, N. Y.
- * *Executive Vice-President:* N. LEVINSON, Burbank, Calif.
- ** *Engineering Vice-President:* D. E. HYNDMAN, 350 Madison Ave., New York, N. Y.
- * *Editorial Vice-President:* J. I. CRABTREE, Kodak Park, Rochester, N. Y.
- ** *Financial Vice-President:* A. S. DICKINSON, 28 W. 44th St., New York, N. Y.
- * *Convention Vice-President:* W. C. KUNZMANN, Box 6087, Cleveland, Ohio.
- * *Secretary:* J. FRANK, JR., 356 W. 44th St., New York, N. Y.
- * *Treasurer:* R. O. STROCK, 35-11 35th St., Astoria, Long Island, N. Y.

GOVERNORS

- * M. C. BATSEL, Front and Market Sts., Camden, N. J.
- * J. A. DUBRAY, 1801 Larchmont Ave., Chicago, Ill.
- ** A. N. GOLDSMITH, 444 Madison Ave., New York, N. Y.
- ** H. GRIFFIN, 90 Gold St., New York, N. Y.
- * P. J. LARSEN, 29 S. Munn Ave., East Orange, N. J.
- * L. L. RYDER, 5451 Marathon St., Hollywood, Calif.
- ** A. C. HARDY, Massachusetts Institute of Technology, Cambridge, Mass.
- * H. G. TASKER, 14065 Valley Vista Blvd., Van Nuys, Calif.

* Term expires December 31, 1940.

** Term expires December 31, 1941.

REPORT ON THE ADAPTATION OF FINE-GRAIN FILMS TO VARIABLE-DENSITY SOUND TECHNIC^{*}

Summary.—*The activities of various West Coast studios and laboratories in the adaptation of fine-grain films for variable-density recording are summarized. A set of requirements for a suitable variable-density negative and print emulsions have been formulated and are included in the paper.*

Since the latter part of 1938 and continuing up to the present time, considerable experimentation has been carried on by Electrical Research Products, Inc., and several of the Western Electric recording licensees with a view to utilizing some of the fine-grain emulsions for variable-density negative and re-recording print use with the expectations that such films would be much freer from background noise, and at the same time provide better sound quality than that obtainable from standard positive type emulsions. The Metro-Goldwyn-Mayer Studio, after a thorough investigation of various fine-grain emulsions, have adopted the type 222 stock furnished by the Dupont Film Manufacturing Corporation for all original negative and print material, as well as for the re-recorded negative. Several pictures have been released in which fine-grain film has been used in some of the processes leading up to the release print. At the Samuel Goldwyn Studios considerable tests were carried out on various experimental emulsions offered by Dupont and by the Eastman Kodak Company, as well as on some of the standard fine-grain emulsions offered by both these suppliers. The recording tests made by this studio were confined to original negatives and re-recording prints of scoring, and some of this material has been utilized in pictures that have been already released. For some time all re-recording prints at Paramount have been made on the 222 stock from a normal sound negative and one complete picture has been re-recorded to fine-grain release negative with a limited number of release movietone prints also being printed on the 222 stock. This represents the first complete adaptation of fine-grain stocks to release. The Universal Studio made some scoring and dialog tests on the 1365 stock

^{*} Presented at the 1939 Fall Meeting at New York, N. Y.; received October 13, 1939.

furnished by the Eastman Kodak Company, with prints being made on the same material.

Simultaneously with this program in the studios, Electrical Research Products, Inc., has been active in a fundamental investigation of the sensitometric properties and the signal-to-noise relationships of all the available fine-grain emulsions, with a view to giving the results to its recording licensees for such value as they might have in the working out of variable-density recording programs. In order to correlate the activities of these diverse groups, a Committee of representatives from the Western Electric Recording licensees, the major film suppliers, and Electrical Research Products, Inc., was formed in February of this year. The exchange of information between the various members participating in these Committee meetings has tended to eliminate a lot of duplicate efforts that would otherwise be inevitable under such circumstances. The Committee also set about to draw up a set of requirements for an ideal fine-grain variable-density negative and re-recording print stock. These requirements, listed in an Appendix to this report, were submitted to the representatives of the major film suppliers in May of this year. As will be noted from the Appendix, the attention of the Committee was confined to securing films more suitable for those processes which did not in any way conflict with quality of the picture as finally seen on the screen. Thus, the specifications are confined to original sound negative, original or re-recording print, and re-recording negative; a special provision being incorporated that the new stock when used as a re-recording negative must be capable of being printed onto present type release stocks developed in the standard manner.

The interest in the use of fine-grain films for variable-density recording has been due to the possibility that these films might offer a considerable reduction in the background noise existing in present standard stocks, and at the same time reduce the intermodulation of noise and signal. While considerable progress has been made in the use of noise-reduction circuits to enhance the apparent signal-to-noise ratio on standard stocks, it has been felt that a reduction in noise in the film itself is essential to accommodate fully the volume range obtainable in modern sound recording systems. Further, while the use of noise-reduction circuits has made possible an increase in apparent signal-to-noise ratio on standard stocks, the quality of the recorded sound tends to become impaired when noise reduction in excess of 10 db is applied, for beyond this point the breathing of the background noise

tends to offset the benefits accruing from increased quietness during silent passages.

Theoretical and experimental considerations have for some time led to the belief that reduction in the graininess of the negative and the positive sound stocks would assist in reducing background noise, and thereby enhance the signal-to-noise ratio attainable from sound-on-film; but until quite recently no fine-grain films that could be considered at all suitable for variable-density recording have been available. In 1937 a fine-grain sound emulsion was introduced by Eastman as type 1360 which, when exposed by white light, was intended for direct positive recordings as a substitute for the then current technic of ultraviolet exposure on standard sound negative emulsions in the variable-area system. Dupont also introduced their type 216 for the same purpose. Both these films were primarily designed for variable-area work and with their inherently high contrast were not particularly suitable for variable-density low-gamma negative development. Early in 1939 Dupont introduced type 222, referred to previously, for variable-density negative and re-recording print use. The Eastman 1365, referred to previously, was actually introduced in 1937 as a fine-grain duplicating positive, but due to its low speed, was not considered at that time as suitable for variable-density recording.

One of the problems confronting the use of any type of fine-grain emulsion for variable-density recording is the relatively low speed of these emulsions. In this connection it should be recalled that the use of standard sound emulsions in existing recording units calls in many cases for the maximum exposure obtainable from a tungsten lamp operated at its normal temperature. Consequently, with fine-grain films being offered with a speed of about one-tenth that of standard films, either a new light-source or drastic improvement in efficiency of old light-sources and optical systems becomes an obvious necessity. Fortunately, the development of the high-pressure mercury arc with a high intrinsic brilliance offers a possibility in this connection. The problem of securing sufficient exposure is not confined to the negative, but is also involved in securing sufficient exposure of the print. The high-pressure mercury lamp has been found to be the most suitable source for use in printing these stocks and several laboratories on the West Coast either are completely equipped or are in process of being equipped, with these light-sources.

The high-pressure mercury arc as originally offered by the suppliers

was not satisfactory as a sound recording medium due to the inherent high arc noise. After a series of coöperative tests between engineering groups in the studios and laboratories in Hollywood, the lamp has been brought to a high state of efficiency and may now be considered a satisfactory source of exposure for many of the existing fine-grain films. Further recent modifications have been made in this lamp by several of the Hollywood studios to provide greater illumination than can be obtained by using it in its normal state. Thus, forced-air cooling of the arc (usually done by connecting a small intake tube at the end of the bulb and making a small opening in the outer envelope near the base and permitting a stream of air to pass the enclosed quartz arc) makes possible a considerable increase in illumination by operation at higher wattage than that for which the lamp was originally designed. This air-cooling device is being successfully employed at several studios and permits a range of exposure that could not have been obtained from the lamp without such air cooling.

The use of the standard tungsten lamp as a source of exposure for these fine-grain stocks appears to offer possibilities in connection with the use of certain optical systems and under certain conditions of development. Thus, for some time M.-G.-M. have been using a standard tungsten source at or slightly above its normal temperature rating for all original recording, while the same studio employs the mercury arc for recording the release negative where a higher negative density is required. Further, recent improvements in developers for use with low-gamma fine-grain negatives at the Paramount and M.-G.-M. West Coast Laboratories indicate that with improved recording optics, combined with ultraviolet printing, it may be quite feasible to substitute completely the use of a standard tungsten-filament source for exposure of these films.

Sufficient experimentation backed up by actual studio recordings have been made to indicate the order of magnitude of the improvements that may be expected from the adoption of fine-grain film, both as a variable-density negative and a positive. Thus, an improvement in signal-to-noise ratio, as measured in accordance with Section 6 of the attached specifications, of at least 6 db is indicated on a fine-grain print made from a fine-grain negative. It should be pointed out, however, that the actual improvement to the ear seems more of the order of 8 to 10 db, this being accounted for largely by the almost complete absence of breathing of the background noise. While

one studio, using the 200-mil push-pull system, reports a satisfactory signal-to-noise ratio from fine-grain films without any applied noise-reduction, others using the standard system report that the use of a normal amount of noise-reduction may be associated with fine-grain film recording with highly satisfactory results. Laboratory measurements report that with a fine-grain stock, such as Dupont 222 or equivalent, a total signal-to-noise ratio of 45 db may be obtained. With the finer-grained Eastman 1365 this figure may be increased to about 48. Recording tests show that with the application of 10 db of noise-reduction to films of this nature, excellent quality of both dialog and music may be obtained.

While the ultimate benefits from the use of fine-grain film can be obtained only by carrying the fine-grain all the way to the release print, considerable improvement in signal-to-noise ratio and in overall quality can be obtained by using it for original negative, re-recording print, and re-recorded negative, with the final print being made on a standard positive stock. In the latter case the noise and modulated noise effects appear to increase by 3 to 5 db in comparison with a fine-grain print. Considerable success has been found in the Hollywood studios from the use of fine-grain film for original negatives and re-recording prints only; the tendency, however, is to carry the fine-grain also to the re-recording negative stage.

The improvements from the use of fine-grain film in variable-density recording are not confined to increased signal-to-noise ratio, but include other factors such as improved image definition which may be traced to reduced flare in the emulsion. This results in a cleanliness of all high-frequencies not hitherto attainable, and is also accompanied by a moderate increase in the high-frequency output in such films as compared to standard films. A very low degree of distortion is indicated, when measured by intermodulation or harmonic analysis, on fine-grain prints made from fine-grain negatives, especially if ultraviolet light is used in exposing the print stock. This low distortion undoubtedly is partially responsible for the pleasing quality of recordings made on fine-grain films.

To obtain satisfactory results with current fine-grain stocks, dynamic methods are recommended for determination of optimum processing conditions, as misleading information may result from the application of classical sensitometry to these films. The use of these films under laboratory conditions generally calls for the exercise of greater care in processing and handling in order to avoid noise from

dirt and abrasions. Such noise is more evident on these films due to lack of masking by the lower background noise inherent in these stocks. One of the chief problems presented with the use of these films has been that of being able to obtain a sufficiently low negative gamma, and at the same time obtain the required negative density. This has required a development of suitable negative baths. While the low speed of these films may still be considered a problem, the improvements in light-sources as well as in optics indicate that present fine-grain stocks or future ones, even more slow, may be exposed without any great difficulty. In spite of the difficulties attendant to the introduction of fine-grain film in the sound-recording field, the improvement in signal-to-noise ratio and in general quality mean their inevitable introduction on a wide scale into the motion picture industry.

JOHN G. FRAYNE, *Chairman*
Fine-Grain Film Committee

L. A. AICHOLTZ, Universal Studio
F. G. ALBIN, Samuel Goldwyn Studio
G. M. BEST, Warner Bros. Studio
G. A. CHAMBERS, Eastman Kodak Co.
C. R. DAILY, Paramount Studio
J. K. HILLIARD, M.-G.-M. Studio
W. W. LINDSAY, JR., G. S. S. I.
H. W. MOYSE, Dupont Film Mfg. Corp.
K. M. PIER, 20th Century-Fox Studio
S. J. TWINING, Columbia
ELMER RAGUSE, Hal Roach Studio

APPENDIX

SPECIFICATIONS FOR AN IMPROVED VARIABLE-DENSITY SOUND NEGATIVE AND A RE-RECORDING PRINT STOCK

These specifications cover a negative stock to be used for original recording and for release recording; also a print stock primarily intended for use as a re-recording print stock. It will be satisfactory if a single emulsion can satisfactorily fulfill the requirements as a negative and re-recording positive.

These specifications do not apply to release positive film, although a number of the requirements listed below pertain to such a new film when it is designed.

(1) *Intended Usage*.—These films are intended for variable-density recording, assuming a white-light source of exposure for both negative and positive.

(a) The negative is intended for original recording and re-recording operations.

(b) The print stock is primarily intended for re-recording prints.

(2) *Gamma Infinity*.—(a) Negative stock gamma-infinity may be as low as 1.0 and not greater than 2.0, assuming development in present variable-density sound-track negative developers.

(b) The re-recording print stock gamma-infinity should be such that a value of approximately 2.0 may be readily obtained with existing motion picture positive developers.

(3) *Development Requirements.*—(a) The new negative stock when used for original recording must be capable of being printed onto the new re-recording print stock and attain a projected overall gamma of unity.

(b) The new negative stock when used as a re-recording negative must be capable of being printed onto the present types of release stocks which will be developed in standard release positive developers; again attaining a projected overall gamma of unity.

(c) The new original sound negative must be capable of being printed directly to the release positive stock with a projected overall unity.

(4) *Speed and Light Sources.*—For the purpose of this specification, the speed of variable-density sound negative will be defined as the log E value on an Eastman IIb sensitometric scale, corresponding to the toe break of the H&D curve.

(a) It is desirable that the speed of the negative be such that it may be correctly exposed using unfiltered tungsten sources operating at color temperatures less than 3000°K in connection with existing recording optical systems. If, however, in order to meet the requirements of Section 6 below, it is found necessary further to reduce the speed, then a G. E. H3X mercury lamp, or equivalent, unfiltered may be considered as a source of exposure for the film.

(b) Both unfiltered tungsten and unfiltered mercury lamp sources may be considered suitable for the printing operation.

(5) *Latitude.*—The latitude of the straight-line portion of the H&D curve used either as negative or positive should have a log E value of at least 1.3.

(6) *Signal-to-Noise Ratio.*—(a) Prints made on the new re-recording print stock from the new negative stock should show an increase in signal-to-noise ratio of 8 to 12 db over that now found in existing sound positives made from existing sound negatives.

(b) Release prints made on the E. K. 1301 or Dupont 213 from the new sound negative should show an increase in the signal-to-noise ratio of 4 to 6 db over existing prints made from existing negatives.

(c) *Method of Measurement.*—The measurement of the signal-to-noise ratio for a given stock should be made, using a normal theater reproducing system whose frequency characteristic referred to constant modulation of the light in the reproducing aperture represents the ear-weighting characteristic equivalent to the 40 db loudness contour. The characteristic of this contour as adopted by the American Standards Association is as follows:

F	Relative Response
60	−27.0 db
100	−19.0
300	− 7.0
500	− 3.5
1000	0
3000	+ 3.0
5000	+ 0.5
8000	− 3.5

The scanning width of the reproducing aperture is assumed to be the normal 84 mils.

The maximum signal output of a print is defined as the reproduced 1000-cycle output, assuming 100 per cent modulation of the recording modulating device. The output at 100 per cent modulation may be obtained by extrapolation from the measured output obtained from a 50 per cent modulation of the recording mechanism.

The film-noise distribution throughout the spectrum should be relatively smooth, that is, it should not have a predominance of noise in any restricted frequency band. A check of such a condition can be made employing suitable band-pass filters. A qualitative check of noise may be made by projecting the films over a normal theater reproducing system.

(d) Signal-to-noise ratios as measured above indicate values of 40 to 42 db for white-light prints on E. K. 1301 or Dupont 213 from E. K. 1359 or Dupont 214 negatives developed in normal positive and sound negative developers.

(7) *Image Spread—Halation.*—The film should be free of image spread when exposed under sound-recording conditions to either mercury arc or unfiltered tungsten light. In testing for image spread, the size and intensity of the light-source should simulate a light-valve as used for variable-density recording producing an image height of approximately 0.25 mil. Gray base or a fugitive dye may be used if necessary to obtain freedom from halation.

(8) *Image Stability.*—Over any period of time the new film should hold an exposed undeveloped latent image as well as E. K. 1359 or Dupont 214.

(9) *Durability.*—The wearing qualities of the film with normal handling should be at least as good as that obtained with E. K. 1369 or Dupont 214.

DISCUSSION

MR. KELLOGG: Do I understand that the comparisons reported were between the ground-noise with the fine-grain film as compared with standard sound-recording stocks, when exposed with white light or ultraviolet?

MR. MORGAN: They were exposed to unfiltered mercury arc light.

MR. KELLOGG: If you have got to go to a mercury lamp to expose the fine-grain stocks, it might be reasonable to compare the fine-grain recording with standard film exposed with ultraviolet. The ultraviolet cuts down the graininess of standard recording film so much that there might be little to choose.

MR. PALMER: So much progress has been made in improving the quality of sound by the use of these very fine-grain emulsions that it suggests the possibility that it might be advisable to record sound on a color-sensitive film in which the film image is a dyed image instead of a silver-grain image, and still further improve the quality of the sound.

MR. MORGAN: That has been talked about. I do not know whether anyone has actually made tests. The thing that everyone is hoping that these developments will accomplish is, of course, improved sound quality; but, in addition to that, a greater signal-to-noise ratio, making possible original recordings without the necessity of volume control. That would provide much greater latitude in the re-recording process; and even though it may be necessary to compress the volume range somewhat in the release print, a much better and more dramatic re-

sult can be had if the originals are as near like the sound that occurred on the stage, in both volume and quality.

MR. CRABTREE: I think this development indicates that if there is the remotest possibility that any new idea will improve the quality of the sound or the picture, the Hollywood technicians are willing to expend the necessary time and money to try it out. This is very encouraging to those engaged in research who have proposed so many things in the past only to be literally sat upon because the new proposals involved changes in equipment or the expenditure of money.

MR. MAURER: It appears that in the minds of most of us the principal reason for using fine-grain films is that they give reduced background noise. In this connection, and in view of what Mr. Crabtree has just said, I should like to call attention to one factor that has not been discussed here. That is the importance of dirt as a source of background noise when the noise due to film graininess has been largely eliminated.

About nine years ago I was working on a problem that required the reduction of film background noise to an exceptionally low point. In the course of that work I made use of one of the earliest types of these ultra-fine-grain recording films. After having reduced the noise by all the ordinary technics known at the time, on standard film, I substituted the fine-grain film and found a reduction in noise of the order of eight decibels.

Thereafter, somewhat by accident, I discovered that by taking altogether exceptional precautions to obtain freedom from suspended matter in the water used to wash the films, and in the developing and fixing solutions, a further reduction in noise of the same order of magnitude could be obtained. But this improvement in background noise was not obtained by taking similar precautions in the processing of standard, or coarse-grain, films.

I bring up the point at this time because the evidence from the work I did was so definite, so unmistakable, that, in spite of the fact that no one has reported any similar observations in the intervening time, I am still convinced that in a technic in which we reduce the noise that is inherent in the film itself to a low point, we ought to begin taking greater care than the industry has ever thought worth while in filtering the wash water and all chemical baths, and in the removal of dust from the air used to dry the films.

DR. FRAYNE:* Answering Mr. Kellogg, measurements of signal-to-noise ratio on standard film exposed to ultraviolet light show an improvement of approximately one db over that obtained in the same film when exposed to ordinary tungsten light. This is a negligible improvement compared to that reported from the use of fine-grain films.

The points raised by Mr. Maurer have been given a great deal of attention by the Hollywood film laboratories and considerable success has been attained in reducing "pops" and other undesirable noises that were unmasked when the film background noise was reduced by the use of fine-grain film stocks. With regard to Mr. Maurer's claim that he successfully used an ultra-fine-grain recording film some nine years ago, it is a matter of regret that he did not proclaim this discovery from the housetops and thereby assist in solving one of the industry's most pressing problems.

* Communicated.

IMPROVEMENT IN SOUND AND PICTURE RELEASE THROUGH THE USE OF FINE-GRAIN FILM*

C. R. DAILY**

Summary.—Many types of picture scenes are improved in quality when some of the new fine-grain films are used as a printing stock. More detail on the screen and less image "boiling" is observed due to the greater resolution of the fine-grain films. When such films are used for variable-density sound recording, a material increase in volume range is obtained which permits greater latitude in the original and dubbing recording operations. The sound quality is improved due to the reduction in noise and modulated noise effects which partially mask the signal when the coarser-grained positive types of emulsions are used. Data are presented on some of the problems encountered in the use of fine-grain films for dubbing prints, release negative, and release prints.

The need of finer-grained film stocks for release use has been felt for some time because of the recognized limitations of the older positive type emulsions. This paper describes the methods recently developed and perfected at Paramount Pictures, Inc., which make possible the commercial use of one of the new fine-grain emulsions for the release sound negative and for the movietone release picture and sound print. The release use of fine-grain films provides a picture image which is improved in definition, the signal-to-noise ratio on the sound print is materially increased and the dramatic value of recorded material enhanced by the reduction of modulated film noise. The completion of this important development now makes possible the full utilization of the benefits of fine-grain films for original and release sound-track and release picture prints, in addition to the present use of such films in making improved master positives, duped negatives, and projection background prints.

Representatives of the sound departments of a number of the studios were instrumental in forming a committee in January, 1939, to draw up specifications for fine-grain films better adapted to variable-density recording than the fine-grain films then available. This

* Presented at the 1939 Fall Meeting at New York, N. Y.; received October 14, 1939.

** Paramount Pictures, Inc., Hollywood, Calif.

Committee, comprised of representatives of E. R. P. I., Dupont, Eastman, M.-G.-M., Paramount, Samuel Goldwyn Studio, Universal, Twentieth Century-Fox, G. S. S. I., Columbia, and Warners, prepared over a period of time a set of specifications which were submitted to the film suppliers. Since a progress report of the activities of this Committee is being presented in a separate paper,¹ it will not be covered here. While most of these organizations initially restricted their experimental work to the application of fine-grain films for original recordings and dubbing prints, the activities at Paramount were independently directed toward the specific problem of applying such films for use as a release sound negative and a release picture and sound print, since it was felt by this studio that only by such an application to release printing could the theater patron be benefited to the greatest possible extent, in regard to both picture and sound.

Emulsion Limitations.—The positive type of film emulsions currently used for variable-density sound negatives, dubbing prints, and release prints have a relatively coarse-grain structure. As a result, sound prints are subject to a considerable amount of film noise, modulated film noise effects, loss of high-frequency resolution, some image spread and halation, and other problems which impair the realism of sound recordings. Picture prints are likewise restricted in definition and clarity. On account of the excellent results obtained with fine-grain films for duplicating and projection background prints, it was logical to expect that a similar improvement would be obtained if suitable films of this type were applied to variable-density sound recording and release picture printing.

Minimizing Film Noise Effects.—Since the basic film noise of positive type emulsions has remained essentially unchanged since the advent of sound pictures, the equipment suppliers and studios have developed a number of devices to reduce the disturbing effects of this noise, such devices including noise-reduction equipments, push-pull recordings, track-matting devices, wider original sound-tracks, and pre- and post-equalized original push-pull recordings. Ultraviolet printing of variable-density sound-track on positive type emulsions, has also been found to reduce slightly the apparent film noise, at the same time improving the high-frequency response and reducing the halation effects. Of the film noise reduction methods pointed out above, ultraviolet printing is the only one which basically affects the source of film noise and this to only a limited degree.

Initial Applications.—Fine-grain duplicating type films were first made available in 1937. They were immediately applied to make master positives, duped negatives, and projection background prints, with a material improvement in quality. The first experimental work on fine-grain variable-density dubbing prints was also undertaken at this time. During the past two years, fine-grain films have also been applied to a limited extent as an original recording and dubbing print stock for variable-area. Since the above-mentioned uses of fine-grain films have been adequately covered in the literature, the discussion in this paper will be limited to the recent application of fine-grain films to variable-density release recording and movietone sound and picture release prints.

General Requirements for Release.—The following general requirements were indicated as desirable in the fine-grain films which would prove of maximum use to this studio at the present time:

(1) Normal release positive developer, with development at approximately the normal time, to be used for the proposed fine-grain movietone release and for fine-grain dubbing prints.

(2) Higher-intensity printing light-sources to be made available if necessary.

(3) Usable as a release sound negative, requiring special exposure and development if necessary.

(4) These requirements indicated a stock which would have a suitably high gamma in the positive developer for the release picture and, in addition, could be developed to a suitable low gamma for the release sound negative.

In addition to the above requirements for the handling of such films, the following benefits were desired:

(1) Picture detail to be improved and the projected color to be satisfactory.

(2) Release sound-track print noise to be materially lower than that obtained with the currently used combinations of positive type emulsions.

(3) Frequency characteristic equal to or superior to that obtained with positive type emulsions.

(4) Overall dynamic distortion of the sound-print to be reduced.

Tests at a number of studios during the early part of 1939 on experimental and existent fine-grain emulsions led to the development of the Dupont 222 type emulsion. Since tests on this particular stock

indicated that, in general, it fulfilled the requirements listed above, experimental work at their studio was concentrated on that particular emulsion in order to work out all the phases of operation necessary for its early application to release. The slowness of the emulsion and apparently greater susceptibility to abrasion and to picking up dirt, however, are problems involved in its use. As would be expected, it is necessary to exercise greater care in keeping the negative clean since the reduced general film background noise makes printed-through dirt noise much more apparent.

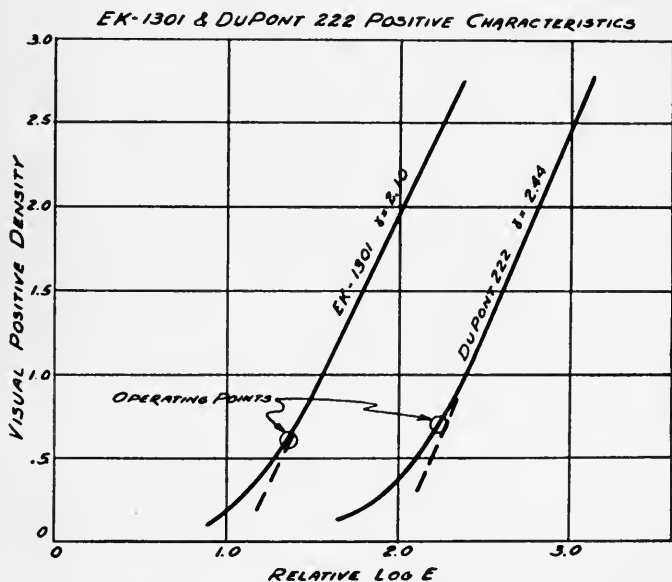

FIG. 1. I**b** sensitometric characteristics of Dupont 222 fine-grain and Ek-1301 positive emulsions in release positive developer; same development time.

The following paragraphs cover some of the technical aspects of the present use of this particular emulsion as applied to release.

Printing.—As an illustration of the lower printing exposure speed of fine-grain film, standard I**b** sensitometric characteristics are shown in Fig. 1 for the 222 and 1301 emulsions when developed at the same time in release positive developer. The circles indicate the approximate visual print densities used for the unbiased printed-through sound-track, (a) for the case where 222 is used as a negative and as a print, and (b) for the case where 1359 is used as a negative

for 1301 prints. The sensitometric $\Delta \log E$ of 0.9 indicated to obtain these densities, corresponds to a ratio of eight in exposure speed. In order to obtain this increase in printing light, Bell and Howell Model *D* printers were first modified by replacing the 165-watt tungsten lamps with General Electric *H3X* mercury arcs operating at approximately 90 watts. Adjustments of the wattage and ground-glasses provided the necessary control to obtain the desired mean exposure. These arcs have proved to be stable in operation and have a long life characteristic. While Model *E* release printers require a still higher intensity light-source, it now appears practicable to equip these machines with suitable mercury arcs for fine-grain printing.



FIG. 2. (a) *H3X* arc modified for forced-air cooling; (b) Normal *H3X* arc.

Release Recording.—Fine-grain films for release sound negative use also required an increase in the intrinsic brilliance of the recorder lamp. In addition, the Western Electric *D-86715* film recording machines used at this studio for release recording are equipped with track-matting devices which still further reduce the exposure obtainable, by comparison with production recorders, on account of the additional optical system employed. Tests on the coiled-filament tungsten lamps normally employed indicated that insufficient exposure could be obtained at a safe operating current. The General Electric *H3X* 85-watt high-

pressure mercury arc was therefore tested as a new light-source and was found to have the following characteristics:

(a) At 90 to 100 watts, the exposure obtained was just sufficient with no margin of added exposure which might be needed to take care of variations in stock and developer sensitivity.

(b) Warm-up time of 5 to 10 minutes required.

(c) Cooling time of approximately 5 minutes required if the arc were accidentally extinguished, before it could be restruck, with a further delay due to the new re-heat time required. Such delays might be quite expensive to production and to overcome them might

require the operation of a spare lamp in a pre-focused mounting.

Development work on the *H3X* arc, modified for forced-draft air-cooling, indicated a number of advantages: (a) Twice the normal exposure obtainable, (b) starting time reduced to one minute or less, (c) no delay in restriking the arc if accidentally extinguished, (d) arc self-extinguishing if air or power supply interrupted. Views of the normal and modified arcs are shown in Fig. 2. A glass tube is sealed

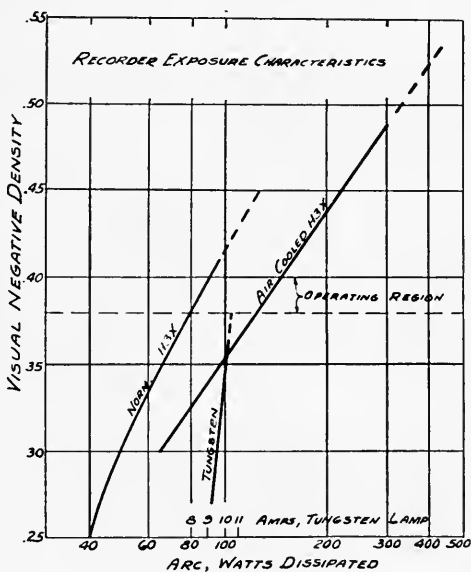

FIG. 3. Exposure characteristics of light-sources for release type Western Electric Recorder. Dupont 222, special negative developer, gamma 0.28; (a) air-cooled *H3X* arc; (b) *H3X* arc; and (c) 9.5-v, 9-ampere coiled-filament tungsten lamp.

to the end of the envelope to permit connection to the compressed-air line, and a small hole added in the envelope near the base of the tube to permit escape of the air.

Fig. 3 shows a comparison of the relative exposures obtained on the release recorder using (a) the normal 9.5-volt, 9-ampere coiled-filament tungsten lamp, (b) the unmodified *H3X* arc, and (c) the air-cooled *H3X* arc. Dupont 222 stock was used for this test, developed to a control gamma of 0.28 in the special borax negative sound developer which had been made up for this work. A visual negative

density of 0.38 to 0.40 was indicated as optimum from distortion data which will be explained later. In order to obtain this density, it would be necessary to operate the 9-ampere coiled-filament lamp at 10.4 amperes, a value too high for safe commercial use. The normal *H3X* arc would be operated at 80 to 100 watts with little margin of safety since these lamps swell and become unusable at higher wattage. The air-cooled arc operating at 120 to 140 watts provides adequate exposure with a margin of safety of at least two times. Tests indicate that it can be operated for considerable periods of time at 200 to 300 watts with only a gradual deterioration of the cathodes.

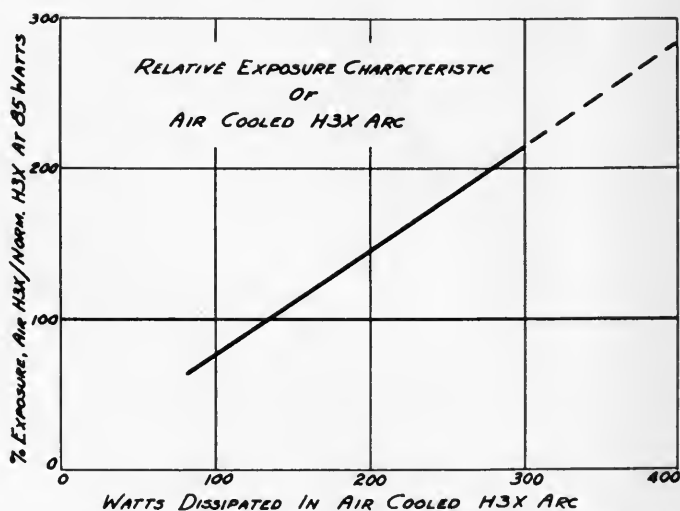

FIG. 4. Exposure of air-cooled *H3X* arc referred to a normal *H3X* arc operated at 85 watts.

The relative wattage-exposure efficiency of the air-cooled arc *vs.* the normal arc is shown in Fig. 4, the data being derived from Fig. 3. This curve indicates that the air-cooled arc required approximately 50 per cent more wattage to be dissipated in order to produce the same exposure as the normal arc operated at 85 watts. The simplified circuit of the air-cooled arc supply is shown in Fig. 5. A 200-volt generator is connected to the arc through a filter circuit and adjustable series resistance *R*. The series inductance termination toward the arc was found desirable to eliminate an occasional tendency of the arc to oscillate at very low frequency when very little series resistance was included in the circuit, and the filter section was termi-

nated by a capacity. The required starting voltage for the arc is being temporarily supplied from a high-voltage rectifier which was available. This starting circuit can be replaced by a high-voltage transformer or other means for striking the arc. The switch Sw_1 is normally closed while the arc is in operation. Since the release recorders are permanently installed, the lot supply of compressed air has been used. A suitable filter inserted in the air-line prevents contamination of the surface of the arc tube and the inside of the protecting glass envelope. An Airco regulator and pressure-meter control the air-pressure. It is important that the flow of air passing the

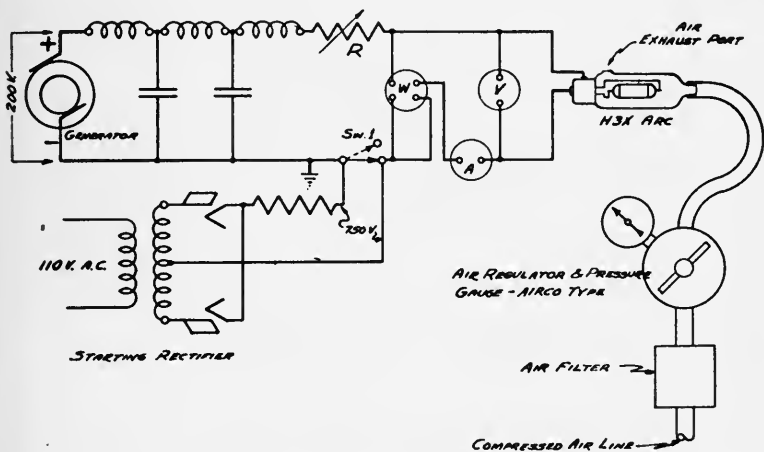

FIG. 5. Control circuit of air-cooled H3X arc.

air-cooled arc be quite stable; otherwise erratic fluctuations in the light output will occur.

The method of starting and operating the air-cooled arc as developed here appears to offer definite advantages over other modes of operation which were tested. The voltage across the arc is not permitted to exceed 150 volts and it is normally operated at 125 volts. This restriction, together with precision control of the air supply, has resulted in a long life with stable exposure.

To start the arc, the air supply is turned off, the resistance R set at a fairly high value, and the switch Sw_1 momentarily opened. The arc starts operating at approximately 0.5 ampere at 10 to 20 volts. R is then reduced until the current approaches 1.5 amperes, the voltage across the arc being approximately 20 volts because the

arc is still fairly cold. During the next 20 to 30 seconds the voltage will rapidly rise, R being adjusted to keep the current less than 1.5 amperes. The air is turned on across the arc when the voltage equals 100 volts, the voltage across the arc never exceeding 150 volts. Simultaneous adjustments are then made of the resistance and the air supply so that the voltage is approximately 125 volts and the wattage approaches the desired value as indicated on the wattmeter W . One arc which has been in service for some time has been started in this manner more than 100 times with no appreciable deterioration. It is normally operated at approximately 140 watts, 125 volts, 1.1 amperes. The air-cooled arc is mounted on the recorder in a special bracket and is enclosed in a protective housing to prevent erratic

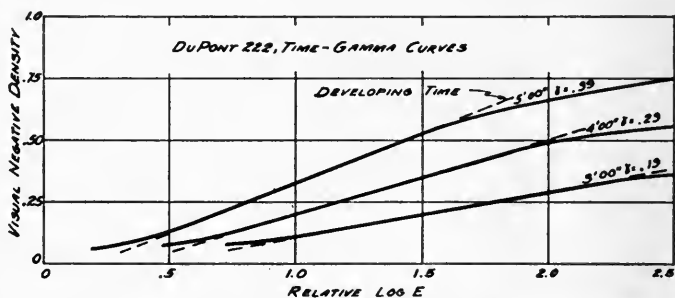

FIG. 6. Dupont 222. Time-gamma characteristics in special negative developer.

cooling from the outside air sources. An arc-welding type glass filter is mounted in the housing to permit ready inspection of the lamp without damage to the eyes of the operator.

New Negative Developer.—Since the objective of this development was to provide a satisfactory fine-grain release positive and a fine-grain release sound negative, the sound negative would have to be developed to a low gamma if a high-quality sound print were to be obtained. Tests on Dupont 222 in the normal sound negative developer indicated a control gamma of approximately 0.5 at the shortest time of development. Since the distortion obtained at this gamma was too high when printed with a mercury arc to Dupont 222 release stock, the group at the Paramount Film Laboratory, under the direction of Messrs. J. R. Wilkinson and F. L. Eich, engineered a special borax sound negative developer which has proved to be very satisfactory for the proper low-gamma development of Dupont 222.

Fig. 6 shows the IIb sensitometric time-gamma characteristics of 222 stock in this new developer, the developer being used in a normal sound negative developing machine. A visual control gamma of 0.27 has been found to be optimum for the 222 negative when prints, as indicated above, are made on 222 stock and handled in the normal release developer.

Fig. 7 is shown to indicate the difference in density of sensitometric exposures obtained on (a) Dupont 222 when handled in the special developer and (b) EK-1359 sound negative stock developed in the normal sound negative developer. The operating visual control gammas are 0.27 and 0.35, respectively. An increase in sensito-

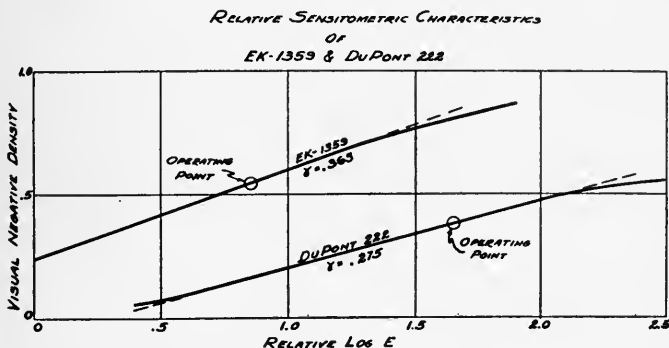

FIG. 7. IIb sensitometric characteristics of (a) EK-1359 in normal negative sound developer; (b) Dupont 222 fine-grain in special negative sound developer.

metric exposure of approximately seven times is indicated in order to obtain the desired operating density on the fine-grain stock. The circled operating points are the approximate normal values used in production. The 1359 negative is normally printed with white-light to 1301 while the 222 stock is printed with a mercury arc to 222, both prints being handled in the normal positive developer.

Processing Controls.—Tests on 222 as a picture print stock indicated that improved quality prints could be obtained by developing this stock at the normal time in the release developer. Therefore, with the processing characteristics of the print established, it was necessary to find the optimum constants for the negative, and the optimum print density. To facilitate this determination, use was made of the intermodulation test equipment recently developed by Electrical Research Products, Inc.² With the aid of this equipment

it is possible to determine readily the dynamic distortion of sound prints, using standard theater type reproducing equipment with the measuring apparatus. This tool is of considerable advantage in variable-density film research since no corrections must be applied. Static sensitometry provides the necessary laboratory controls but since the source of light and methods of exposure are not the same as in a recording machine, it does not give the true projection characteristics of the film.

In order to determine the processing constants of the fine-grain negative which would be best adapted for fine-grain printing, static

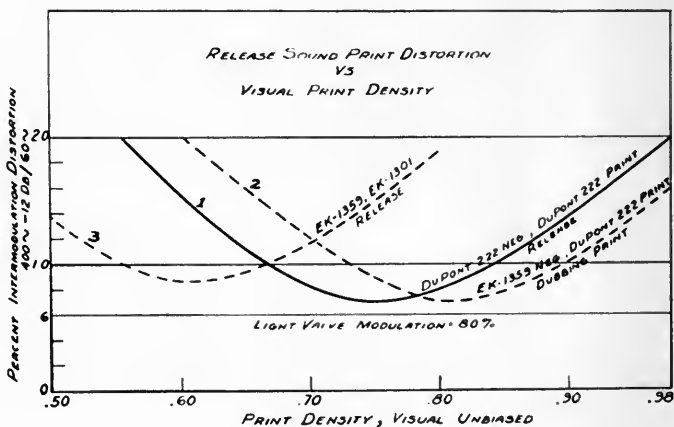

FIG. 8. Intermodulation distortion curves for (a) fine-grain release prints; (b) fine-grain dubbing prints; and (c) normal positive stock release prints.

sensitometric tests were first made of the new developer. 60-400 cycle intermodulation tests were then recorded at approximately 80 per cent modulation of the light-valve. This test was then repeated several times to provide a family of negatives covering the range of negative densities and gammas to be investigated. Prints of these families of negatives were made at various densities and measured on the distortion-analysis equipment, the results plotted, and the optimum operating points determined. This test serves independently to define a satisfactory negative exposure, negative control gamma, and positive print density, the print gamma being fixed by the positive developer.

Tests made in the same manner also disclosed that dubbing prints of materially improved quality and lower surface noise could be made on 222 stock using the normal low gamma 1359 negative.

In Fig. 8 the average values of intermodulation distortion as a function of visual unbiased print density are shown for the combinations of stocks currently used. The processing constants for the negative are optimum in each case.

(1) *Fine-Grain Release*.—Dupont 222 negative, air-cooled H3X arc recorder exposure, visual negative density 0.38, control gamma 0.27, special developer; Dupont 222 Hg arc print, normal positive developer. This improved combination is also applicable to original recording, and if made in this manner the original sound negative could be inter-cut with dubbed release negative.

(2) *Fine-Grain Dubbing Prints*.—EK-1359 negative, tungsten lamp exposure, visual negative density 0.55, control gamma 0.35, normal sound negative developer. Dupont 222 Hg arc print, normal positive developer.

(3) *Positive Type Emulsion Negative and Prints*.—This combination represents the former normal operation with the coarser-grained film stocks. EK-1359 negative handled in the same manner as in (2); EK-1301 tungsten print, normal positive developer.

The optimum values of intermodulation distortion of 7 to 8½ per cent indicated in Fig. 8 correspond to single low-frequency total harmonic distortions of approximately 1.8 to 2.2 per cent.²

Noise.—The signal-to-noise improvement was quite marked when fine-grain stocks were used. Table I shows the order of magnitude of the reduction in film noise which has been obtained.

TABLE I

Signal-to-Noise Ratios Referred to Positive Type Emulsions

Negative	D-222	EK-1359	EK-1359
Print	D-222	D-222	EK-1301
Use	Release or Original	Dubbing Prints	Release or Original
Relative Noise	-6 to -8 db	-3 to -4 db	0 db Reference

These determinations were made by aural comparison of unmodulated sections of the various types of tracks. However, it should be pointed out that for many types of recorded material, the reduction of modulated noise effects appears to be still greater. The lower noise level removes a veil which formerly masked many sounds, increasing the clarity and definition of the recorded signal. As these

improved stocks come into more general use, greater precautions will have to be taken to reduce extraneous stage noises, particularly during quiet, intimate scenes.

The greater volume range available increases the mixing latitude available to the original and re-recording mixers, thereby reducing the variations in background noise in the release product. At the same time a reduction in recording levels may be possible to reduce the number of recorded overloaded peaks. Experience has indicated that only a small fraction of all speech peaks are in the top 6 db of the volume range; therefore, since the present recording level has been set by limitations of film background noise on the one hand, and modulator overload on the other, the reduction of film background noise will permit the recording at a lower level of a cleaner track with no increase in noise in the final product.

The use of fine-grain films as negative or as print also effects a small improvement in the high-frequency response. The probable future use of ultraviolet printing of fine-grain stocks still further improves the high-frequency response, at the same time minimizing halation effects which are still present to some extent with the present technic of printing with unfiltered mercury arc light.

Conclusions.—The commercial application of fine-grain film stocks for release sound and picture printing, for release sound negative, and for dubbing prints has effected material improvement in picture detail and sound quality. The volume range has been considerably increased and the disturbing effects of modulated film noise reduced.

REFERENCES

¹ FRAYNE, J. G.: "Report on the Adaptation of Fine-Grain Films to Variable-Density Sound Technics," this issue of the JOURNAL, p. 3.

² FRAYNE, J. G., AND SCOVILLE, R. R.: "Analysis and Measurement of Distortion in Variable-Density Records," *J. Soc. Mot. Pict. Eng.*, XXXII (June, 1939), p. 648.

DISCUSSION

MR. FRIEDL: There was definitely a yellow tone in the picture shown on fine-grain stock. Of course, that is nothing new. We are all acquainted with those characteristics of fine-grain films, and we want to make sure in improving the sound that we do not work to the detriment of the white-colored screen image that everybody is working for. We must not fall back to low-intensity lamp days in trying to achieve perfection in sound. Motion pictures are a combination of picture and sound and we want to develop both together.

MR. GRIFFIN: The difference in color in these two presentations of this same scene were so marked that I had hoped there would be quite some discussion with regard to it.

MR. CRABTREE: It would be interesting to know which they prefer. Do they prefer the blue-black or the warm tone? (Ed.: A show of hands indicated approximately a 50-50 preference for the two tones.)

MR. SHULTZ: The projection equipment used here might be low-intensity.

MR. GRIFFIN: It so happens that it is.

MR. SHULTZ: Would not that tend to produce a yellowish appearance?

MR. GRIFFIN: We did notice, notwithstanding that, that one of the prints was distinctly yellow. Due to the small size of the picture, notwithstanding the type of arc used here, we are getting high illumination on this screen. If the screen were much larger, the difference would be more pronounced.

MR. KELLOGG: There is a chance for a little confusion in comparing the brownish effect that may result from the print with that related to the type of light-source. One tends to alter the color of the highlights, and the other affects the tones of the shadows.

MR. GRIFFIN: That is true, but it must be remembered that both prints were projected with the same light-source, and there was considerable difference in color.

MR. DAILY:* One complete feature-length picture has already been printed on this type of fine-grain stock and has been reviewed in a number of theaters and review rooms having high- and low-intensity arcs. The soft ivory tint noted in the picture has caused favorable comment because of reduced eye-strain and the increase in resolution which is obtained. The reduced image boiling on the screen makes the front seats in the theater much more usable from an audience standpoint. As mentioned by Mr. Kellogg, it is true that the color characteristics of all films are a combination of the characteristics of the type of film stock used and the type of projection light-source. Fine-grain films, as well as normal positives, benefit by the use of high-intensity arcs, and it is hoped that their use will rapidly become more general.

* Communicated.

PHOTOGRAPHIC DUPING OF VARIABLE-AREA SOUND*

F. W. ROBERTS AND E. TAENZER**

Summary.—Release print laboratories require a method of quickly making photographic duplicate negatives to replace damaged original negative sections.

The paper shows the development of a method of making dupes which have the same optimal print densities as the original negatives. A selection of film stocks is first made using the ratio of transmission between black area and fogs as a "yardstick." Processing data are shown in a family of curves, and the "best operating point" for the entire process has been determined. Fog considerations have been carried throughout the process.

An outline of commercial practice is given together with the necessary routine tests.

In release print laboratories, it is necessary to have some method of quickly making duplicate sound negatives to replace damaged original negative sections. At present, re-recording and photographic duping are the two methods of making duplicates in use. In the re-recording process, a carefully preserved release print or master sound print from the original negative is run in a film phonograph and the sound re-recorded with a standard variable-area or variable-density recording machine. However, the making of duplicate negatives, or dupes, by this method is not practical unless the laboratory is connected with a studio where recording apparatus and trained personnel are available. It would be far too costly for a laboratory to maintain recording equipment for the sole purpose of making duplicate negatives.

Photographic dupes have probably been in use as long as re-recording dupes, but the technic in general use and the resulting sound quality did not exactly suit our needs. It was decided, therefore, to develop a process of making variable-area dupes using the cross-modulation test method of determining best processing conditions. The following criteria were set for the process.

The quality of the sound from the dupe negative had to be high,

* Presented at the 1939 Fall Meeting at New York, N. Y.; received September 19, 1939.

** Ace Film Laboratories, Inc., Brooklyn, N. Y.

so that a trained observer, when listening to a print, would have difficulty in telling which section had been printed from a dupe.

All developing had to be done in the regular release print positive bath, at standard developing time. This requirement was set to save time, for inasmuch as the regular positive bath is in constant use no special machinery need be started to develop a dupe. Then, if dupes develop for the same time as standard prints, they may be spliced to the end of a release reel with a further saving of time and with no disruption of the regular work.

The dupe negative had to have the same optimal print density as the original negative, and the same fog in the clear areas, in order that the inserted dupe negative might be printed on the same printer light as the original negative. In other words, the dupe should call for the same printer light as the original. This criterion was set because the printing machines in use had no method of changing the printing light within a reel.

From the above it is seen that a "one to one" process was required. That is, we wanted a method of making a new negative which would have all the characteristics of the original negative from which it was to be made; it had to have the same fog and degree of image spread as the original negative, hence the term "one to one."

In general, the dupe process was to follow standard procedure, in that a master or dupe positive was to be struck off from the negative before any release prints had been made. This was to be stored for use in the making of dupe negatives when the need arose. The printing of the master sound from the original negative, and the printing of the dupe negative from the master sound print was to be done on a non-slip contact printer.

In order to satisfy the criterion of low fog or low density in the clear portion of variable-area dupe negative sound-track and yet have the dark area sufficiently black, it is necessary to maintain a fairly high contrast in every step of the process. However, the concept of high contrast or high sensitometric gamma is not enough. Gamma is the slope of a density-log exposure curve which in itself tells little of the ratio of transmission between the blacks and the clear areas on variable-area sound; and in printing it is this transmission ratio that is important. Prints are made through the clear areas and the blacks act as masks.

An approach to this angle of the problem was made through the transmission ratio chart of Fig. 1. These curves, each of which

represents a density of variable-area sound, were calculated from the following formula:

$$\frac{\text{Transmission Black}}{\text{Transmission Clear}} = \frac{\text{Log}^{-1} \text{Density Clear}}{\text{Log}^{-1} \text{Density Black}}$$

This family of curves shows the necessity for low fogs and high densities. High densities require a film stock with a high gamma,

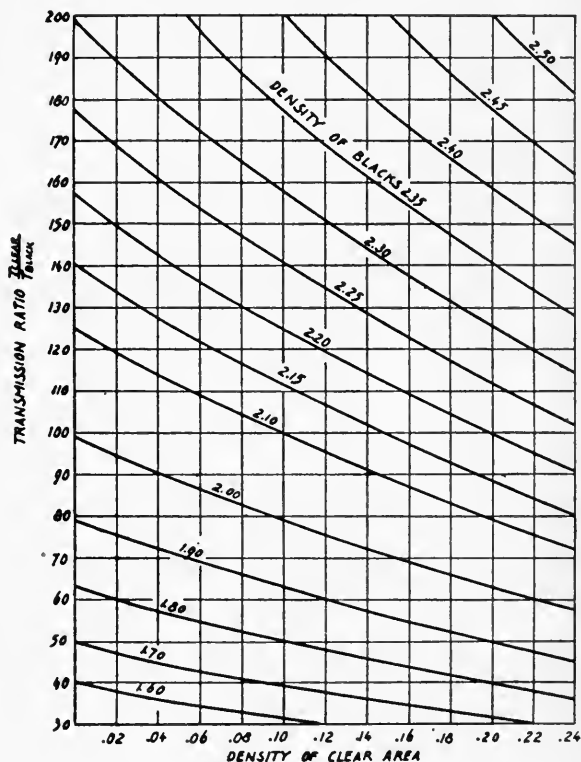

FIG. 1. Transmission ratio chart.

and low fogs result from a combination of high gamma and short toe characteristics. Therefore, in order to study these two factors, sensitometric curves of several film stocks were made, three of which are shown in Fig. 2. The stocks shown are all of Eastman manufacture and are respectively 1363 high-contrast positive, 1301 regular release print positive, 1365 fine-grain duplicating positive. The tests shown were exposed and developed as follows:

1363 and 1301—exposure with ultraviolet light on *I1b* Eastman Sensitometer, developed $3\frac{1}{2}$ minutes in a positive bath.

1365 —exposure with white light on *I1b* Eastman Sensitometer, developed $7\frac{1}{2}$ minutes in a borax negative bath.

This particular developing time for 1365 stock is that which gives best picture quality at our laboratory, and the curve was made in order to determine whether master positive sounds could be satis-

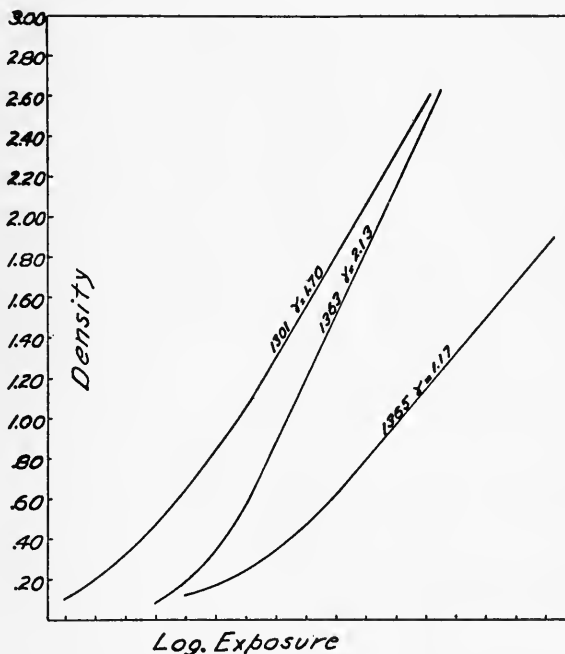

FIG. 2. Sensitometric curves of film stocks.

factorily printed on the same film with the master positive picture. The curve shows that it is rather difficult to secure high densities on this stock and that the toe is rather long. These two disadvantages, coupled with the fact that present non-slip contact printers tend to scratch the picture area of a negative, made it advisable to use a separate film with a high contrast-ratio for the master positive sound.

To test these two stocks, 1301 and 1363, the transmission ratio curves of Fig. 3 were made. Short prints, each a few feet in length, were made on an ultraviolet non-slip printer at several densities from

an original negative whose density was 2.12 and fog 0.05. It will be seen that the transmission ratio rises much faster than the fog. In the past, it has been somewhat customary to hold the black densities down to avoid excessive fog in a dupe positive, but it is now seen that the high densities give high transmission ratios in spite of rising fogs; and high fogs are no disadvantage in a master positive. A fog merely means that more light must be used to print the dupe negative. There seems to be little choice between the two films.

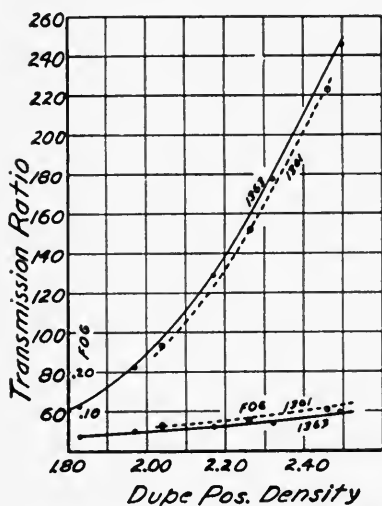

FIG. 3. Transmission ratio chart of 1301 and 1363 stocks as a function of fog.

picked after a study of Fig. 3 showed that the transmission ratio rose even with increasing fog. From these five dupe positive cross-modulation tests, 19 dupe negatives were printed ranging from approximately 1.40 to 2.35. Seven prints were then made from each of the 19 dupe negative cross-modulation tests, in order to determine the cross-modulation print optimum of each dupe negative. Seven points are about the minimum number which will give a clearly defined cross-modulation optimum. This step resulted in 19 times 7, or 133 prints, each 15 feet long. These were reproduced through a 400-cycle band-pass filter and the point of minimum 400-cycle output determined for each of the 19 print groups.

Fig. 5 shows two typical cross-modulation curves, one representing a print from an original negative, and the other, a print from a

It was decided to use 1363 as a master or dupe positive because it was felt that its high contrast would give a sharp boundary between clear and dark areas of track; and it was further decided to attempt to use 1301 as a dupe negative. Fig. 4 shows a cross-modulation survey of a duping process using these two stocks. To make this family of curves, the procedure was as follows. Five master positive prints, each about 15 feet in length, were made from an original negative cross-modulation test (9000 cycles modulated with 400 cycles). A range of densities from approximately 2.0 to 2.5 was

dupe negative. The ordinates are the number of decibels below a reference frequency of 400 cycles, the amplitude of which was the same as that of the 400-cycle frequency which modulated the 9000-cycle note in the recording of the original cross-modulation negative. The optimal points are those print densities where the curves have minima. Twenty such curves were made including the original, but only two are shown because of lack of space.

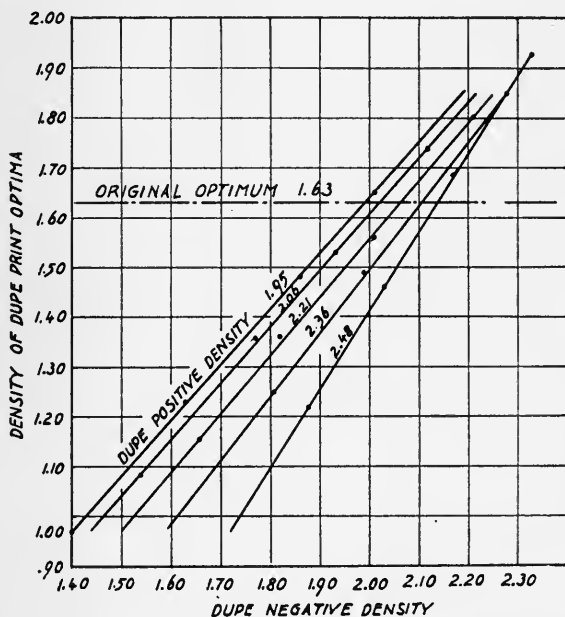

FIG. 4. Family of curves showing processing optima for a duping process using 1363 as a master positive and 1301 as a duplicate negative.

Fig. 4 shows the result of all the cross-modulation tests plotted in the form of a family of curves, a family being necessary because we wanted to represent three variables, namely: density of the master or dupe positive, density of the duplicate negative, and optimal print density. Each curve shows a group of negative densities and their resulting optimal print densities—all of which were made from one dupe positive density. There are five such curves representing the original five master dupe densities.

One of the original criteria was the aim to have the dupe negative

optimal print density the same as that of the original negative whose optimum of 1.63 is shown in Fig. 5. This value of 1.63 is shown in Fig. 4 as a dotted line, and the above consideration of identical optima is satisfied for any points of intersection with the family of curves. We, thereby, find five combinations of dupe negative and

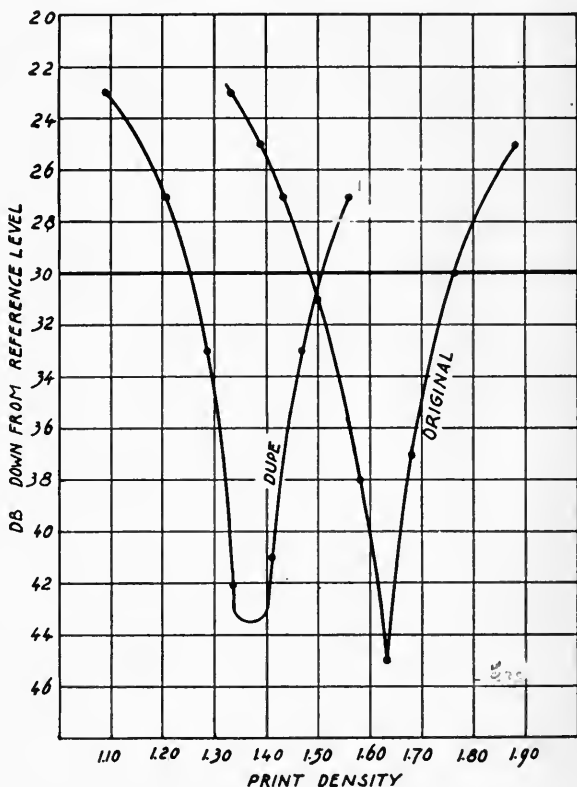

FIG. 5. Two typical cross-modulation print curves showing optima, and 30-db cancellation density range.

master positive densities which yield print optima identical with the original. These points are plotted in Fig. 6 which shows, for instance, that when the dupe positive is printed to a density of 2.20, the dupe negative should be 2.06.

Any combination on the curve of Fig. 6 will fulfill the criterion of identical dupe print and original print optima, but it was felt that one particular combination, out of all those shown in Fig. 6, probably

gave the best results; or, perhaps our family of curves was not sufficiently extensive to have hit the best possible operating conditions. So, in order to determine the best possible combination of master

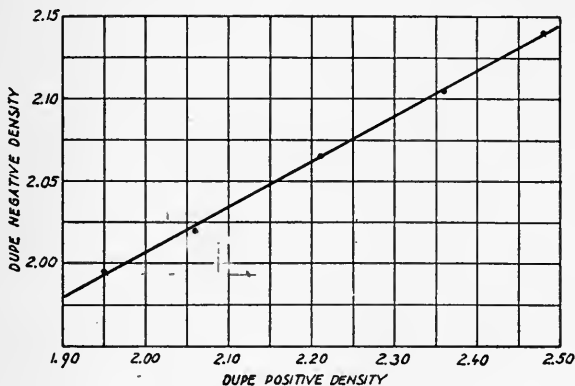

FIG. 6. Combinations of dupe positive and dupe negative which give the same print optima as the original negative.

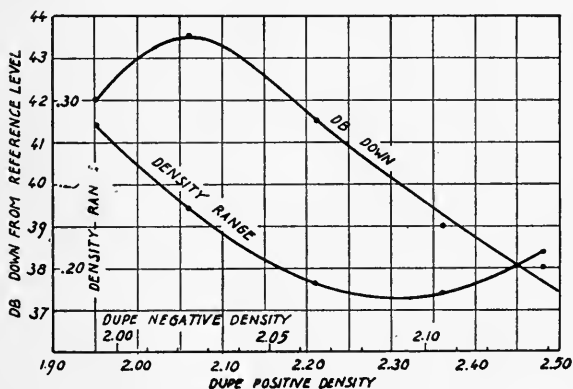

FIG. 7. Cross-modulation level as a function of combinations of dupe negative and dupe positive densities.

positive and dupe negative densities, it was decided to use as a factor of merit the number of decibels which the dupe print optima were below the reference level. Fig. 5 shows that this figure for one particular optimum is $-43\frac{1}{2}$ db. Fig. 5 also indicates the 30-db can-

cellation points which are the print densities at which the 400-cycle cross-modulation output rises to the level of 30-db below the reference frequency. It is generally accepted that any print whose cross-modulation level lies below 30 db is satisfactory, so the width

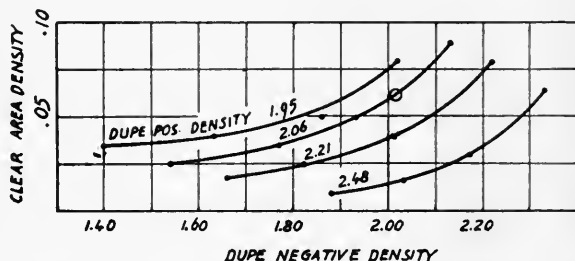

FIG. 8. Fog curve of dupe negative as a function of dupe positive and dupe negative density.

of the curve in the parameter of density measured between the intersection points with the 30-db line is an operating range for the print. The greater the width the greater the print density tolerance, so this width which we have called "density range" is also a factor of merit for the process.

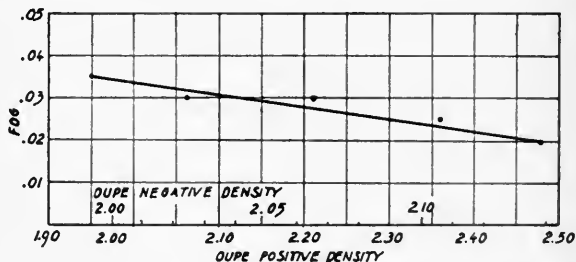

FIG. 9. Fog in final print as a function of combinations of dupe positive and dupe negative densities.

The factors of merit of "db down" and "density range" are known for all the 19 points of Fig. 4. It is an easy matter to interpolate between these points and find the values of the factors of merit for every point of Fig. 6. These two factors of merit are shown in Fig. 7 where the curve of Fig. 6 has been swung down to the X axis to form the double abscissa shown. It is very gratifying to find that

there is a "best operating point," and that at this point, the cross-modulation level is down $-43\frac{1}{2}$ db, or $1\frac{1}{2}$ db poorer than the cross-modulation level of the original print. The "density range" at this "best operating point" is 0.23 which compares very favorably with the density range of the original of 0.28.

Fig. 8 shows a family of curves which represent the fog or clear area densities of the dupe negative for all the points shown in Fig. 4.

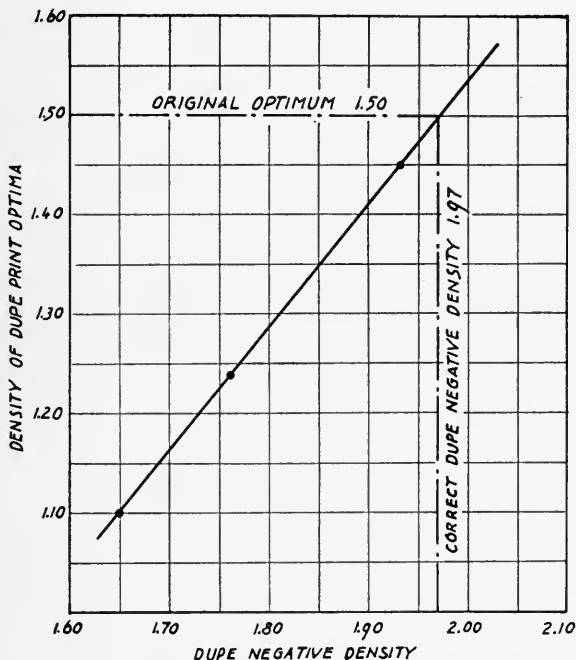

FIG. 10. Curve of print optima vs. dupe negative density. All negatives printed from a dupe positive density of 2.05.

Throughout this paper all densities are given excluding densities of base, unless otherwise specified. The point represented by the large circle is the "best operating point" determined from Fig. 7, and the fog of 0.06 at this point is very satisfactory when compared with the fog of 0.05 of the original negative.

Fig. 9 is a curve having the same abscissa as Fig. 7, but its ordinates are clear side densities or fogs in the final print. These fogs are low enough to be negligible over the entire range.

All these data, so far recorded, represent a treatment of one particular cross-modulation test negative taken from one reel of a feature picture. Now, it is obvious that it would be impossible to treat every reel of every feature in the above manner, but such complete treatment is not necessary, for the procedure developed above is a "one to one" process. That is, for all practical purposes, it duplicates the image-spread of the original negative. However, at no place in the process does the degree of image-spread of the original negative enter; so we feel that within reasonable limits the above-determined "best operating point" holds for any original negative, providing the printer characteristics and the processing constants for 1363 and 1301 stocks do not change. It was felt, nevertheless, that certain tests should be made for every feature, so the following procedure was evolved.

Master positives of every reel of a release, and the accompanying cross-modulation tests are first printed on 1363 stock to a density of 2.05. The reels of master positive are stored, but the cross-modulation test positives are detached and printed on 1301 stock to make dupe negatives. The test from 1A is printed at three negative densities and the tests from the remaining reels are printed to a density of about 2.00. Cross-modulation prints at several densities are then made from each of the dupe negative cross-modulation tests; and, from these prints the optimal print density for each dupe negative is determined. Reel 1A gives us a three-point slope curve, a typical example of which is shown in Fig. 10.

Theoretically, these dupe print optima should be the same as the optima of the prints from the original negative,* for the master positives and dupe negatives were made according to the technic set forth in this paper. But, experience has shown that changing processing conditions and new emulsion numbers, sometimes, cause a shift of dupe optima. The slope curve of Fig. 10 then may be used for making corrections.

The correct value of dupe negative density for reel 1A may be found directly from Fig. 10, as is shown, but the slope only is used for correcting the remaining reels. To use the slope, assume a hypothetical case where the original optimum of reel 2B was 1.55. We will further assume that the dupe negative density was 1.90 and that its optimum was found to be 1.45. Fig. 10 shows that an increase of 0.08

*These values are on file, having been found previously to determine the release print operating range.

in dupe negative density will raise the optimum 0.10. By raising the dupe negative then to 1.98, we will be assured of a negative which will match the original. These values of corrected dupe negative densities are kept on file for use during the printing of a release. When a negative is damaged, the correct dupe negative density is obtained from the files, and a section of dupe negative printed from the stored master positive. Immediately after development, the duplicate negative may be used to replace the damaged section with the assurance that it will take the same printer light as the remainder of the negative.

This process has been in use on all Warner, First National, and Vitaphone releases for the past four months and has given consistently good results.

In conclusion, we would like to point out that no claim is made that the process herein developed represents the ultimate in photographic sound duping, but we do feel that the method of treatment is new and useful in developing any duping process.

BIBLIOGRAPHY

R. C. A. Mfg. Co., Inc., RCA-Victor Division, "Instructions for Quality Control of Variable-Area Sound-Tracks," April 25, 1938.

BAKER, J. O., AND ROBINSON, D. H.: "Modulated High-Frequency as a Means of Determining Conditions for Optimal Processing," *J. Soc. Mot. Pict. Eng.*, **XXX** (Jan., 1938), p. 3.

BAKER, J. O.: "Recording Tests on Some Recent High-Resolution Experimental Emulsions," *J. Soc. Mot. Pict. Eng.*, **XXX** (Jan., 1938), p. 18.

BAKER, J. O.: "Processing of Ultraviolet Recording on Panchromatic Films," *J. Soc. Mot. Pict. Eng.*, **XXXI** (July, 1938), p. 28.

BLANEY, A. C., AND BEST, G. M.: "Latest Developments in Variable-Area Processing," *J. Soc. Mot. Pict. Eng.*, **XXXII** (March, 1939), p. 237.

A SOUND-TRACK CENTER-LINE MEASURING DEVICE*

F. W. ROBERTS AND H. R. COOK, JR.**

Summary.—Release print laboratories need some sort of device to check quickly sound-track center-line positions on release prints. No satisfactory device was available, so a measuring machine was developed that indicates track position directly on a dial indicator.

Since the advent of sound it has been necessary to measure the position of the sound-track on both positive and negative films, and for these measurements two classes of devices have been evolved. One group of instruments consists of standard microscopes to which film-holding devices and micrometer oculars or micrometer stages have been added. The other group of instruments consists of projection devices which project enlarged images of the sound-track area on calibrated screens.¹

Both these groups of instruments serve well the needs for which they were built. However, neither type is suitable for use in release print laboratories where a large number of sound-tracks must be checked rapidly by non-technical operators.

The projection type of device requires a darkened room, occupies quite an area, and requires some mental arithmetic to arrive at the center-line measurement. For the quick checking of one print in many reels, it also consumes too much time in threading.

The microscope types, while easy to thread, are too slow in operation. With them, the procedure is somewhat as follows: A reading of the micrometer screw that moves the film-holding mechanism is taken when the edge of the film is beneath the cross-hair of the microscope eyepiece. Readings are then taken with each of the two bias lines, in the case of bilateral variable-width recording, successively under the cross-hair. Two readings are thus obtained—one, the distance from the film edge to the inner bias line, which we will call A ;

* Presented at the 1939 Fall Meeting at New York, N. Y.; received October 5, 1939.

** Ace Film Laboratories, Inc., Brooklyn, N. Y.

the other, the distance to the bias line nearest the sprocket hole, which we call B . The center-line will then be

$$B + \frac{A - B}{2}$$

This bit of mental arithmetic is slow and fatiguing if continued all day.

Since no existing device fulfilled the needs of our laboratory, we set out to design a measuring device that would be quick in threading, occupy very little space, be portable, and require no calculation to arrive at the sound-track position.

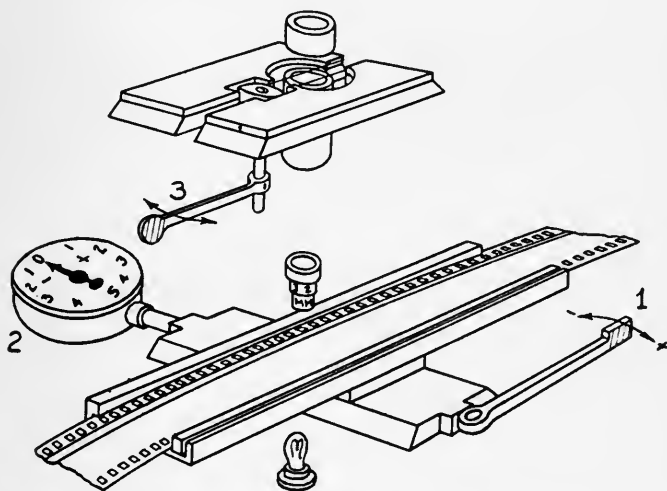

FIG. 1. Schematic arrangement of device.

Fig. 1 is a diagram of the construction. Light from a small lamp shines through the film which is held by a spring parallel against the edge of a slightly curved gate which slides in Vee slides in a direction perpendicular to the film direction. Motion is imparted by the lever 1, and the position of the film-gate is indicated by the one-tenthousandth dial indicator 2. Directly above the film-gate, standard microscope optics have been mounted, which consist of a 32-mm objective lens and a 10-power Huygen's eyepiece. However, the usual cross-hair has been replaced with two parallel hair devices which slide in Vee slides. The lever 3 causes the hairs to move always in a direction parallel to each other, and equidistant from the optical

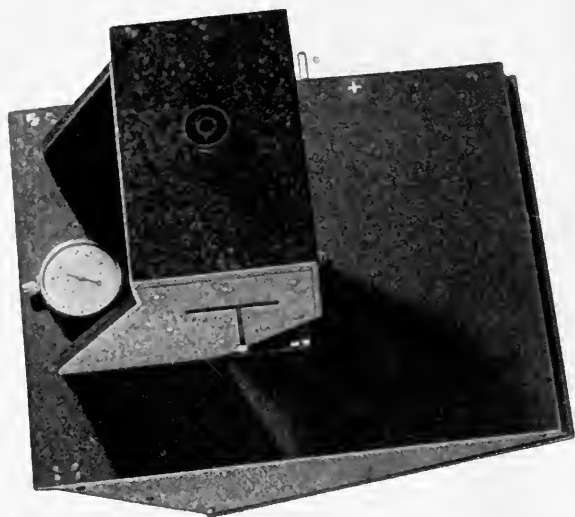

FIG. 3. View showing lever (3, Fig. 1), eye-piece, and dial indicator.

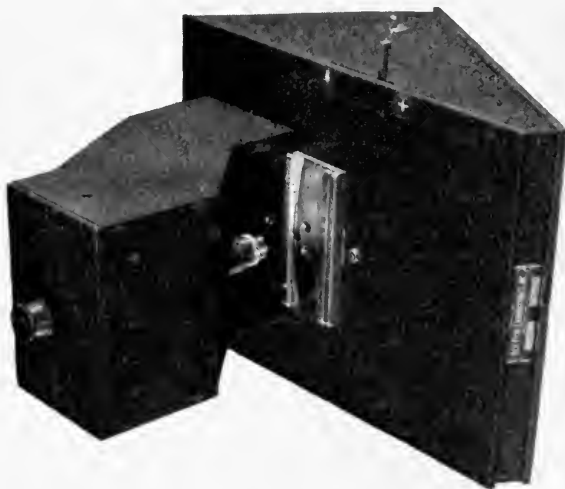

FIG. 2. View showing lever (4, Fig. 1), film-gate, and eyepiece.

center of the instrument. Fig. 2 is a general view of the completed device, which shows the film-holding device, the light switch, and



FIG. 4. General side view.

one of the operating levers. Fig. 3 shows both operating levers, the eyepiece, and the center-line indicating dial. Fig. 4 is a general side view.

The operation is as follows: Film is placed in the gate. Levers 1 and 3 are moved until the two parallel hairs are each over a bias line, or over corresponding peaks, where there is modulation (Fig. 5). The center-line is then read on the dial indicator which has been calibrated so that *O* on the dial corresponds to a track center-line position of 243 mils from film edge. Two markings, a plus and a minus, have been placed above the operating lever 1. They are useful in telling the sign of the deviation when the dial indicator has revolved more than one-half revolution in either direction.



FIG. 5. View through eyepiece showing variable-area track and parallel hairs.

Film may be inserted and the center-line read in ten seconds, and the reading may be duplicated to two ten-thousandths of an inch by different observers.

In a release print laboratory we have no need for figures of percentage modulation, but it is entirely possible to calibrate lever 2 directly in percentage modulation, for the separation of the hairs is proportional to the amplitude.

Two of these instruments have been in use for more than a year and are found to be very useful and accurate. They have needed no re-calibration, for the accuracy is dependent only upon the dial indicator.

REFERENCE

¹ BEST, GERALD M.: "A Sound-Track Projection Microscope," *J. Soc. Mot. Pict. Eng.*, XXXIII (Aug., 1939), p. 198.

DISCUSSION

MR. PALMER: When you find that the center-line of the sound-track is not in the right place, what do you do about it?

MR. ROBERTS: We adjust our printers. By printer adjustment we can even compensate for negatives which have misplaced sound-tracks. This device is used to control printing machines. A certain percentage of the output from each printing machine is measured, and a chart kept for each machine. When we observe a drift as indicated by the chart, we adjust the printer.

The machine has been calibrated so that the zero point on the dial represents a center-line of 243 mils from the film edge. The operating lever has been marked with plus and minus, so that the operator will know the sign of the deviation when the dial revolves more than half a revolution.

DR. CARVER: Have you made any survey of the release prints to find what the general deviation is, as the theater man sees it?

MR. ROBERTS: I am not acquainted with products other than the Warner releases. We keep our prints within ± 3 mils' maximum deviation. The average is probably better than that.

Perhaps such a device would be useful in checking a large number of prints in an exchange, where, for a very rapid survey, it could be placed between rewinders.

STARTING CHARACTERISTICS OF SPEECH SOUNDS*

R. O. DREW AND E. W. KELLOGG**

Summary.—In view of its bearing on the design of ground-noise-reduction systems, a study was undertaken to determine how sudden or rapid are the increases in amplitude of the speech sounds that must be recorded in dialog. A large number of oscillograms were taken, a number of which are reproduced herewith.

The most important observation is that the human voice can start several of the vowel sounds in such a way that the first wave is from 40 to 80 per cent of the final amplitude, or, in other words, with a suddenness comparable to that of keying in an oscillator. However, this is rare, being for all practical purposes confined to a few of the more open vowel sounds, when not preceded by any consonant, and true only of certain individuals, depending on the manner of releasing the breath. Progressive build-up at rates which would carry the modulation from zero to 100 per cent in 0.05 second are frequent, while the great majority of syllables start more gradually than this.

There are several types of apparatus which operate in response to the presence or the amplitude of an audio-frequency voltage or current. Telephone companies employ such devices for switching purposes, but the applications which are of principal interest to motion picture engineers are compressors and ground-noise-reduction systems. The current for operating these devices is derived from rectified audio-frequency currents, and it is necessary, in order to prevent disturbing noises, that the rectified current be filtered, which is just another way of saying that the current is not permitted to make sudden jumps in value. Thus there is a limit to how closely the operating current can follow fluctuations in amplitude of the audio-frequency current. Failure of the current to fall quickly when there is a decrease in amplitude does not in general have any objectionable results, but failure to rise promptly when the audio-frequency amplitude increases causes distortion. In the case of a compressor, the initial waves are not cut down in amplitude as much as those immediately following, and an unnatural effect may result. If the compressor is depended upon to prevent overloading, it may

* Presented at the 1939 Fall Meeting at New York; received October 29, 1939.

** RCA Manufacturing Co., Camden, N. J.

fail to act quickly enough, with a resulting quality loss, or a wax record may be overcut and ruined. In the case of ground-noise-reduction systems as applied to photographic sound recording, too slow opening of the masking device causes clipping of the tops of the initial waves. The industry has tolerated these faults, and efforts have been made to minimize them, but they are still with us.

Obviously if the audio waves increase in amplitude only gradually, the small time-lag in response of the control current will have negligible effect. In other words, it will, throughout the crescendo, have very nearly the value that it should have in view of the amplitude of the audio waves at that instant. The more rapid the increase in audio amplitude, the farther will the control current fall below the desired value. This is illustrated in Fig. 1.

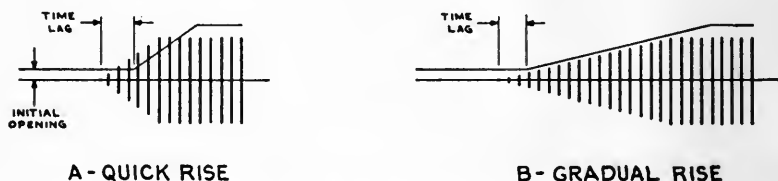

FIG. 1. Aggravation of wave-top clipping when rise is rapid.

Ground-noise-reduction systems are designed to provide a margin of excess opening, in the form of an initial opening, which is maintained even when the audio-frequency modulation is zero, and, in addition, a margin of excess gain is provided which in the steady state causes the masking to clear the tops of the waves by a generous percentage. It is these margins which protect the system from continual overloading or clipping at almost every beginning of a word or syllable, but, on the other hand, large margins defeat the purpose of the ground-noise-reduction system.

A number of expedients have been proposed for speeding up the action of ground-noise-reduction systems. All these involve more or less complication, and no matter how fast the system may be made (within practical limits) there is always a possible rate of build-up of the audio-frequency waves such that the margin will be insufficient to prevent clipping. It is therefore pertinent to ask, "What is the steepest rate of build-up that will normally be encountered in sound recording?" and, second, "How often will these very rapid build-ups

occur?" The studies of which this paper is a report, were undertaken for the purpose of answering the first question and extended in the hope of throwing some light on the second.

It is well known that when there is considerable reverberation, maximum amplitude is not reached until after an appreciable interval after the start of the original sound. Since music is recorded in fairly "live" enclosures, it may be assumed that rates of build-up rapid enough to cause difficulties will not often be encountered in music recording. In "sound effects" almost anything might be expected, and it hardly seems reasonable to attempt to anticipate what demands may be imposed on recording systems. It is probable that, at least in the case of the louder sounds, more or less reverberation may in general be looked for. The major part of sound-on-film recordings is talk, and is recorded in fairly dead sets. Thus the most important part of the problem is concerned with how speech sounds start. An obvious approach would be to examine a large amount of recorded dialog. Such a study, if carried out on an adequate scale, affords the best answer to the question of frequency of occurrence of very sudden beginnings. Of more scientific and general interest, however, is a study in which all the sounds examined are identified, and several voices are used for each sound.

The method chosen consisted in producing a trace of the wave-shape on a cathode-ray oscillograph and photographing the screen with a film-pack camera. Three oscillograms could be photographed on each film. Mr. S. Read, Jr., proposed and worked out for us an arrangement for controlling the sweep of the cathode-ray beam which turned out to be very useful. When the circuit is set for an oscillogram, the beam is just off the screen on the left. Pressing a key releases the sweep and the spot travels at a very slow rate, of the order of an inch in three seconds. An extremely small audio-frequency disturbance serves to trip a thyatron which suddenly changes the bias on the grid of a pentode through which a condenser is discharged and the sweep then proceeds at a speed of 10 inches per second. The speaker watches the screen and upon seeing the spot crawl out onto the screen, makes the desired sound, which sound is recorded at the full sweep velocity. No waves can be lost by this method, although conceivably, if the release were not quick enough, the first waves might be compressed on the time-scale. The release time is of the order of a few microseconds and the oscillograms do not show any evidence of failure to record all of the sounds. The

slow travel of a light-spot causes the first part of the trace to appear very heavy, due to spread of exposure in the film. In several of the sounds, a period of very low modulation (too small to appear on the oscillogram) is indicated by the sudden narrowing of the horizontal trace. The beam became slightly defocused toward the edge of the

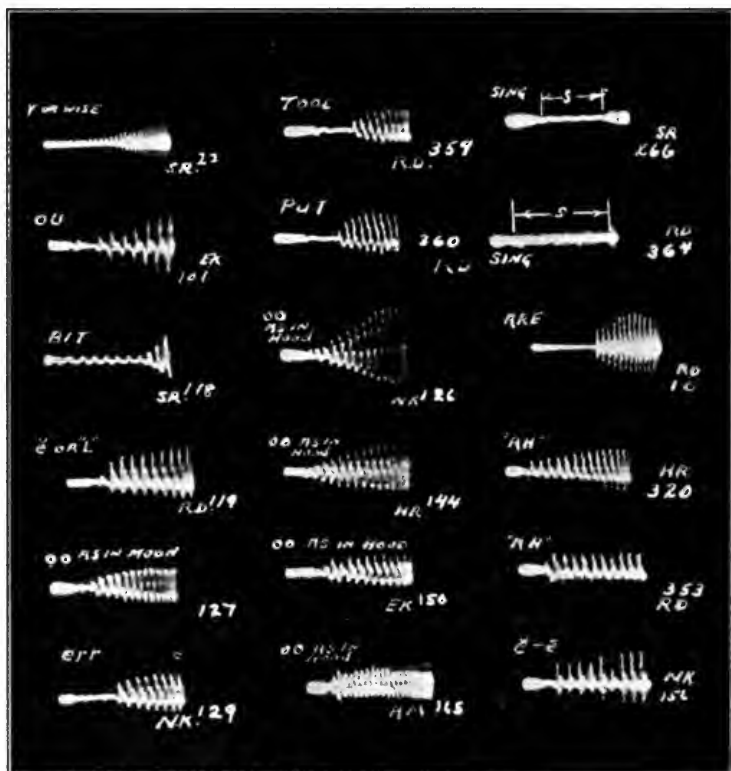

FIG. 2. Examples of oscillograms.

screen so that detail is lost here in the oscillograms, but this did not defeat the purpose of showing the starting characteristics. We are concerned primarily with the envelope of the wave, so no effort was made to correct the defocusing. Consideration was given at first to showing only the envelope rather than a true oscillogram, but this would fail to show some factors which might turn out to be of concern. For example, if a rapidly rising envelope is produced by com-

paratively few waves, the action on the rectifier will be materially different from the case in which the envelope widens at the same rate, but there are shorter intervals between the peaks. It will be noticed, for example, that the oscillograms by *E. K.* show a remarkably wide spacing between sharp peaks, although the voice fundamental in this case was not much lower than that of the others. This was at

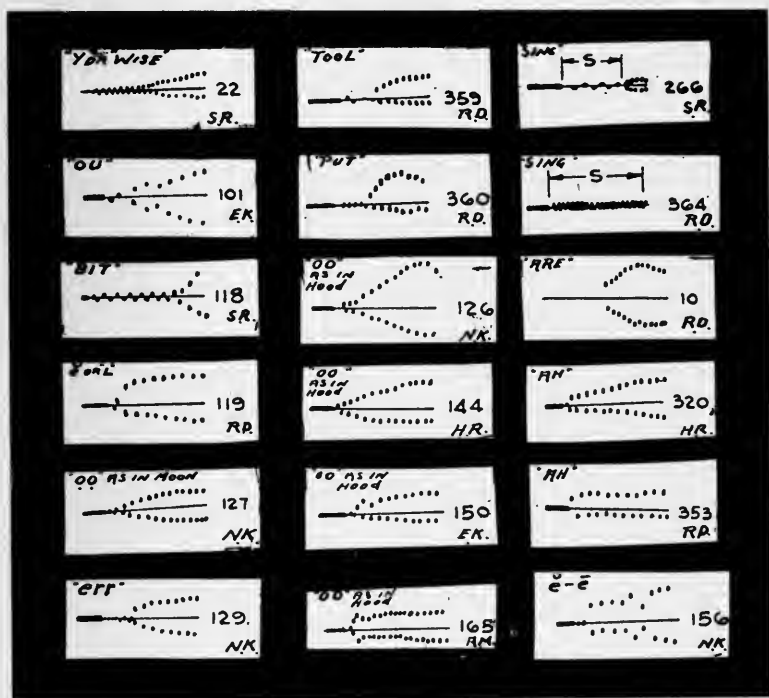

FIG. 2A. Tracings of oscillograms of Fig. 2.

first attributed to some error in the speed of the sweep, but further tests showed the same characteristic. If there was any departure from the correct speed during any of the tests, it was small enough to be of no significance.

Fig. 2 shows a number of the oscillograms. Those who have tried photographing cathode-ray oscillograms will understand the difficulty of getting a picture which is entirely satisfactory for copying by a halftone process. Although our oscillograms were entirely legible,

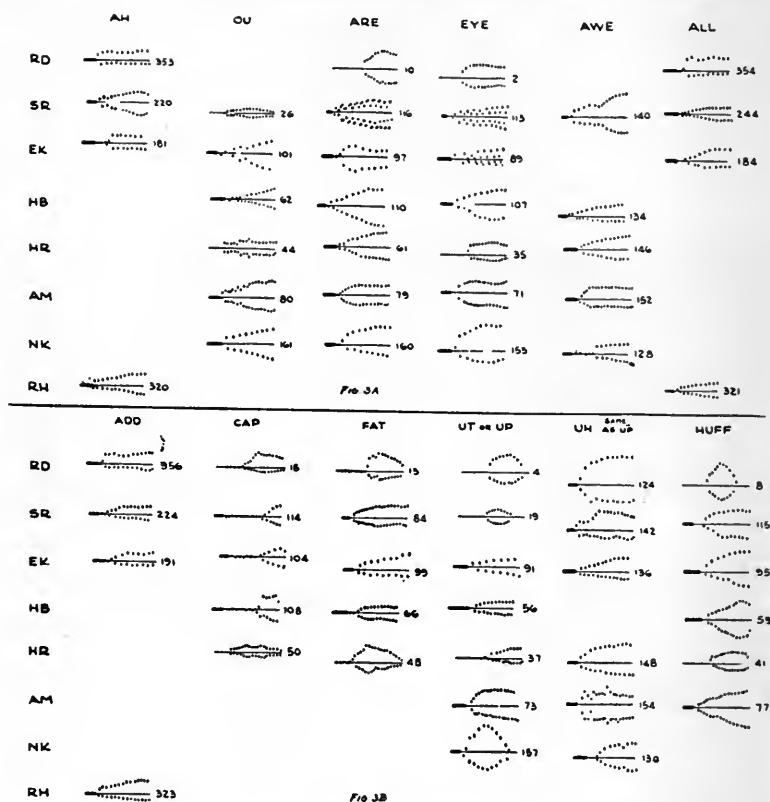

FIG. 3. Tracings of oscillograms of speech sounds.

we feared that many of them would not make satisfactory engravings. Some of the peaks, for example, were so faint that they might be lost. We decided that a tracing, with a dot at each peak, would show about everything that had an important bearing on the present study. Therefore we had a set of such tracings made, and are depending on these to show the growth characteristics of the various sounds. Fig. 2A shows the tracing corresponding to each of the oscillograms shown. In the tracings the end of the heavy line indicates where the circuit tripped and the spot moved at full velocity. Dots substantially along the axis before the main sound indicate the existence of a small preliminary modulation, as for example, a consonant. It is obviously impossible as well as unimportant for our

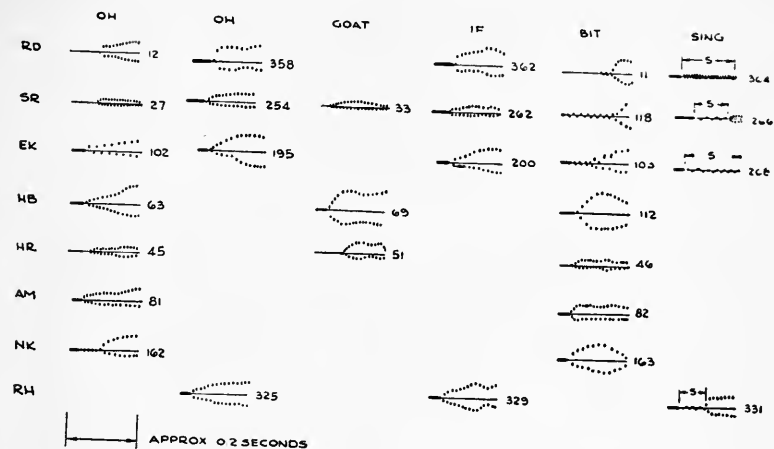
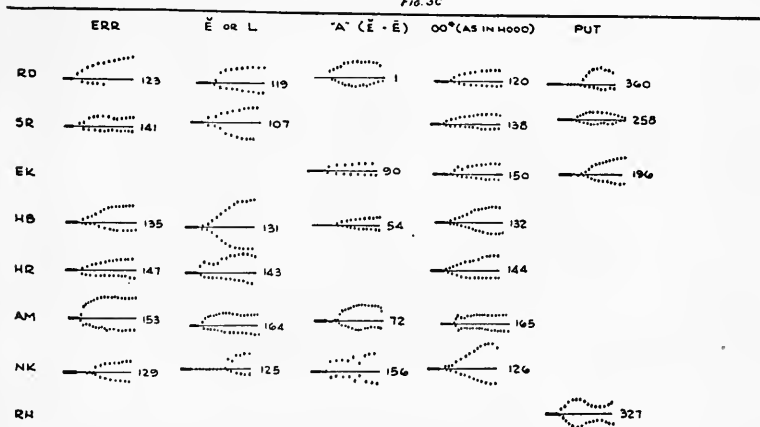

Fig. 3C



* ALMOST NEVER USED AT BEGINNING OF ENGLISH WORD.

Fig. 3D

FIG. 3 (Continued). Tracings of oscillograms of speech sounds.

purpose, to show the exact amplitude or wave peak positions in this low modulation. The entire set of tracings is shown in Fig. 3.

The speaker faced the ribbon microphone at a distance of about two feet, in a heavily damped room. Before making the oscillograms here shown, the effect of varying the distance from the speaker to the microphone was tried. No significant change was noted. Tests were made also with the microphone from three to four feet from the speaker and a reflecting surface about the same distance

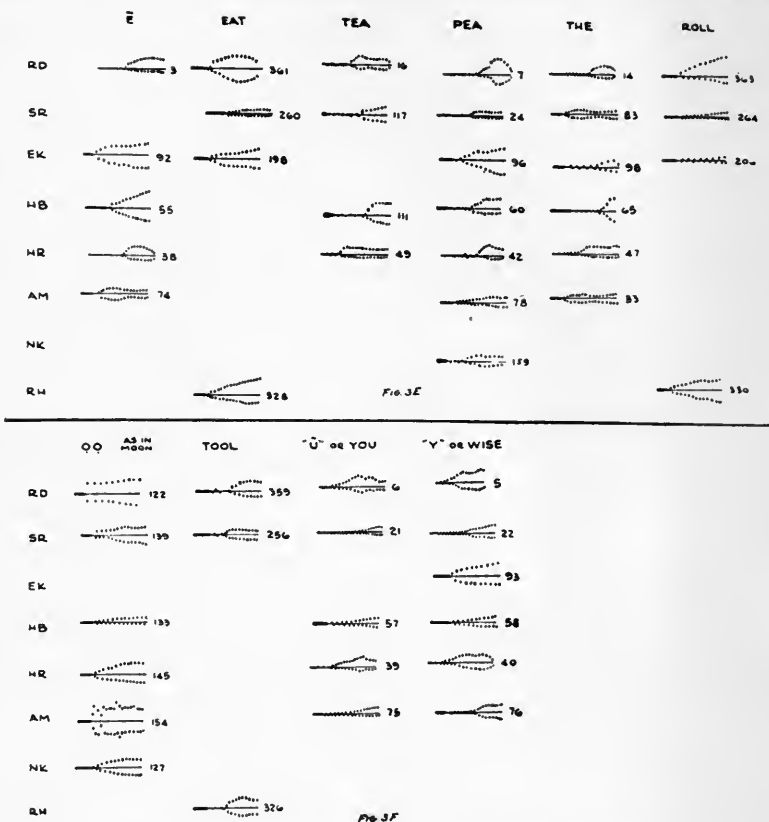

FIG. 3 (Continued). Tracings of oscillograms of speech sounds.

beyond the microphone. This was for the purpose of answering the question whether such echoes as come from the walls of a motion picture set would materially alter the story of how rapidly sounds start. It is assumed that the set would be so constructed that there would be a negligible amount of multiple reflection. The effect of the single echo produced as described above was, as might be anticipated, quite small and in no wise prevented the sounds from building up to a large fraction of their final amplitude, substantially as quickly as without the reflection.

As has already been indicated, there was doubt in the minds of the writers whether the human voice mechanism is capable of building up sounds so rapidly as to reach substantially full amplitude in

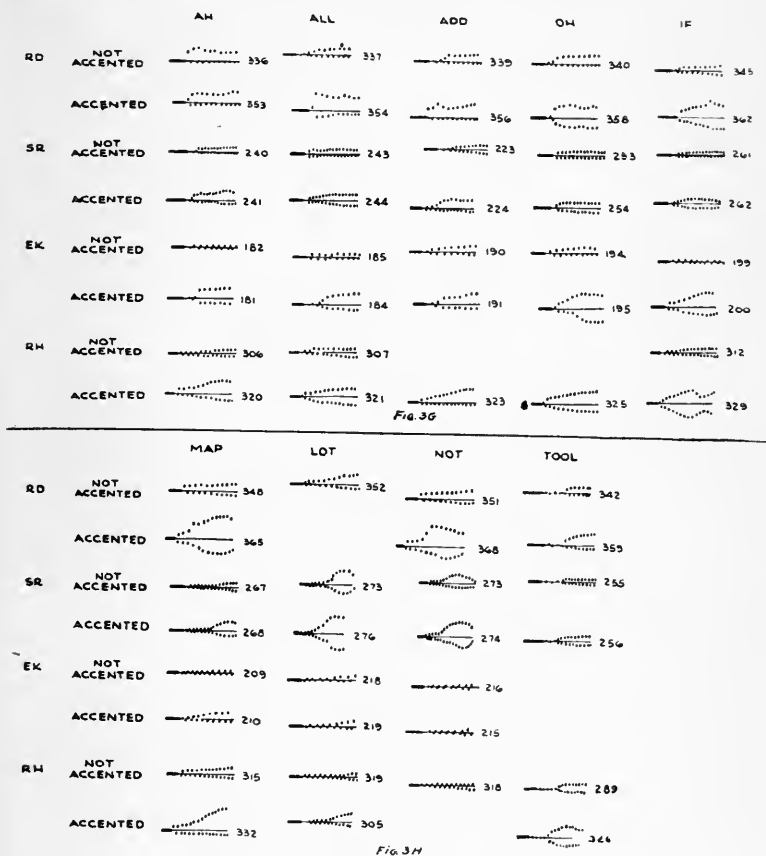

FIG. 3 (Continued). Tracings of oscillograms of speech sounds.

one or two cycles. Since a number of resonators are involved, it might be expected that the voice would have the characteristic which is usual in oscillators, namely, that a considerable number of cycles is required to reach full amplitude. This depends on the ratio of feedback to damping, and the writers had little knowledge of these factors. It did not take many tests to show that it is quite possible to reach practically full amplitude even on the first wave. Therefore cases will occur in which clipping of the first wave can not be avoided by a ground-noise system of any speed within the range of

practicable application for ground-noise reduction. Such clippings must thus be tolerated unless an anticipation system can be employed.

The next question is, how often will this very sudden burst of sound be encountered. We had hoped that our studies would give some indication on this point but soon discovered that this would be a statistical matter not readily subject to direct experiment. Therefore this phase of the problem must be deferred, and we confine ourselves to an examination of the relative tendency of various word sounds to produce these rapid crescendos and to study the nature of the increase in amplitude.

The oscillograms may be classified into:

- (1) Those which increase gradually from zero to substantially full amplitude.
- (2) Those which increase in the same continuous manner but more rapidly.
- (3) Those which jump suddenly to an appreciable fraction of maximum amplitude and thereafter rise slowly.
- (4) Those which follow the initial jump by a more rapid increase to full amplitude.
- (5) Those which show fifty per cent or more of the maximum amplitude on the first or perhaps the second wave, thus giving an envelope with a large shoulder.

There may also be, in combination with any of the sounds described above, a preliminary modulation of low amplitude, ordinarily the result of some consonant sounds preceding the vowel. This preliminary low-amplitude modulation is an important factor in design of ground-noise-reduction systems, in that it can be used to start the shutter opening, and this will materially reduce the likelihood of clipping the larger-amplitude waves.

Inspection of the oscillograms shows that the starting characteristic is far more dependent on the person talking than on the specific word sound. For example, *R. D.* produced shoulder-type starts in a very large fraction of the sounds, while *H. B.* produced only one. Neither are successive utterances of what is supposed to be the same vowel sound consistently the same in envelope nature when spoken by the same person.

The gain in the system is substantially constant throughout the series, so that the differences in final amplitude are almost entirely a question of how loud the person talked. If a person talked consistently, a fair comparison could be made between the amplitudes which are likely to appear in various vowel sounds. The larger amplitudes are produced only by the vowel sounds. Most conso-

nants are relatively very weak. The semi-vowels, or sustained consonant sounds: *l, m, n, z, j*, give considerably larger amplitudes than most other consonants, but are still far below the vowels. *R* is intermediate. On rare occasions *s* may produce large amplitudes, particularly if high frequencies are exaggerated for recordings, as is frequently done, but this is so unusual as to be of no practical importance for the main purpose of this study. An extensive study of the subject has been made by C. F. Sacia.¹ The figures in Table I on vowel sounds are taken from Dr. Sacia's paper.

TABLE I

Relative Power and Peak Factors in Vowels

Speech Sounds	Male Voices		Female Voices	
	Power	Peak Factor	Power	Peak Factor
ŌŌ (<i>Tool</i>)	27	2.6	41	2.8
OO (<i>Hood</i>)	33	4.0	40	3.1
Ō (<i>Oh</i>)	33	4.1	44	3.4
Awe	37	4.5	50	3.3
Up	29	4.6	38	3.9
Ah	50	4.2	48	3.6
Add	44	5.4	39	4.7
ě (<i>ever</i>)	26	5.6	31	3.8
A (<i>Aim</i>)	22	5.3	30	4.5
Ī (<i>It</i>)	25	4.1	32	3.8
ē (<i>eel</i>)	23	4.7	23	2.6

In Fig. 3 the vowel sounds have been arranged roughly in order of the successive mouth positions, from wide open to nearly closed. This is likewise substantially the order which they would take if arranged in order of decreasing tendency to produce large amplitude. Abrupt starts or "shoulder-type" envelopes are somewhat more common in the open vowels.

We had rather expected that preceding a vowel by one of the explosive consonants, *p, t, k*, would be especially likely to produce an abrupt start. This is not the case. It appears that the likelihood of large shoulders in sounds beginning with *p, c*, and *t* is about the same as for the corresponding vowel sounds when not preceded by any consonant. The most sudden attack seems to be produced by building up some air-pressure in the lungs, with the epiglottis closed, and releasing it suddenly, which has the effect of beginning the sound with something like a grunt. This is widely done in greater or less degree and is probably a characteristic of the individual. It can, of

modulation, but is conducive to a more gradual build-up in the vowel sound itself.

In some preliminary observations, it appeared that the amount of shoulder was little affected by whether the sound was accented or not, the main effect of accent being to cause the vowel to continue its crescendo to a higher final value. Oscillograms taken subsequently in which the same sound was spoken successively without and with accent did not altogether bear out this observation, the principal effect of accent being to raise the amplitude throughout the whole range, or, in other words, to magnify the envelope in the vertical direction. The accent comparisons are shown in Fig. 4.

One of the interesting things to be observed in these oscillograms is the consistency with which upward deflections exceed the downward deflections, whenever there is any difference. That this was not due to any distortion in the equipment is proved by simply turning the microphone 180 degrees. In Fig. 4 all the oscillograms (with the exception of Nos. 181 and 183) made with the microphone in the regular position are shown above, and just below each of these is an oscillogram made immediately afterward, with the microphone reversed. This characteristic of speech sounds was pointed out by S. Read, Jr., in connection with his discussion of the "Neon Volume Indicator"² and its applications, and has recently been discussed by J. L. Hathaway.³ It has further been observed by Mr. Read and other engineers in the RCA laboratories that if clipping does occur, it is less objectionable when it is the short peaks that are clipped than if the high peaks are clipped.

Both these facts are important factors in ground-noise-reduction systems. If the ground-noise-reduction system is designed to work on the negative half-waves, not only is less shutter movement (or its equivalent) needed to avoid clipping, but the damage to quality if clipping occurs is less serious than if the opposite polarity is used.

Such observations and generalizations as we have so far reported apply to both the pressure and rarification halves of the waves. In general the positive and negative envelopes are of about the same shape (as if the same curve were simply plotted to a different scale). When there is any difference in shape at all, it is almost without exception in the direction of slower build-up for the negative half-waves. A difference in shape which appears in a considerable number of cases is that the negative build-up is delayed with respect to the positive, as, for example, oscillograms Nos. 57, 39, 5, 22, of the \bar{U} and

Y sounds. When a sound of this type is produced, a ground-noise system so designed that it has to clear only the negative peaks, is given the benefit of a warning modulation of small amplitude, before the major increase begins.

REFERENCES

¹ SACIA, C. F.: "Speech Powers and Energy," *Bell Syst. Tech. J.*, 4 (April, 1925), p. 627.

² READ, S., JR.: "A Neon Type Volume Indicator," *J. Soc. Mot. Pict. Eng.*, XXVIII (June, 1937); p. 633.

³ HATHAWAY, J. L.: "Microphone Polarity and Overmodulation," *Electronics* (Oct., 1939), p. 28.

DISCUSSION

MR. OFFENHAUSER: What kind of microphone was used, and what was the distance from the microphone to the speakers?

MR. KELLOGG: The person sat about two feet from the microphone in a heavily damped room. We tried some tests with reflectors, but with no appreciable result. The effect of the reflector was not to produce anything approaching real reverberation.

MR. BERGER: What was the maximum relative change on the steepest curve found, between the point of where you could just about see the change and where it showed up as a rather large change?

MR. KELLOGG: We have only the oscillograms to go by on that. The preliminary vibrations were probably between 20 and 30 db below full modulation.

MR. BERGER: Did the peak show up in the period of cycle of the wave? On some of the curves it looked as if it might be 200 cycles.

MR. KELLOGG: The little spots on the diagrams that mark the tips of the waves show about what happened. There was a little disturbance, followed sometimes by only one small reverse wave, and then the pressure would build up to practically full amplitude in the positive direction. In other cases, there would be a couple of waves. There were one or two cases where there was hardly any warning; and the first wave went as high as any of the succeeding waves.

MR. BERGER: Roughly speaking, would you say it rose up to its full magnitude, in the fastest one you found, in a hundredth of a second or less?

MR. KELLOGG: If the first wave shows full amplitude the pressure must build up from zero in about $\frac{1}{4}$ cycle, or in about $\frac{1}{600}$ second in the case of a 125-cycle wave. Of course, the higher-frequency components contribute to building up the peak, so that it is difficult to say just how quickly it is reached in the case of the most sudden build-ups. It should be remembered that starts of this kind are rather rare. I would like Mr. Drew to tell us his experience in trying to control the suddenness of beginning.

MR. DREW: It seems almost impossible for any given voice to deviate voluntarily to a slow build-up from what might be a very rapid build-up for that voice. For example, my voice has a very steep shoulder on almost all the vowel sounds. Mr. Kellogg's voice and some others that are about the same in frequency range seem to be very fast on the first wave. Other voices started more slowly, and the

initial waves were cone-shaped from zero to full amplitude. Many vain attempts were made by speakers with steep "shoulder type" voices to produce slow cone-shape build-ups.

MR. OFFENHAUSER: How would the rate of build-up of a single piano tone compare with the rate of build-up of certain of the speech tones you have shown? Have you noted any similarities?

MR. KELLOGG: We did not make any tests with a piano. Percussion instruments no doubt build up very fast, but I do not think the piano does come to full amplitude right away. Some of the percussion instruments no doubt would; but in the case of the piano the sounding board is large and heavy and there are numerous elements besides the strings which may resonate. As pointed out in the paper, musical instruments would not be played in dead rooms.

MR. ROSS: In voice culture four differing groups of consonant vowel formations are recognized. The first are the labials, as, for example, *pah, bah, mah, wah*, wherein the lips are involved. The second are the palatals, such as *tah, dah, nah, lah*, and *rah*, wherein the tongue is involved. The third are the labial palatals, as, for example, *fah* and *wah*, formed by both the lips and palate; and the last group are the gutturals, such as *kah* and *gah*. In the last group, the consonant formation begins at the vocal cords and accounts for the gradual, instead of abrupt, increase in amplitude of the sound produced, as shown by the first record referred to. The most explosive sounds are those produced by singing or speaking the pure vowels, as, for example, *ah, aye, ee, eye, oh, or you*.

MR. KELLOGG: We covered about all the types of sound we could think of, including those you mentioned. The examples are not sufficient in number, of course, to give anything of value statistically. It appeared from our tests that beginning a word with an unvoiced stopped consonant is not conducive to any greater suddenness than that which results if you simply start with the epiglottis closed and suddenly release your breath, but as Mr. Drew said, it does not seem possible to control the nature of the start entirely.

One conclusion that we seemed to be able to draw from our tests, and from the fact that so many sounds can begin suddenly, is that the human vocal cords are not like a cornet, where a return wave from an air-column would control the vocal cords and thereby establish when the next pulse comes. If a strong resonance of some kind were involved, such sudden beginnings would not be possible. The voice mechanism seems more like a relaxation oscillator that does not carry over any energy from one cycle to the next.

MR. ROSS: That is true. However when producing the pure vowel sounds, the maximum amplitude of sound is produced immediately without waiting for shading thereof by a preceding consonant. Therefore the initial recording will be of maximum amplitude.

MR. KELLOGG: That did not seem to increase the suddenness—rather the reverse. The voice sound with the lips closed produced a little preliminary modulation, enough for starting the operation of voice-controlled devices; and then the opening of the passage takes place over a period of several cycles. The increase is something like the action of swell in an organ—the pipes are sounding but the full volume outside is reached only gradually. I should like Mr. Reed to tell us something of the first observations of the consistent asymmetry of voice waves.

Mr. READ: About six years ago we were working with a neon volume indicator where the tubes flashed on only one-half of the wave. In the particular model, we had not taken the precaution to have all the tubes flash on the same half of the audio wave. On some speech sounds the lamps failed to break down in proper sequence, as they had done when calibrated with a sine-wave signal. We found that the lamps that were skipping were ones that were actuated by the portion of the sound-wave due to reduced pressure. Most of them worked on one polarity, while a scattered few were controlled by the opposite polarity. At that time we made extensive tests which proved that the effect was not due to any distortion in the system. We were using bidirectional microphones, so one test consisted in turning the mike around and talking into the other side. This resulted in different lamps flashing out of sequence.

Apparently such sounds consist of a series of impulses or shocks, the effect of each dying out before the next impulse occurs. It seems to come on the pressure-wave with most individuals; and, if you think about it, that is the easiest type of wave to generate. We attempted to generate a rarefaction—trying to suck the sound in is what it amounts to. Not many persons, it seems, are able to do it. It is reported that a few actors in Hollywood produce sound-waves where the instantaneous reductions in pressure exceed the instantaneous increases, which is, in other words, the reverse of normal speech.

VOLUME DISTORTION*

S. L. REICHES**

Summary.—The contention that a linear recording and reproducing system represents the ideal, and that sound handled by such a system will be exactly represented, is not borne out by experience. Systems have been built which meet this requirement within limits that are not detectable by the ear and yet these systems do not reproduce sound as it actually is produced. In many cases a definite non-linear response curve is provided to compensate for some factor that is not covered by the above contention. It is the author's thesis that this discrepancy is due to the ear sensitivity to frequencies as a function of loudness.

Using the ear-sensitivity curves presented by Fletcher and Munson of the Bell Telephone Laboratories (which have been verified by other observers) it is shown how the ear introduces frequency distortion to a linear system when the sound is reproduced at a level other than the level at which it is produced. It is shown how a sound reproduced above the incident sound-level introduces excessive low frequencies. The case for a sound reproduced at a lower level is also examined and the conclusion is drawn that this case accentuates the high frequencies.

It is further shown that the possibility of correcting for the limited volume range of all sound systems may lie in the type of amplifier response curve.

A description is given of three methods used to achieve the desired amplifier characteristics: (1) a mechanical method, (2) a linear-non-linear system, and (3) a selective by-pass system. Circuits are given and the important operating points of each are discussed. The objections to each system are also given.

Further, a brief summary, with diagrams, describes the various set-ups used to record with these amplifiers. This covers work for radio, disk record, and sound-film.

In the past the problem of recording and reproducing sound has been approached primarily from the standpoint of frequency and harmonic distortions inherent in the mechanical, electric, and chemical elements of the various systems employed. So much progress has been made toward the elimination of these distortions that, today, it is quite correct to say that frequency and harmonic distortion can be held within limits that are not objectionable. Now that these system distortions have been corrected, it seems that a detailed examination of the effect of reproduction volume should be made.

* Presented at the 1939 Fall Meeting at New York, N. Y.; received August 28, 1939.

** Case School of Applied Science, Cleveland, Ohio.

Although data have been compiled by Fletcher and Munson of the Bell Laboratories, and although many have noted the effects of volume on quality, there seems to have been no detailed analysis made of this effect.

This paper proposes to analyze this effect, and to indicate methods of correcting the distortions produced.

I. OCCURRENCE OF DISTORTION

Ear-Sensitivity Curves.—Fletcher and Munson have shown that the ear does not respond to all frequencies with the same sensitivity. In

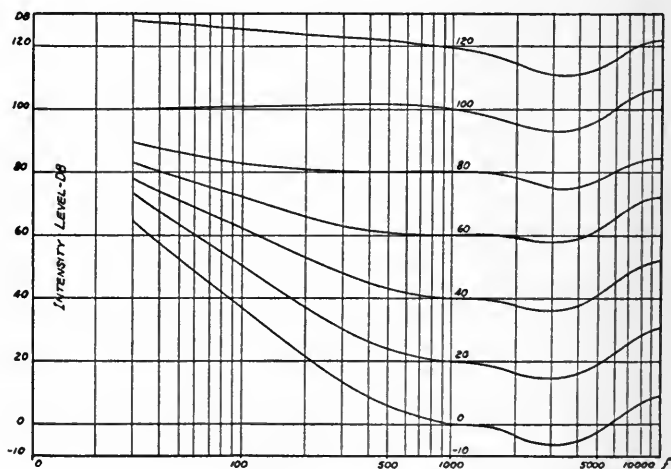

FIG. 1. Ear-sensitivity curves.

addition, they have shown that the ear varies in sensitivity to frequencies as a function of the loudness of the incident signal.

Fig. 1 shows the ear-sensitivity curves of Fletcher and Munson. As these curves are not straight lines, they show what, in an amplifier, is termed frequency distortion. However, this fact is not the salient point of the curves.

The important point is that the slopes of the curves at corresponding frequencies are not the same for all curves. If the slope were the same then the ear would hear all signals, at all loudnesses, in the same proportion of energy at the various frequencies. If this were true there would be no distortion to the ear.

Examination of these curves shows that the condition of equal slope is substantially met at frequencies above 1200 cycles. That this is fortunate will be shown when the amplifier design is discussed.

Implication of Curves.—The implication of these curves can best be shown by an illustration. Consider a system carrying a 100-cycle note and a 1000-cycle note, each containing the same energy represented by 80 db. Fig. 1 shows that the ear will hear the 1000-cycle note as an 80-db note while the 100-cycle note will be heard as an 83-db note.

If the system gain is lowered 40 db, the intensities of the two notes are actually 40 db but are heard by the ear as sounds of 20-db difference.

Distortion Produced as Function of Curves.—To illustrate the result of this effect, assume that it is desired to record a sound of uniform intensity at all frequencies. Also assume this sound occurs at 50 db.

To an observer on the set the various frequency components of this sound will actuate his ear in a manner shown by the ear-sensitivity curve for 50 db. However, the electrical system recording this sound is built to receive uniform electrical energy. Therefore, the electrical system does not record the sound in the same manner as heard by the observer. And due to the varying ear sensitivity of the observer as the loudness varies, the amount of distortion between the observed sound and the recorded sound varies.

Condition for No Distortion.—From this it follows that the condition for no distortion is that reproduction should occur at the same level as the incident sound. When this is done the reproduced sound will be heard by the ear of the observer in the same manner as the observer would hear the sound as it occurred on the set.

If this is not done, distortion is introduced.

Effect of Reproduction Level above Incident Level.—If reproduction takes place at a level above the incident level the effect is to accentuate the low frequencies. This is shown by Fig. 2. The curves are found in this manner:

Assume a constant-energy sound occurs at 20 db and is reproduced at successively higher levels. At 20 db the ear has one response. The difference between each higher response curve and the 20-db response curve, at various frequencies, is the error introduced. The curve thus found from Fig. 1 is the sensitivity difference. The conjugate of these curves gives the apparent added energy at the low frequencies. These are shown by Fig. 2.

Effect of Reproduction Level below Incident Level.—By similar analysis Fig. 3 is found. Here it is shown that reproduction at a lower level than the incident level produces an exaggeration of the high frequencies.

Condition of Varying Energy Signals.—The static condition has been discussed. Examination of the varying energy case will now be made. If a sound begins at a given level and is reproduced at another level, a certain error curve is determined. However, if the sound increases in level, the reproduced sound increases in the same amount, but the error curve is different.

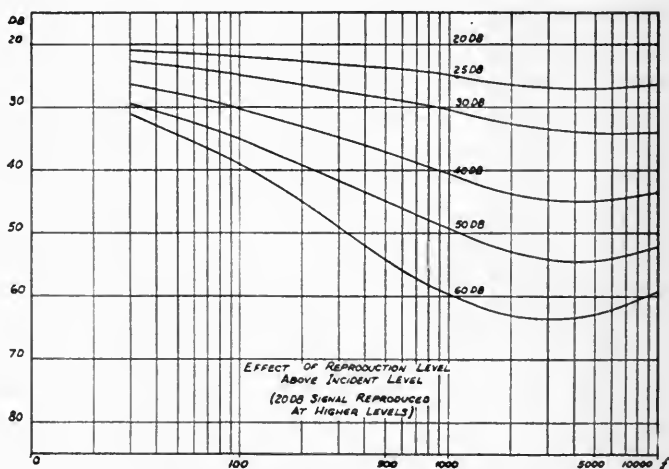

FIG. 2. Effect of reproduction level above incident level.

Specifically, a sound of 20 db reproduced at 30 db will generate one error curve. A 5-db rise in incident sound will raise it to 25 db and the reproduced sound to 35 db. The error curve for the 20-30 db combination is different from the error curve for the 25-35 db combination.

Therefore, it is seen that an infinite number of curve combinations occurs for the infinite possible combinations. And it is also seen that a static response curve will not correct this error.

Effect of System Range.—The above example considered the incident sound as continually increasing without limit. However, all recording systems have a maximum level that can be recorded. When this top point is reached the incident level continues to increase but

the reproduced level remains at the maximum the system can handle. After this point is reached the error curves produced represent the difference between the ear-response curve at the top of the system range and the increasing incident sound-level.

This points out the possibility that this type of error can be corrected by adjusting the response curves of the system, and thereby simulate the effect of increasing loudness without an actual increase in power output.

Application of Correction.—Correction for volume distortion is dependent on the system to which it is applied. Theoretically the following should be done: As will be pointed out later the actual correction can be done quite readily at the recording end.

Radio.—It is not to be assumed that all radio receivers are played at the same loudness, nor can it be assumed that any has a linear response. Therefore, it would seem that any correction should be applied to the receiver proper.

On the other hand, the average radio has a range of about 35 db. As there is no metering element that may be introduced at the receiver to compensate for distortion due to system limitations this type of volume distortion should be corrected at the transmitter. The correction should compensate for the lower level of reproduction, which accentuates the high frequencies.

It seems that from the above theory it may be concluded that the layman who uses all the bass obtainable with his tone control, and the layman who insists that acoustic labyrinths, baffles, and resonance chambers be added to his radio is more correct than is the engineer who insists on linear response at all levels.

Records.—Substantially the same may be said with respect to disk records as is said for radio except here the system range is about 55 db.

Sound-Film.—Sound-film systems represent a different condition. In these it is necessary to correct for a reproduction level above the incident level, which accentuates the low frequencies. It is necessary also to correct for system limitations.

Correction may be applied at the reproduction end but advantage should be taken of the fact that most reproduction occurs at approximately the same level and this allows correction to be made at the recording end. An advantage gained by correction at the recording end is that film noise, occurring mostly in the high frequencies, is blanketed by the excessive highs introduced in recording.

Actual Correction.—Fortunately it has been found possible to correct at the recording end in all cases. This is a great advantage and is done on the assumption that approximate reproduction levels may be assumed. Investigation shows that radio reception occurs seemingly at all levels. One trouble introduced by radio is the limited frequency response of receivers. Although stations transmit a 10,000-cycle band a good commercial receiver will cover only 3500 cycles.

Conclusions.—The major points that may be concluded from this discussion is that no static response curve for a system, because of

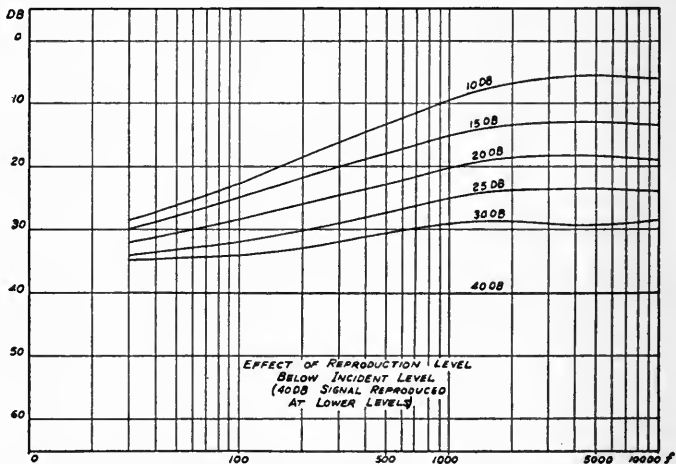

FIG. 3. Effect of reproduction level below incident level.

the varying ear response curves as a function of loudness, can record and reproduce a sound exactly.

A point that should be mentioned is that this theory is based on the average ear response curves. Therefore, assuming that the system response may be continually adjusted, these adjustments will fit only one observer. However, it must be borne in mind that the ear-sensitivity curves could not be presented unless there is agreement between test subjects within at least 25 per cent. If this is true then correction will be 125 per cent for one observer and 75 per cent for another.

If it is assumed that there are some ears that respond in a totally different fashion, then this correction will not please that observer.

Another point is the case of specially trained ears, such as the musician. His response curves may fit the average within the 25 per cent limits, yet due to his education on musical sounds this correction may not please him.

These points seem to be the limiting factors in the correctness of this interpretation of the effect of the ear response curves on a recording system.

II. CORRECTION OF DISTORTION

Part I of this paper has attempted to explain the origin of volume distortion and evaluate the magnitude of this distortion.

The salient point indicated for correction of this distortion was the explanation showing that a static characteristic curve for a reproducing system was not sufficient. The system must have a varying response curve. This response must vary as a function of loudness, or energy input to the system, and also as a function of the output loudness of the system.

The curves that represent the characteristics of these systems can be found as indicated in Part I as the conjugate curves of the error curves shown in Figs. 2 and 3. This means that the curves of the system are not finite in number. For every condition of incident loudness compared to reproduced loudness there exist system curves that are different.

This makes necessary the adoption of reproducing levels to work around and also the use of approximations for response curves. Therefore, although the general trend of the correction curves can be established, the final arbiter of the desired curves is the ear.

With this in mind the work on achieving correction was conducted along three lines. All were thoroughly investigated and one adopted and now in use.

Assumption.—To form a basis upon which to design the requisite amplifiers it was necessary to determine the average loudness of reproduction of the various systems to which this correction is to be applied. When these levels are determined it is possible to determine the successive error curve for each loudness level above this average level and then correct between these curves by proper amplifier design.

Two methods for determining these error curves present themselves. It is possible to assume that the reproducer level remains constant, and then draw the curves showing the error between this level and

the succeeding increasing levels. Second, it is also possible to draw the curves between the assumed level of reproduction and the incident level producing this reproduction level, and then draw the error curves for each successive increment of input to output.

Determination of Levels.—A pure tone is sent over a line and is reproduced. A series of observers in an average size room adjust the level until it is adjusted to their impression of the loudness their receiver would be played. This loudness is measured and is used as the level for both radio and disk records. The same follows for film work. As it is necessary to determine only one level, by the assumption made above, the requisite curves can be drawn.

To check these figures a set-up was made enabling a conversation at normal levels to be measured after the loudness has been set by several observers.

Definition of Average Loudness.—For the purpose of the problem there can be said to be three different loudnesses for each subject recorded. These may be termed (1) general loudness; (2) specific loudness; (3) instantaneous loudness.

Any sound occurring over a period of time may be said to have these three factors:

(1) General loudness is the average loudness of a sound over the duration of its occurrence. This is the average loudness referred to when an average level is denoted for a given sound. This is the loudness for which the equalizers are used.

(2) Specific loudness is the average loudness of a sound for an interval of time much less than the duration of the sound. This is the loudness referred to when it is said the loudness of a sound varies between 30 and 60 db.

At any interval of time less than the time for the general loudness but greater than the audio-frequency changes there is a specific loudness. This is the loudness variation that should be corrected by the amplifier.

(3) Instantaneous loudness is the loudness that varies with the envelope of the audio-frequency.

Amplifier Considerations.—It was decided to build a standard amplifier so that control would be had over the high frequencies. If the high frequencies are to be varied it can be seen that the type of variation, whether an increase or decrease, must depend upon whether reproduction takes place above or below the incident level; that is, for a reproduction level below the incident level it is neces-

sary to add low frequencies or subtract high frequencies. As the level rises the amount of lows added must decrease. When the reproduction level is above the incident level the correction which consists of an excess of high frequencies must also decrease.

In terms of an amplifier that controls only the high frequencies this means that the louder the source becomes the more highs must be added for a low-reproduction level and subtracted for a high-reproduction level.

This is self-explanatory with a lower reproduction level. It is desired to add highs as the level rises. Therefore, the highs can be

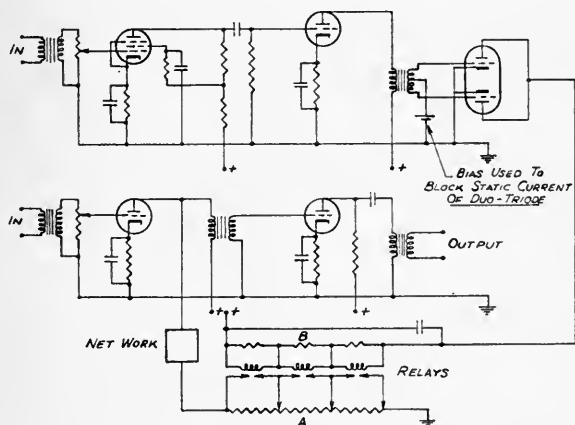

FIG. 4. Mechanical response control.

increased. However, if the highs are removed from the high-reproduction case the distortion will be exaggerated. This is adjusted by the equalizer. The equalizer produces the average correction curve which raises the high frequencies to a point above a linear response and the A. R. C. amplifier, as a function of the signal, will cause highs to be removed.

If the A. R. C. amplifier is to swing about the average correction curve it will be necessary to have the A. R. C. change about a line other than a linear response; also this line would vary for each reproduction case. However, if the equalizer is adjusted to fit the low points of the signal, the A. R. C., varying from a linear curve, will fit all cases.

Mechanical System.—This method takes advantage of relays that operate on small currents of the magnitude of 1 to 1.5 milliamperes. A group of fifteen relays was used. They operated as a function of signal magnitude. These relays are connected (Fig. 4) in conjunction with resistance *A* such that on being actuated a definite portion of this resistance, which is in a series with an equalizer network, is removed, and the resistance of the line from the network to ground is decreased. These steps were of the order of 1 db.

The relays are operated in series with the plates of a tube operated in Class *B*. Thus the increase in signal increased the plate current, which in turn actuated the relays. The progressive operation of the relays is adjusted by means of resistors *B*.

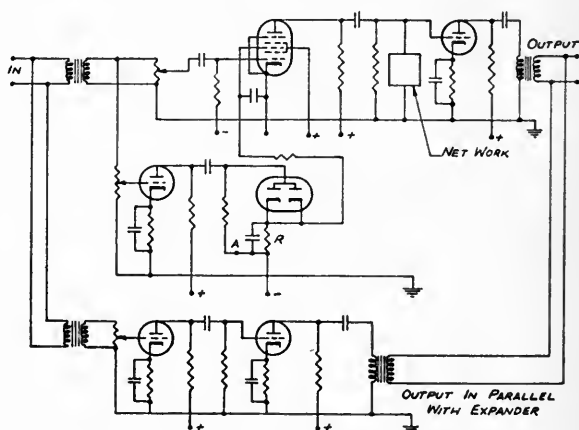

FIG. 5. Linear-non-linear combination.

Condenser *C* is used to by-pass the audio in the plate line of the Class *B* tube. This is necessary as the audio induces a signal in the contact arms of the relay and is fed back to the main signal line.

Although this system can be made to operate there are several objections to its use. The obvious objection is the number of parts which must be adjusted regularly. In operation the unit is very noisy and this noise appears electrically as clicks. These clicks may be suppressed to some extent, but they remain objectionable.

In addition to this the usual action of a relay, opening at a current less than the closing value, causes some trouble. The relays used in this test were sufficiently fast and were not troublesome in this re-

spect. Because of these reasons, as soon as the unit was built and proof was had that the system would work to some extent, the work was discontinued.

Linear-Non-Linear Combination.—Another method tried was the combination of a linear and non-linear amplifier. Linear and non-linear refer to the ratio of signal input to signal output rather than frequency response.

The linear amplifier was a typical voltage amplifier. The non-linear amplifier took advantage of changing the gain of a multigrid tube as a function of the bias on the one of the grids. This circuit is shown in Fig. 5. The bias of the multigrid tube is varied by the

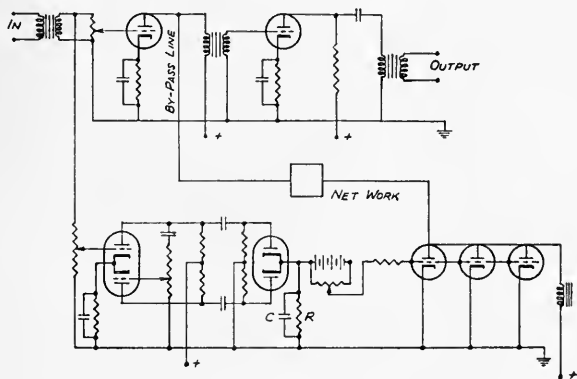

FIG. 6. Selective by-pass circuit.

change in d-c voltage developed across R by the current from the diode rectifier.

The gain of the non-linear amplifier plus the action of the expansion delay voltage, which may be added at A (Fig. 5), allows control of the shape of the combined response curves as a function of loudness.

This system works but has one very bad objection that is inherent in the non-linear amplifier. The expansion action, being a function of the grid bias of the expander tube, will occur without harmonic distortion only within quite narrow limits. And as the expansion required is quite high, distortion is quite bad.

In addition to this another point enters, in that the d-c bias control voltage contains half-wave audio which feeds back to the main signal line on heavy signals.

The third objection to this method is that the expansion action of the non-linear amplifier increases the power delivered to the line. These sudden surges are impossible to catch with manual monitoring. A peak-limiting compressor can handle some of this. But at best this is an objectionable feature.

Selective By-Passing.—This method, which was finally adopted as the most desirable, consists of a system for by-passing selected frequencies as a function of loudness. Fig. 6 shows the circuit for this method.

The voltage amplifier has substantially a linear frequency response. To this is added the by-pass line. The line consists of a condenser in series with a variable resistance. This variable resistance is the plate-to-cathode resistance of a triode tube.

The resistance of this tube is controlled by the d-c impressed on its grid, produced by a diode pair in full-wave rectification. The diodes are driven by a duo-triode with one section used as an inverter. The d-c voltage used is positive and is developed across R . The condenser is for filtering action. The battery in series with the positive d-c voltage is of great importance.

For a low-level signal a linear frequency response is desired. Therefore there should be no by-passing through the condenser and tube. This means that the tube should be blocking, and theoretically of infinite resistance. This is achieved by means of the battery. This battery swings the grid of the by-pass triode sufficiently negative to block the tube, and to block it enough for a given gain on the d-c source that no by-passing occurs until desired.

As soon as the signal level increases, the d-c from the diodes increases and, with the same battery voltage, the effect on the grid is to make it less negative. This decrease in bias on the tube lowers its resistance and current is by-passed.

The circuit shows several by-pass tubes in parallel. There are several reasons for this. The typical triode used in this circuit has a plate resistance of 10,000 ohms, 15 volts on the grid at 135 volts plate. That means that only a 15-volt d-c swing is required from cut off to minimum resistance. This can readily be produced across resistor R and filtered with condenser C and a very short time constant can be obtained.

On the other hand, if a tube is used such as one with 800 ohms' plate resistance, 60 volts on the grid and 250 on the plate, the d-c swing must be 60 volts. This would entail, assuming that enough current

would flow from the diodes, a larger resistance and larger condenser. The time-constant would be very large and the action would be very sluggish. In addition, the grid would need about 100 volts negative to block. This means larger batteries.

Therefore the multiple-tube arrangement was evolved. By increasing the number of tubes used the resistance of the by-pass could be made any minimum value. This gives a wide latitude of resistance change and works out very nicely.

Feedback.—The by-pass line with its tubes is actually a method for introducing to the main signal line the rectified d-c "hash."

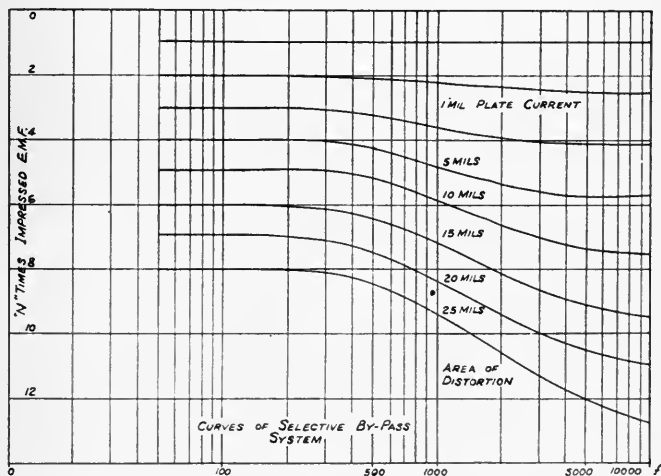

FIG. 7. Curves of selective by-pass system.

Due to a fortunate choice of constants for the various elements, the by-pass line, in the amplifiers now in use, is coupled directly as is shown in Fig. 7. With this arrangement the feedback is so small that no distortion is detectable with the ear.

Before this combination was arrived at several feedback suppression devices were developed.

These may be used if too much distortion due to feedback occurs.

Reflection.—Reflection at the by-pass line in the system, due to the major changes in the impedance of the by-pass line, does not occur in detectable form until extremely high signals occur.

Full-Wave Rectification.—A word should be said as to why full-wave rectification is used in place of the mechanically simpler half-

wave. This is because less filtering is needed in full-wave rectification, and second, it was felt that some advantage would be gained if the envelope were a more exact replica of the audio than could be obtained with half-wave rectification. This is because of the non-symmetry of the audio about the reference axis.

Range of System.—This arrangement is capable of by-passing as much as 30 db at 10,000 cycles.

Microphones.—Due to the effect of the amplifier it seems that best results are obtained when a "live" microphone, such as the "eightball," is used.

Other microphones can be used but require some adjustments in the response of the line amplifiers. These adjustments consist in

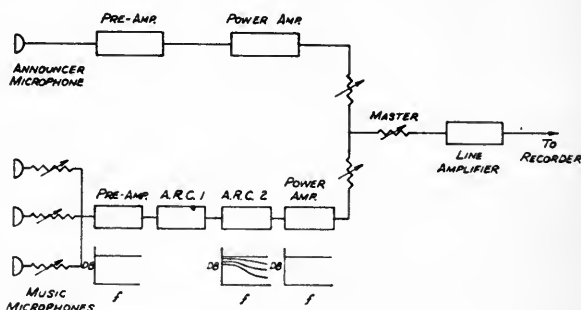

FIG. 8. Typical amplifier arrangement for radio and records.

raising the high-frequency response of the line amplifier to compensate for the bass response of the microphones.

III. APPLICATION OF CORRECTION

Although some measure of success was had in the design of the required amplifiers, the problem remained to develop a technic for the use of the amplifiers.

In the usual recording set-up, whether for disk records, radio, or sound-film, the microphones are judiciously placed according to past experience. The microphones are fed to pre-amplifiers. The output of the pre-amplifiers is fed to the line amplifiers and then to the recording unit. Gaining is usually done before the line amplifiers. The gain is adjusted to the requisite level and is independent of the

input sound energy. This can not be done with the automatic response control (abbreviated A. R. C.) amplifier.

General Consideration.—In this amplifier the frequency characteristic is a function of the voltage applied to the grids of the tubes. Because of this the input to the device must have such a value, for a given input to the microphone, that the proper response curve will appear for the A. R. C. amplifier. Also, if it is desired to have the amplifier correct for the distortion produced by the system limit, all gaining must be done after the A. R. C. amplifier.

Typical Radio Set-Up.—In radio there are two types of sound to be considered, speech and music. Investigation will show that the error produced in radio for speech occurs because of a higher reproduction level than incident level. Music, as was pointed out before, produces errors in the other direction.

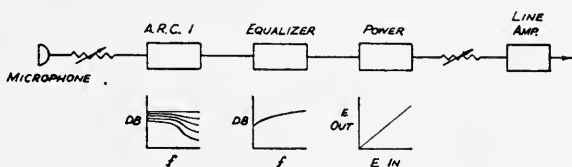

FIG. 9. Typical arrangement of amplifiers for sound recording.

It was decided that the error for speech was not worth correcting because the error is so small in most cases, and also, in a musical program, the announcer was only a small part of the show. Therefore the arrangement of Fig. 8 was used.

As is typical, the announcer feeds through a separate microphone and amplifier system to the main control board. The musical program is fed through a preamplifier to the A. R. C. then to a power amplifier and finally to the master control panel. This arrangement proves satisfactory for the studio and remote pick-up.

Network Pick-Up.—Here another problem presents itself because the announcer's voice is fed to the chain at the same level as is the music. Therefore, the A. R. C. will respond to the voice in the same way as music does. This causes bad distortion for voice. The only way in which this type of pick-up can be used is to by-pass the A. R. C. whenever the announcer talks.

Records.—The same arrangement is used for records with the exception of the announcer's microphone.

Sound-Film.—In sound-film recording the same general considerations presented for radio hold except for the announcer's microphone. Here, however, the amplifier line-up is quite different. As was shown, the type of correction is different and a different A. R. C. is needed. A recommended installation is shown in Fig. 9.

Determination of Levels.—To determine the average levels about which correction would be made, advantage was taken of the amplifier as a loudness meter at the recording end, and a typical amplifier loudness meter was used at the reproduction end. The automatic response control amplifier was calibrated from the commercial loudness meter. Loudness was measured at the distance of the microphone from the source.

In reproduction, the distance from the reproducer at which loudness is measured is debatable. In a receiver a distance of six feet was used. For sound-film, possibly, the center of the auditorium in line with the screen is a good point.

The desirable method would be to use a constant-energy sound which, when placed at the desired distance from the microphone and adjusted to the proper loudness, would create linear response curves for the A. R. C. This linear condition is easily determined by the magnitude of the by-pass triode plate current.

Re-Recording.—In re-recording existing sound copies (either disk records or film) the improvement can be only within the volume range of the present record. The problem here is to determine input levels from the pick-up to the A. R. C. At present disk records are copied with the by-pass plate current meter deflecting an amount determined by the type of sound being re-recorded.

IV. CONCLUSION

It is believed that this paper presents some new concepts on the problem of recording sound whether in radio, for wax records, or sound-film. The theory discussed is naturally quite general because of the many different ear-sensitivity curves. Yet it is sufficiently accurate so that an amplifier with only approximate correction curves records sound that, in the opinion of the great majority of listeners, is more realistic than that provided by present-day methods. It has been found that corrections are worth more, the greater the difference between the incident level and the reproduced level.

The greatest handicap in this work was the lack of live pick-ups that could be used for test purposes. Because of this it is not pos-

sible to say that the A. R. C. improves everything that passes through it. Much more work must be done along these lines.

The shape of the response curves has been shown to be moderately critical. It has been found that the closer these curves approach the ideal the greater is the apparent improvement. Much more work can be done to improve these curves. No mention has been made of public address systems and electrical musical instruments. Some work has been done at the level of public address systems in conjunction with sound-film. However, a complete analysis can not be presented as yet.

Acknowledgment.—The writer expresses his appreciation to Professor John Martin, of the Department of Electrical Engineering, Case School of Applied Science, for his many suggestions; also to Mr. R. Morris Pierce, Chief Engineer, and Mr. Lawrence Shipley, Assistant Chief Engineer, respectively, of Station WGAR, for their coöperation in permitting the use of the station's facilities and for their encouragement and direct solutions of many of the problems that have turned up in this work.

LENSES FOR AMATEUR MOTION PICTURE EQUIPMENT* (16- AND 8-MM)

R. KINGSLAKE**

Summary.—In all motion picture photography and projection, lenses of high relative aperture must be used. However, on account of the small size of the amateur frame, the focal length is short, and the linear aperture of the lens is therefore small, resulting in considerable depth of field. Thus in cine work, great lens speed is not automatically associated with small depth, as is the case in ordinary photography.

Moreover, as the entire motion picture frame must be seen by the eye at a glance, the angular field covered must be much smaller than in still pictures which may be examined critically and deliberately. This fact is of the greatest assistance to the lens designer because high aperture and field are inevitably somewhat incompatible, and types of lens construction which favor aperture generally cover a relatively small field.

Perspective considerations usually require a projection lens covering only about half the angular field covered by the taking lens, which fact enables projection lenses of very high relative aperture to be made. Some of the types of construction commonly used in amateur cine lenses are described.

Perspective Considerations.—The lenses used in amateur cine cameras imitate those used in professional work with 35-mm film in one important respect, namely, angular field coverage. If a professional lens of 50-mm focus covers a 35-mm sound-frame measuring 16×22 mm, having a diagonal of 27.2 mm, the angular semifield to the corners of the picture is 15.2 degrees. In the amateur sizes, with a 16-mm frame having dimensions of 7.5×10 mm, the picture diagonal is 12.5 mm and the semifield to be covered by lenses of various focal lengths is as indicated in Table I. The cine-eight frame is just one quarter of the 16-mm frame, and has a diagonal of 6.25 mm.

It is thus clear that lenses of those focal lengths which are normally used in cine work operate at a much smaller angular field than the lenses on ordinary still cameras, which usually cover about 24 degrees.

The reason for this is that the eye can take in a semifield of only some 12 to 14 degrees at a glance. Thus in a motion picture in

* Presented at the 1939 Fall Meeting at New York, N. Y.; received October 13, 1939.

** Eastman Kodak Co., Rochester, N. Y.

which the eye must follow action covering possibly the entire frame, a semifield of only 12 to 14 degrees is desirable at the observer's eye during projection. Now, the rules of correct perspective rendering tell us that all angular relationships in the final picture as seen by the observer should be the same as those which existed in the original subject as seen from the camera lens. Thus if a scene appeared 24 degrees wide to the original camera, its projected image should be viewed from such a distance that it also appears 24 degrees wide to the audience.

Since the average position of the audience may be perhaps midway between projector and screen, it is necessary that the focal length of

TABLE I

Angular Semifield Coverage (Degrees) in Amateur Cine Cameras

	Focal Length		16 Mm	8 Mm
	Inches	Mm		
		5	..	32.0
		7.5	..	22.6
		10	..	17.3
0.5		12.7	26.2	13.8
		15	22.6	11.8
		20	17.4	8.9
1		25	14.0	7.1
1.5		38	9.3	4.7
2		51	7.1	3.5
2.5		64	5.6	..
3		76	4.8	..
4		102	3.6	..
4.5		114	3.1	..
6		152	2.4	..

the projector lens should be about twice that of the taking lens (Fig. 1) and the angular field covered by it is therefore only about half that covered by the taking lens. Thus if a focal length of 25 mm is adopted as the standard for taking lenses, the standard home projection lens should be of 50-mm focus. Of course in a much longer hall, if the audience is fairly close to the screen, longer focus projection lenses should be used.

The wider (25 degrees) field of a still camera is justified because, the picture being still, the eye has an opportunity to scan it and study each part separately. But in this case also, the perspective will be correct only if the eye is at the correct viewing distance, which is

such that the angular size of the picture appears equal to the angular subtense of the original subject at the camera lens. This distance is equal to the camera lens focal length multiplied by the enlargement ratio in the print.

Choice of Lens Aperture.—In all photographic lenses, a high relative aperture is desirable to shorten exposures. In cine work, however, the exposure is ordinarily fixed, and then a high aperture is valuable to facilitate photography in a poor light or indoors. Fortunately, the use of short focal lengths enormously increases the depth of field,

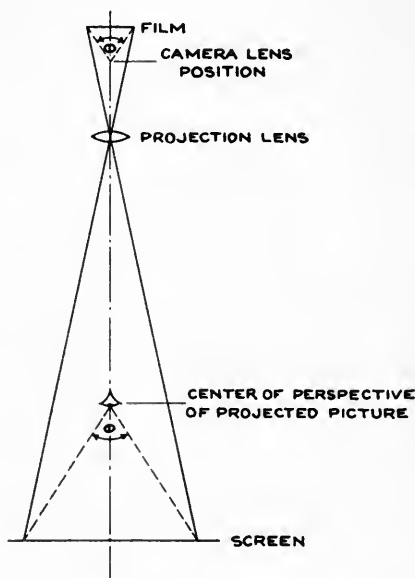

FIG. 1. Perspective of Projected Images.

because depth of field depends only on the distance of the object from the camera and on the *linear* aperture of the lens. Thus an $f/2$ lens of 25 mm focus has a clear linear aperture of 12.5 mm, and this lens therefore has the same depth of field as a 100-mm lens at $f/8$. In cine-eight cameras, the standard focal length is only 12.5 mm, and an aperture of $f/2$ has the same depth of field as a 100-mm lens at $f/16$.

Sharpness of Definition.—If the audience is situated at approximately the correct center of perspective for the projected picture,

the angle relationships on the projection screen as seen by the viewer must be the same as the angle relationships in the original film as seen from the second nodal point of the taking lens.

Suppose therefore we are at the limiting stage of critical definition when the screen image is just beginning to lose sharpness as seen by the audience. Then each point will be imaged on the screen as a tiny blur-circle subtending an angle of about 1 in 2000 (1.7 minutes of arc) at the eye. This corresponds to a circle of confusion on the film of diameter equal to $1/2000$ of the focal length of the taking lens, and if that lens has a focal length of one inch (25 mm), the circle of confusion will be just on the verge of spoiling the definition when it has a diameter of $1/2000$ inch or $1/80$ mm.

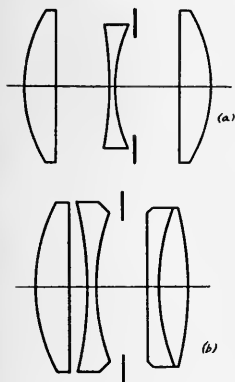

FIG. 2a. Triplet lens.

FIG. 2b. Tessar lens.

The graininess of reversal films is of this order; hence graininess will usually be just visible on the screen when properly viewed, and it will certainly be visible to a member of the audience who is too close to the screen. However, as the grain pattern in successive frames is entirely different, persistence of vision tends to smooth it out and the graininess is therefore usually not objectionable. Moreover, a moving object may be imaged decidedly unsharply as the motion, together with persistence of vision, helps our interpretation to a great extent and makes very sharp definition unnecessary.

We may therefore conclude that a taking lens must form an image-point which is less than $1/80$ mm diameter if satisfactory definition is to be obtained. This applies, of course, over the entire frame, but it is less important at the corners since the major attention is generally paid to details and action in the center of the picture.

Since sharpness of definition is fundamentally an angular quantity, it follows that if a particular lens formula gives acceptable definition in one size it will also be acceptable in all sizes, provided the final picture is viewed from the correct perspective center. Thus cine lenses gain nothing on account of their short focal length, for an 8-inch lens must give a sharpness corresponding to a circle of confusion of about $1/10$ mm, and a 1-inch lens must give $1/80$ mm. The same lens formula made in 8-inch and 1-inch sizes would therefore

provide lenses which are equally good, if the final viewpoint is always correctly chosen.

However, in using interchangeable cine-camera lenses, say from 1 inch to 6 inches in focus, the pictures are viewed in succession from the same viewpoint, and thus the 6-inch lens and the 1-inch lens must both give a $1/80$ -mm circle of confusion. This puts a great demand upon a 6-inch lens, as it must be relatively 6 times as good as the 1-inch lens. On the other hand, the angular field is only one-sixth,

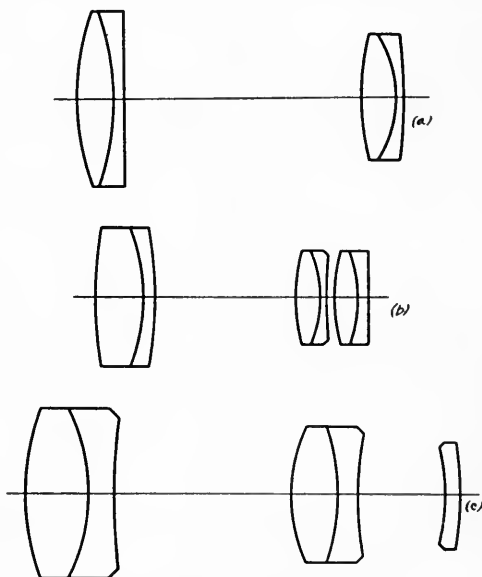

FIG. 3a. Petzval type $f/1.6$.

FIG. 3b. Petzval type $f/1.3$.

FIG. 3c. Petzval lens with field flattener.

so a design may be employed for these very long-focus lenses which stresses central definition entirely at the expense of field.

Types of Lens Construction.—Any type of lens may be used for cine purposes, but as high relative apertures are desirable, the actual choice of lens types is really rather limited. However, since the normal angular field is small (14 degrees), a number of types may be used which could never be made to cover the 24 degrees demanded in a still camera. It is well known that aperture and field are more or less incompatible, and we may secure much higher apertures if we are willing to sacrifice angular field.

For apertures of $f/3.5$ or $f/2.7$, lenses of the regular triplet or Tessar types may be used (Figs. 2a and 2b). In these cases, a field as wide as 22 degrees may be covered without difficulty, and such forms lend themselves to the construction of "wide-angle" cine lenses which are lenses covering a wider semifield than 14 degrees.

Above $f/2.7$, the choice of lens type becomes much more limited. The Petzval portrait lens (Fig. 3a) is an obvious choice and has been modified to give apertures as high as $f/1.3$ (Fig. 3b) but this really does not cover as much as 14 degrees. Indeed, at apertures higher than $f/2$, this type will not give acceptable definition much beyond 7 degrees from the axis. The angular field may be increased by the use of a concave "field flattener" lens placed close to the image plane (Fig. 3c).

In the normal type portrait lens with cemented components, all the correction is done by the two negative cemented surfaces. Thus the crowns must have a lower index than the flints, borosilicate crown and ordinary dense flint being the usual choice. However, if the two doublets are separated, and the crowns and flints are "bent" independently, a strong negative air-lens may be inserted between the crowns and flints, and a high-index barium crown may then be employed. This at once reduces the

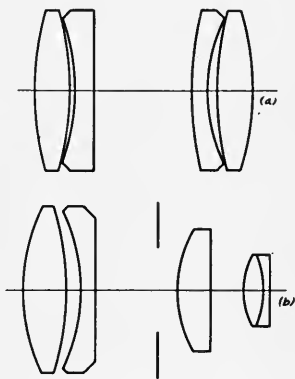

FIG. 4a. Kodak $f/1.9$ cine lens.

FIG. 4b. The R-Biotar $f/0.85$.

Petzval sum of the system and enables a much wider field to be reached before the astigmatism begins to spoil the definition.

The Cine Kodak $f/1.9$ lens is of this type (Fig. 4a) and was first described by Frederick.¹ By extending this process, the R-Biotar $f/0.85$ was designed by Merté in 1934² (Fig. 4b).

The Petzval type can be used as a taking lens of high aperture in the longer focal lengths, provided a semifield of less than 7 or 8 degrees must be covered. Such lenses give brilliant pictures, free from haze and scattered light, and have been extensively used in focal lengths of $2\frac{1}{2}$ inches or more on 16-mm film.

If an aperture greater than about $f/2$ is required, at a field of 14 degrees some other type of construction must be adopted. Innumerable attempts have been made to solve this problem, and almost

every lens manufacturer has made cine lenses having apertures anywhere from $f/0.85$ downward. A popular type is the Planar described by Rudolph³ in 1897 (Fig. 5a).

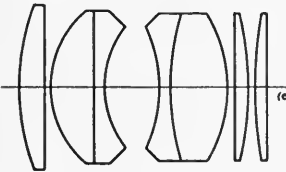
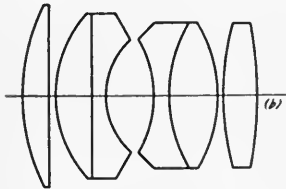
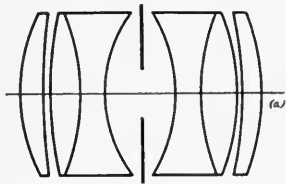

FIG. 5a. Planar $f/4$.
 FIG. 5b. Biotar $f/1.4$.
 FIG. 5c. Xenon $f/1.3$.

The original Planar worked at $f/4$ and covered a 25-degree field. It was symmetrical, and used glasses such as were available at that time. In 1921, Lee in his "Opic" lens⁴ raised the aperture to $f/2$ by departing from strict symmetry and using other types of glass. In 1927, Merté developed the $f/1.4$ "Biotar"⁵ (Fig. 5b) by introducing stronger surfaces and still greater asymmetry, to cover a field of 14 degrees for cine purposes. Many other modifications of this type have been made with varying degrees of success. This type of construction leads ordinarily to a very flat field with good axial spherical correction, but it tends to suffer from considerable spherical aberration in the oblique pencils. This does not detract from the definition, but it may introduce some slight haze and lack of contrast in the outer parts

of the field, especially on over-exposure. By using two single lenses in the rear component, some further benefits may be derived, as in the Xenon $f/1.3$ lens (Fig. 5c).



FIG. 6. A telephoto lens.

Telephoto and Wide-Angle Lenses.—The true telephoto lens comprises two widely separated members, the front being positive and

the rear negative. The "telephoto magnification" is then often defined as the ratio of the overall focal length to that of the front member alone. True telephoto lenses have been made at apertures approaching $f/3.5$, with a telephoto magnification usually of about 2.0. The advantage of the telephoto lens is of course its compactness, but the disadvantages are that with this type of construction it is not possible to secure either a high aperture or the very finest

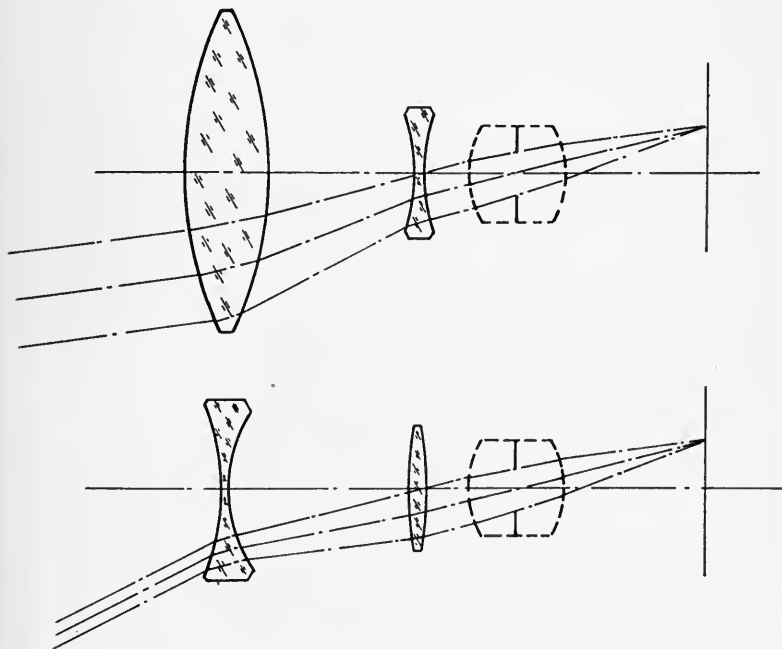

FIG. 7. Telephoto and wide angle attachments.

degree of aberration correction. Consequently, in the short focal lengths required in amateur cine work, it is common to use a normal lens in place of one of the strictly telephoto type.

A "wide-angle" lens in cine work implies one covering a semifield of more than 14 degrees. Thus a regular camera lens covering 24 degrees may be made in 15-mm or 20-mm focal length as a "wide-angle" lens for 16-mm film.

• *Telephoto and Wide-Angle Attachments.*—These are merely specially designed forms of Galilean telescope intended to be added in front of

the regular lens on the camera. If the positive lens is in front, a magnifying action is produced, and if the negative lens is in front, the result is a wide-angle effect.

In some of these attachments, focusing may be done by increasing the separation between the components. Of course, when such an attachment is in use, the regular focusing scale on the camera lens becomes meaningless.

It should be noted that these attachments do not affect the f -number of the lens, but only its equivalent focal length and hence its angular field.

Kodak 16-Mm and 8-Mm lenses.—In the 16-mm range is the following series of taking and projection lenses. (After each lens is indicated the number of the illustration in which the type of construction is indicated.)

<i>Taking</i>			<i>Projection</i>		
Focus	Aperture	Fig.	Focus	Aperture	Fig.
15 mm	$f/2.7$	2a	1 inch	$f/1.9$	4a
25 mm	1.9	4a	1½	2.0	4a
2 inch	3.5	2a	2	1.6	3a & 3c
2½	2.7	3a	3	2.0	3a
3	4.5	6	4	2.5	3a
4	2.7	3a	4	1.6	3a
4½	4.5	6			
6	4.5	6			

For the cine-eight, the following lenses are available:

12.7 mm	$f/3.5$	2a	1 inch	$f/1.6$	3a
13	2.7	2a	1	2.0	3a
13	1.9	4a	1	2.5	3a
1½ inch	4.5	6			

REFERENCES

- ¹ U. S. Pat. 1,620,337.
- ² U. S. Pat. 1,967,836.
- ³ U. S. Pat. 583,336.
- ⁴ Brit. Pat. 157,040.
- ⁵ U. S. Pat. 1,786,916.

DISCUSSION

MR. TOWNSLEY: You stated that probably the reason for wanting a narrow angle for motion picture work was perspective. For 8-mm and 16-mm equipment particularly, is it not probably true that one of the major considerations is the necessity for getting the shutter and aperture plate between the back of the lens and the film, for normal construction?

MR. KINGSLAKE: The back focus must also be considered, but I imagine that

this field-angle was determined before the 16-mm Cine camera came into the picture at all. The small angle was used in the early days when back focus was not a problem and the 8- and 16-mm designers desired to retain that small field. If a wider field-angle were demanded, high speed would become difficult, which fact alone would force us to use the smaller field, even if other considerations had not come in first.

MR. MITCHELL: In the early days of 16-mm film one of the principal points made when the one-inch lens was used, which was standard equipment; was that the lens would give the equivalent perspective of the two-inch lens used for the standard 35-mm film in the Hollywood studios.

MR. KELLOGG: Referring to the device consisting of a positive and a negative lens, which can be put in front of the camera to enlarge the field or give a wide-angle effect, it appeared in the diagram you showed that if parallel light enters either lens it issues from the other as parallel light. When this condition is fulfilled, is it not true that the system is reversible provided both lenses are of adequate diameter, thus serving as either a wide-angle attachment or as a telephoto attachment?

MR. KINGSLAKE: You can reverse them, but mechanical considerations are the usual limitation. Some lenses are mounted a long way down the cell, and it is necessary to push the back lens of the attachment close to the camera lens, so that you would need specially mounted camera lenses to accommodate a reversible attachment. Moreover, the corrections which would have to be included would make an interchangeable attachment expensive, and it would be cheaper to have two lenses than one, although it would of course be more convenient to have one. In ordinary cameras there is enough room and you could turn the lens around from front to back quite easily.

MR. ROGER: Have experiments been made with regard to the optimum in sharpness, first, with the mechanism still, and, second, with the mechanism operating normally? Since in a motion picture camera, with its gears and intermittent motion, a slight vibration may be felt in one's hand, this vibration might perhaps be transmitted to the lens and so cause lack of sharpness on the film, however slight.

MR. KINGSLAKE: That is true, but ordinarily Cine lenses are manufactured and treated with exactly the same procedure as for ordinary lenses. They are tested first on a lens-testing bench, and they are tested also for motion pictures, and comparisons made very carefully. The lens taken by itself without any film at all should give as good an image as a camera lens gives.

MR. MAURER: One of the defects I have occasionally encountered in 16-mm photography is the tendency of the reflections from the internal surfaces of a lens to form a round image in the center of the picture, possibly an image of the front of the lens hood, which makes a bright flare spot in the picture. This occurs with a number of widely used lens types. Can you tell us whether modern lens designers have been making any attempt to expand the utility of the type of lens that is represented by the well known Dagor and Protar types, in which the components of the two sections of the lens are all cemented together, thus cutting down the number of reflecting surfaces. Most lenses of those types have been pretty slow, but if I am not mistaken there was one made in England that was pushed up to an aperture of $f/4$. It would seem as though, with further development, that type of lens might become extremely useful.

MR. KINGSLAKE: That is true. You can make those types up to $f/4$. In the original Dagor design the contact surface inside has almost reached the hemisphere at $f/4$, and the only way you can improve it would be to use high index flints and low index crowns, but the result would not be very satisfactory.

The residual zonal aberrations are very large in that type, whereas they are very small in the Petzval type, which is why that type has been used for the higher apertures. The question of a flare spot is usually attributed to an image of the iris formed by reflexes in the back member of the lens. The flare spot appears only at very small stops— $f/16$ or $f/22$ —and in many types it seems to be practically unavoidable. On the other hand, other types of lenses do not have a flare spot. A notable case is the Sonnar, which has recently been introduced by Zeiss. The back part of that is a cemented triplet, and it behaves like the Dagor type in not forming a flare spot. The problem is a very live one to lens designers, but it seems extremely hard to avoid it, although by chance we may land on a lens which is good otherwise and does not have a flare spot. Ordinarily the flare spot is considered of secondary importance. It can be avoided by not taking a photograph of a dark subject against a bright background. If you take a photograph of a person in the middle of a picture, in front of a window, for example, the flare spot may be quite marked; but if you take care that there is not a bright glare of light on the outside of the picture and a dark center, the flare spot ordinarily is not serious.

MR. BRADY: Assuming that we can eliminate the intermittent movement, what advantage would that be to you as a lensmaker?

MR. KINGSLAKE: I do not believe it would make any difference. We merely consider the lens as covering the full field of the picture.

MR. BRADY: Would eliminating a rear or front shutter help?

MR. KINGSLAKE: Sometimes not having a rear shutter would have a slight advantage. That would, however, not be ordinarily important except in Cine 8 cameras where the back focus is getting very small.

MR. FAMULENER: Has work been done in applying to lenses some of the non-reflecting wax coatings that have recently been worked out?

MR. KINGSLAKE: That has been tried a good many times, but there is always the question of getting at the surface. I imagine you could put the wax layer on the inside of a lens with great ease, but how long it would stay there, I do not know. One would not like to sell lenses with such an unstable coating on them as that.

MR. WALKER: What is the difference between a lens which is corrected for color and one which is not?

MR. KINGSLAKE: All lenses today are corrected for color by the use of more than one kind of glass in the lens. Achromatism was introduced 150 years ago. You could not sell a lens today in which the color was uncorrected.

MR. FLORY: It has been my experience that in both taking and projecting 16-mm motion pictures, the quality of the taking lens is far superior to that of the projector lens. Is that true?

MR. KINGSLAKE: In what respect?

MR. FLORY: Flatness of field on the screen, for example. Sixteen-mm projector lenses are made to sell for a low price, and I have not been able to buy a lens which satisfies me. The cost of most of the projector lenses runs from \$20 to \$25, and I think some work should be done on manufacturing projector lenses

that are more comparable, so far as quality goes, to the camera lenses. We will spend \$100 for a camera lens, and then buy a projector lens which is relatively inexpensive, as a result of which, it seems to me, we lose a great deal of the quality in projecting after we have gone to a great deal of trouble in producing a good negative and print.

MR. KINGSLAKE: That is true. Most projection lenses are of the simple type which has a field of only about 5 degrees. The solution is to put on a field flattener, and many of the better projectors are now equipped with such field flatteners. I agree that it seems poor economy to have a cheap lens on a good projector. Probably in time to come field flatteners will be supplied on all projectors as a matter of course; indeed, I imagine the public will demand it.

MR. PALMER: Can we assume that with a lens that is corrected for color the visual focus and chemical focus are both in the same plane?

MR. KINGSLAKE: That is usually an entirely safe assumption. Sometimes lenses get by through carelessness in design or accidents in manufacture, in which there is a slight difference between visual and photographic focus, but the aim is always to eliminate that small difference. On the other hand, it seems impossible to bring all the colors to a common focus. The best you can do is to bend the spectrum around so that the blue and yellow coincide, and let the other colors take care of themselves. Ordinarily, that is quite a safe compromise. Sometimes the blue is bent around too far and falls beyond the red, and then you get a little chemical focus; or it may be a little under corrected, in which case the blue coincides with the green, and the red is too long. If you do find a difference, it is generally either accident in manufacture or carelessness in design.

MR. FRITTS: In judging quality it is well to note the different conditions under which cameras and projectors are operated. I believe Mr. Kingslake's paper presupposes a flat film in each case, but with increase in light in the projection beam it becomes increasingly difficult to hold the film flat. Perhaps the difference between projection quality and camera quality might hinge upon that point, rather than upon any consideration of the lens itself.

MR. ROGER: In still photography, one uses special apochromatic lenses, especially in the graphic fields, for color reproduction. They use apochromatic lenses for getting the best color results. Are apochromatic lenses also available for motion pictures and 16-mm motion picture photography?

MR. KINGSLAKE: The name "apochromatic" is very unfortunate. It was originally applied to microscope objectives, in which an attempt was made to bring three colors to a common focus. In motion pictures, some lenses are available in which the residual color differences have been considerably reduced, and such may sometimes have been called "apochromatic." The so-called apochromatic process lens is surprisingly well corrected in this respect, but more especially in respect to the equality of picture size in all colors. The name "apochromatic" has often been used merely as a sales point.

REPORT OF THE STANDARDS COMMITTEE*

Summary.—Proposals have been received from the ISA Secretariat for International Standardization of raw-film cores; 16-mm sound-film; projection reels; projection reel boxes; 8-mm film dimensions; and definition and marking of safety film.

Most of these proposals differ from the SMPE standards only in tolerance. Some of the tolerances appear to be unimportant and some important. The European practice for projection reels differs so widely from the American practice that it is deemed impossible to come to an international agreement. Standardization of 16-mm projection reel boxes appears to be outside the range of useful standardization.

The international standard definition of safety film has been cleared up in all points except the question of nitrogen content.

The question of sound-track dimensions for 35-mm and 16-mm film was clarified, to a considerable extent, at the Hollywood meeting of the Committee but no definite conclusions have yet been reached.

No satisfactory standard for 16-mm sound-film sprockets has yet been attained.

The work of the Standards Committee, since the last meeting, may be divided into four classes:

INTERNATIONAL STANDARDS

An attempt has been made to come to an agreement with the German Secretariat of the International Standards Association and to bring their proposed standards and the American standards in line. In nearly all cases the differences are minor ones involving tolerances. Our last reply to their proposal was sent shortly before the war began, and it appears likely that further developments in the industry will modify the standards or tolerances before there can be any hope of an international agreement in these matters.

AMERICAN STANDARDS

We have prepared our standards for submission to the American Standards Association and adoption by them as American standards. In most cases, this has meant solely a change in form rather than any change in the actual standards themselves. The American

* Presented at the 1939 Fall Meeting at New York, N. Y.; received October 12, 1939.

Standards Association objects to any reference in their publication to the organization sponsoring these standards, and this has resulted in considerable editing of our standards drawings.

REVISION OF OLD STANDARDS

(a) *Sound-Track Dimensions.*—The most important revision of old standards is the work on sound-track dimensions being carried on largely by the Academy of Motion Picture Arts and Sciences. It will be remembered that about a year and a half ago a proposal was made to increase the width of the variable-area sound-track at 100 per cent modulation from 0.071 to 0.076 inch. There were serious objections to this proposal, and a Committee of the Academy has been working for some time, attempting to reconcile the various difficulties with one another. One proposal, which at present seems to take care of many of the difficulties, is to use the width of 0.071 inch for 100 per cent modulation, and to specify a maximum width of 0.076 inch for the sound-track. This maximum width would be fixed by whatever mechanical features are involved in the sound equipment, so that, in cases of overrunning the 100 per cent width, no distortion would occur up to 0.076 inch provided no further errors were introduced in the printing or projection. This practice appears to be the actual practice in use at the present time in the majority of cases. The question of the separation between the two halves of the push-pull sound-track has not yet been satisfactorily determined, although the prevailing practice still appears to be to allow 0.006 inch.

The standardization of 16-mm sound-track dimensions should be based on those for 35-mm, and this revision is also awaiting the work on 35-mm sound-film standards.

Definition of Safety Film.—The question of a standard definition of safety film has, in the past, been very much of an international question, and probably no satisfactory agreement will be obtained until the end of the war. Although we are recommending to the American Standards Association our old standard method of determining burning time, we are in practical agreement with the European countries in regard to a new method of determining burning time and defining safety film, except that we are still not in agreement as to whether or not a limit should be placed upon the cellulose nitrate content of safety film. The international recommendation is that this limit should be placed at a figure corresponding to 0.36 per cent nitrogen, whereas some in this country maintain that no specification

PROPOSED STANDARD FOR 16-MM RAW STNCK CORES

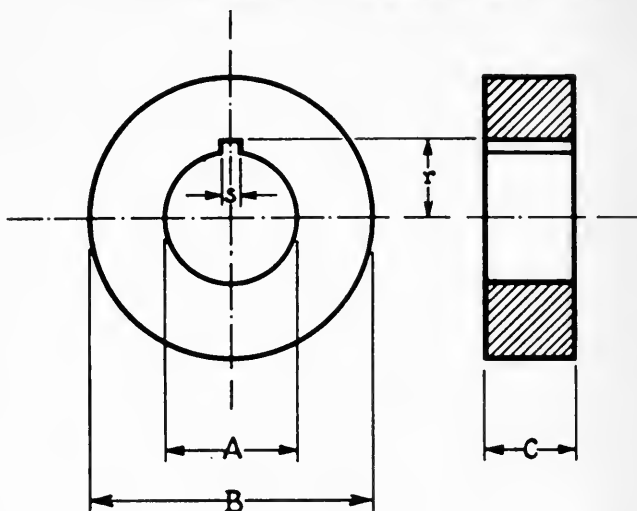

	Millimeters	Inch Equivalents
A	25.90 ± 0.20	1.020 ± 0.008
B	50.00 ± 0.25	1.968 ± 0.010
C	15.50 ± 0.50	0.610 ± 0.020
<i>Recommended Practice</i>		
r	16.70 ± 0.30	0.657 ± 0.012
s	4.00 ± 0.20	0.157 ± 0.008

Bore A to fit freely to Hub 25.40 ± 0.1 mm or 1.000 ± 0.004 inch diameter.

should be drawn on the analysis of the film base, but should be drawn solely on its performance.

NEW STANDARDS

16-Mm Sound Sprockets.—The question of standards for 16-mm sound sprockets is still under consideration. Some of the manufacturers of projectors maintain that the design of the sound sprockets depends so much on the design of the rest of the projector that there is very little that can be usefully standardized.

Reduction Ratio for 16-Mm Reduction Prints.—This also depends somewhat on the 35-mm sound standards and is awaiting that standard.

Future Work.—At the last meeting of the Standards Committee several items were brought up that appeared to warrant future investigation. These are:

- (1) A standard method of rating loud speakers.
- (2) A standard method of measuring flutter.
- (3) A standard method of rating amplifiers.
- (4) A standard method of measuring auditorium acoustics.
- (5) A revision and elaboration of our glossary of technical terms.
- (6) A standard method of measuring screen brightness.

After initial approval by the Committee, a letter ballot was recently taken of the entire Standards Committee on the Projection Room Plans prepared by the SMPE Projection Practice Committee, and the raw-stock core specifications prepared by the SMPE Standards Committee. The Projection Room Plans were published in the JOURNAL of the Society, November, 1938. The other project is reproduced herewith.

Having received unanimous approval of the two projects by the letter-ballot of the Standards Committee, publication of the fact is made hereby. If within sixty days of publication of this issue of the JOURNAL, no objections to these proposals arise from the industry, the proposals will be transmitted to the Board of Governors for validation as SMPE Standards, after which they will be transmitted to the Sectional Committee on Motion Pictures of the American Standards Association.

E. K. CARVER, *Chairman*

P. H. ARNOLD	C. L. FARRAND	T. NAGASE
F. C. BADGLEY	G. FRIEDL, JR.	N. F. OAKLEY
M. C. BATSEL	H. GRIFFIN	G. F. RACKETT
L. N. BUSCH	A. C. HARDY	W. B. RAYTON
A. COTTET	L. B. HOFFMAN	C. N. REIFSTECK
L. W. DAVEE	R. C. HUBBARD	H. RUBIN
A. C. DOWNES	E. HUSE	O. SANDVIK
J. A. DUBRAY	C. L. LOOTENS	J. L. SPENCE
P. H. EVANS	K. F. MORGAN	J. VAN BREUKELLEN
R. E. FARNHAM		I. D. WRATTEN

DISCUSSION

MR. CRABTREE: With regard to the glossary, why not take a vote and let the majority decide whether they want to include all terms, or restrict the glossary to the "highbrow" terms? The Nomenclature Committee could split up its report in two parts, dealing with the "slang" terms in an appendix. A glossary is useless unless it describes what a "wow" is, for example.

MR. OFFENHAUSER: In the committee meetings that question was discussed, and a term about which much discussion arose was the word "jeep." A "jeep" is well understood by television engineers, but has not yet been adopted by motion picture engineers. Should we include the glossary such a term as "jeep"?

MR. CRABTREE: I would hold that term in abeyance for a while; but there are many other terms that have come into common use and are not in our glossary.

MR. ROSS: The non-technical expressions might be added to the definitions of the technical terms. For example, the word "bloop" should be included as a non-technical term, and the laboratory equivalent stated also.

MR. WILLIFORD: My feeling is much the same as Mr. Crabtree's. When we do not know what people are talking about, we go to a glossary, expecting to find there the things we do not know. Whether we like the use of slang in our industry or not, it is here; and when the people who use a thing give it a name, that is the name the thing is going to be known by. I could give you one or two classic examples of companies trying to get the public to stop calling things by names the companies did not want them known by, and spending a lot of money to get new names accepted, but it could not be done. So if it is a "jeep" in the television industry, it is probably going to be a "jeep" in ours. The discussion we are having here ought to be of some help to the Committee in determining their policy, but I do not believe, as a point of order, we ought to vote on it, although everyone who has an opinion on it ought to express it.

MR. KELLOGG: It would be helpful if we could standardize our definition of "wow" or "flutter"—not the word but the thing itself. Measurements of speed variation may be metered in either of two ways. It is very common to use a meter which will measure the rms deviation from an average speed. It is also very valuable, for finding out what is the matter with a machine, to make an oscillogram showing from instant to instant what the speed has been. That will show whether it has been consistently above or below the normal speed, as well as the fluctuations. We have used a "wow-meter" of the oscillograph type for most of our studies in Camden, but on the West Coast it has been the general practice to use the rms type of flutter-meter. Some confusion is likely to result in reporting the performance of the various machines tested. The oscillogram does not give a ready indication of rms deviations, but has been used for showing the overall change from minimum to maximum speed, in a period of about six seconds. Clarifying definitions of wow and flutter would be a valuable service. I suggest that the term "rms flutter" be employed to designate the flutter as measured on an rms type of meter, while "overall wow" or "overall flutter" be used to designate the extreme fluctuations. The overall wow is usually from four to six times as large as the rms flutter. Even if the speed changes were a pure sine wave, the overall value would be 2.8 times as large as the rms value.

MR. IVES: If the Committee finds it impracticable to attach its authority to the definitions within a reasonable time for members to make use of such a new edition of the glossary, might not the term be published as being under the consideration of the Committee, with such connotations as have been suggested by responsible persons familiar with the particular branch of the field wherein the terms are used frequently? The terms will then be available in the JOURNAL, even if they do not have the backing or full authority of the Committee.

MR. OFFENHAUSER: The difficulty with a procedure of that sort is that the

average reader will glance at the first few terms of the glossary and then start looking at the next article. It will be difficult to get each of the members who would be concerned particularly with the glossary to take an interest in it at the time it is printed.

MR. MORGAN: Perhaps a questionnaire would be more effective than using the JOURNAL.

DR. CARVER: That is what we had intended to do—to send parts of the glossary to those who were especially interested, with a questionnaire.

MR. DAVEE: It seems to me that a word like "jeep" is a little far-fetched. The word "wow" conveys some idea to us; but the word "jeep," as I understand it, means a complete television transmitter and receiver in practically one unit. Now, if "jeep" conveys anything as far as that particular adaptation is concerned, I can not see it. Such words should be left out of our glossary, and maybe a word better adapted to the meaning should be substituted. We should not let the industry go "haywire" on these terms.

MR. ROSS: Most of these terms apparently originate in the studios. Perhaps in sending out this questionnaire it might be well to ask the studios to add any new terms they have recently concocted. It might be well to split the terms into groups, each applying to its particular branch of the industry. This will reduce the number of terms for each branch to consider after receiving the questionnaire and therefore insure more prompt reply. Also, in addition to a dictionary arrangement of all the terms, it might be well to list the terms according to the various branches of the industry.

MR. MORGAN: I suggest, in addition to sending the questionnaire to individuals, that it be sent to the various department heads, such as the sound laboratory and camera departments. If they could not find the time to do it themselves, they would probably delegate someone to prepare the answers.

MR. ROBERTS: Has the Committee considered standards of tolerance for sound-track placement?

DR. CARVER: Standards of tolerance for sound-track placement were in the old standards, and are in the proposed standards. The tolerance is 0.003 inch.

MR. ROBERTS: I understand that the Academy has considered a 2-mil standard.

DR. CARVER: The Academy is doing quite a lot of work on the problem, and we have appointed a sub-committee on the same subject. Mr. Davee is the Chairman.

MR. ROBERTS: I am quite sure that they are working toward ± 2 mils, but I do not like to see that standard at present. The Academy proposes to give quite a bit of tolerance to projector scanning-beam width and to projector film-path misalignment. These two projector tolerances will be larger than the combined tolerance of negative and print. In a print it will be necessary to squeeze the combined misalignment of negative and print into ± 0.002 inch. In the case of processes where dupes are made photographically, a recorder misalignment and three printing machine misalignments were all added together. These three can be kept to 0.003 but are extremely difficult to keep within ± 0.002 inch.

DR. CARVER: I think the answer to the tolerance question will have to come through a consideration of what the laboratories can maintain. With your new instrument they probably can do a lot better job in the future, and therefore the tolerance might be cut down.

REPORT OF THE STUDIO LIGHTING COMMITTEE*

Summary.—An indication is given of the quantity of illumination used on interior motion picture sets together with the technic of "key-lighting." Key-lighting levels in common use are stated and some of the variables in light balance are mentioned.

A photographic technic, previously described,¹ utilizing the photoelectric cell meter and the so-called system of "key-lighting" is rapidly gaining in popularity in the West Coast studios.

The key-light or illumination falling upon the immediate foreground, particularly upon the faces of the dramatically important characters, is used as a middle-range basis upon which to balance the shadow and highlight areas of the set. This key-light is established visually by the cinematographer and checked with a photoelectric cell meter.

Such a procedure, if followed correctly, produces a negative with the key-light exposure density midway between the underexposure and overexposure portions of the gamma curve, and therefore allows the greatest latitude for balance without blocked out shadows and burned up highlights. It also allows the laboratory to process the negative under time-and-temperature conditions with a reasonable assurance that the negative will print within a narrow range of printer lights.

In black-and-white photography no attempt is made to check the highlight and shadow areas with a meter. As the use of the meter becomes more common the shadow, key-light, and highlight areas may all be checked as a precautionary measure, but at present it is thought that the single measurement of key-light is sufficient to enable the cinematographer to establish the balance so there will be detail in both shadow and highlight areas if he wants it there.

Certainly, on a new type of film, the H&D curve of the emulsion should be checked for latitude, and meter readings taken of shadow and highlight areas to determine whether or not the exposure lies

* Presented at the 1939 Fall Meeting at New York, N. Y.; received October 6, 1939.

within the straight-line portion of the gamma curve, in order to maintain density within the limits of correct exposure.

The key-light levels on black-and-white sets, with the exception of extreme effects, range between 75 and 150 foot-candles, depending upon the lens aperture used, the individual technic of production, and the laboratory processing methods of the various studios.

However, in analyzing data on set lighting, emphasis should be placed upon the fact that the key-light level is only an indication



FIG. 1. Black-and-white: key-light level, 140 foot-candles.
(Courtesy Paramount Pictures, Inc.)

of the total illumination used. Measurement of the key-light is usually made with the meter held close beside the subject and the light-sensitive cell pointed at the key-light source and receiving the rays that would normally fall upon the face of the subject. Considerable judgment is exercised in the exact positioning of the light-sensitive cell.

If there is little photographic contrast between the character's costume and the walls of the set it may be necessary to interpose backlight from the parallels of the set, between the character and the walls, of the order of from two to three times the intensity of the key-light level to create the illusion of depth. Shafts of light,

such as sunlight and shadow effects, require several times the intensity of the key-light. Also, certain types of sets call for high levels of illumination while others are dark and dreary although the key-light may be the same.

In Technicolor, or any color process, the addition of color precludes the practicability of direct quantitative comparison between the total illumination used on a color set and a black-and-white set. The key-light levels used with Technicolor vary from 150 to 400 foot-



FIG. 2. Technicolor: key-light level, 300 foot-candles; left side highlight, 500 foot-candles; right side light, 250 foot-candles. (Courtesy Paramount Pictures, Inc.)

candles, and sometimes higher, yet the total light on a Technicolor set with a key-light level of 400 foot-candles can not be compared directly with a black-and-white set with 150 foot-candles key-light level because it may not be necessary in the case of color to separate the characters from the background with a wall of intense light.

Also, in black-and-white photography, the exact shade of gray in which a costume is rendered is of relatively small importance, whereas in color pictures the total effect is enhanced by the faithfulness of reproduction of the original costume.

As an example, a deep green velvet dress with many folds may

photograph dark gray in black-and-white photography and the shadow areas may be totally dark, but the effect may be acceptable. In color, however, it is necessary to illuminate the shadows so the final print will reveal a green dress with green, rather than black, folds.

In dealing with black and white, where the absence of light means black, it is often possible to ignore deep shadow areas without attracting the attention of the casual observer. But in color, where the absence of light also means black, it is essential that the shadow areas



FIG. 3. Showing position of photoelectric cell meter in obtaining key-light; Cinematographer Victor Milner. (Courtesy Paramount Pictures, Inc.)

be illuminated with sufficient intensity to give at least a suggestion of their true color.

C. W. HANDLEY, *Chairman*

G. F. RACKETT

R. E. FARNHAM

V. E. MILLER

E. HUSE

E. C. RICHARDSON

J. H. KURLANDER

REFERENCE

¹ CLARK, D. B.: "Methods of Using and Coördinating Photoelectric Exposure-Meters at The 20th Century-Fox Studio," *J. Soc. Mot. Pict. Eng.*, XXXIII (Aug., 1939), p. 185.

THE IMPORTANCE OF COÖPERATION BETWEEN STORY CONSTRUCTION AND SOUND TO ACHIEVE A NEW PERSONALITY IN PICTURES*

LOREN L. RYDER**

Summary.—Working toward closer coördination between the creative and technical groups in the making of motion pictures the author points out the objective and factors essential to good motion picture entertainment. Subsequently to the analysis of the general problem, examples are given illustrating the types of problems where technical knowledge can assist in obtaining a better dramatic result.

The information presented in this paper has been taken from a paper which the writer prepared at the request of the Paramount administration for presentation to the producers, directors, and writers of our company. The thought is that too large a gap exists between the creative and technical groups, and that this and other discussions of the overlapping problems between our creative and technical groups will make for better motion picture entertainment.

The producers, directors, and writers were asked to consider the problem from the standpoint of the technician and in this case I am going to ask you to consider the problem from the standpoint of a producer or studio executive. Your job is to create entertainment. *Let's stop and analyze the problem.* Motion pictures are a means of expression. As defined in the Britannica it is a means of "transmitting emotional stimuli and experience by re-creating events." It is the conveyance of an illusion to the audience.

For the most part we are letting our audience "listen in" on the intimate lifelike happenings of our characters. But, at times we want our audience to feel that they are a part of the dramatic story which is being told, as for example, the earthquake in the picture *San Francisco*. Good motion picture entertainment takes the attention of the audience from their thought of every-day activity, and even away from a realization that they are in a theater. Then after so captivating the interest of the audience we carry them around from place to

* Presented at the 1939 Fall Meeting at New York, N. Y.; received October 12, 1939.

** Paramount Studios, Hollywood, Calif.

place, play on their emotions with music, give them realism with effects, and swing them into a climaxing end title.

Most of our effort in the past has been toward technical improvements many of which have heightened the entertainment value of our pictures. But we are approaching a point where the technical status of our work is ahead of our dramatic usage of technical knowledge and devices.

In sound, just as in pictures, we have never reached that success of complete illusion, and, we ask ourselves, *Why?* Naturally, we realize that our means of expression is at the moment limited by a flat screen for the picture and a point source back of the screen for the origin of sound. In attempting to use this limited means of expression, we in the motion picture industry have worked out a technic which motion picture audiences have learned to accept. But, is this the best set-up and are these the best technics? And the answer is—only if it gives the best illusion and the best entertainment.

My objective is not to revolutionize this business, but to point out more definitely our objective, the objective of the producers and the studio executives and the types of problems where technical knowledge can assist in obtaining a better dramatic result. We will start by considering certain of the problems for which we have no direct and complete answer.

Much of the illusion of intimacy is lost in our dramatic and love scenes. Pictorially we bring our characters closer to the audience by using closer shots, but from the standpoint of sound we find ourselves compromising. Increased levels play against the illusion of intimacy. And, if we reduce the volume appreciably, the sound will feel artificial against the large picture. In shooting the scenes our microphone is placed close for an intimate pick-up, we use "effort equalization"¹ or the equivalent, but the audience distance from the screen plus the theater reverberation prevent accomplishment of the desired effect. What we want is the effect of the actor speaking low but close to the listener—the effect obtainable when you are seated close to your radio.

I will avoid a discussion on theater acoustics and speaker equipment, but some day someone will supply the answer; it may be as simple as a new speaker system directional at all frequencies and directed at the audience, thus minimizing the distant effect caused by reverberation. Meanwhile, producers, directors, and writers are limited in the scope of story construction by our inability to remove such obstacles and our means of coöperation (as technicians) should

be by recognizing these problems and finding ways of meeting them.

Shouts and high-volume commands frequently lose their force and become thin and undramatic as reproduced in the theater. This may be partly caused by the dialog bass suppression used in the recording channels. (The bass suppression is usually set for normal dialog, which is incorrect for a shout.) But we are safe in saying that most of this trouble is caused by overload either in the recording system or in the theater reproduction.

We encounter still another problem when we consider dynamic expression. Our technic evolved from practice indicates a necessity of playing normal dialog at an increased level to the listener as compared to the sound level at the point of pick-up. The volume levels at which sounds become objectionable to the listener have not been changed, so by this practice we have reduced our permissible range of expression as compared to normal life. The result is less effective entertainment and the problem will probably not be answered until steps are taken to reduce our normal dialog playing levels in the theaters.

We should ask also what is the level at which sound becomes objectionable to the listener? To this I can positively say that the limit of desirable volume in most theaters is dependent upon the power-carrying capacity of the reproducing equipment. Overload changes sounds of rounded true tonality into a conglomeration of harsh, piercing, and unpleasant sounds. Our organization has made many comparisons and our executives have observed the difference in audience reactions and acceptance of spectacle sequences. In theaters with ample power the effects seem real and dynamic, while in houses equipped with insufficient power the effect of the sequence is lost and the sound seems objectionably high even though the acoustical energy has been reduced by the over load.

Volume range is also limited in the downward direction by noise, but to this end we are making progress as reported in Dr. J. G. Frayne's paper "Report of Progress on Adaptation of Fine-Grain Film to Variable-Density Sound Technic"² and Dr. C. R. Daily's paper "Improvement in Sound and Picture Release Through the Use of Fine-Grain Film."² In this regard there are some observations worthy of note. At the preview of *Geronimo*—(the first picture "movietoned" and shown to an audience on fine-grain film) the audience did not analyze, and probably most of them did not notice the reduction in film background noise, but their reactions, especially

the complete quiet of the audience during dramatic sequences, was evidence enough for the studio executives. The writer and all those present were convinced of the value of reducing noise, especially noise from the screen.

It is important to note that sound has progressed to the point where improvements are no longer evaluated by direct audience criticism or comment but none the less surely by the audience reaction.

Music is a most important factor in screen expression but few persons realize the complexity of technics in music handling in conjunction with picture shooting. In a recent study we found seventy-eight different combinations for handling music involving pre-scoring, separate vocal and orchestra recording, direct recording, cueing, playing back, and post recording. In fact, at times so much thought is given to the mechanics of tying musical recording into the picture shooting that the musical objective is forgotten. Music is used for creating an emotion within the audience, as in an under-score; giving a complete concert rendition as the Damrosch number in *Star Maker*, establishing tempo in a dance sequence, punctuating action, or "plugging" a number with the hope of making a hit tune.

There are many problems and shortcomings in meeting these demands. For instance, in a tap-dance routine, the music is usually recorded first, a "pre-score," so as to establish a tempo guide which can be played back or reproduced on the production stage and used as a guide for shooting all the scenes and angles of the sequences in their various camera angles. If the "playback" is reproduced low so as to obtain a good recording of the taps, our dancer has trouble keeping in step with the music or in any case his action tends to drop with the music level and we do not obtain the desired punch for the scene. If, on the other hand, we "play back" at a higher level we either override the taps with music or in any case pick up too much of the "playback" music for subsequent handling in dubbing. Frequently we "post-score" the taps to pictures and guide track subsequent to editing of the picture and the result is an out-of-sync, none-too-realistic sequence. The same general problem is encountered in much of our vocal work and I know you have all seen and heard good scenes and good music made unconvincing because of poor synchronization. A solution might be a directional speaker and a directional microphone arranged so as not to work into one another or possibly a phasing device to cancel the picked-up noise of the music playback.

Still striving toward our objective of better entertainment we can find more problems affecting our re-recording or dubbing, our processing and our release, but these are all problems based on our present procedure.

Sound has in a way built a fence around itself. Our past limitations are being used by the entertainment creators as a guide of future possibilities. They, the creators, have no way of expanding the scope of picture entertainment unless our vision reaches out, obtains the tool, and presents them to the creators for incorporation in a picture. We should study all forms of entertainment and borrow, if you please, any technic or equipment set-up which will aid in picture entertainment.

We are not without recent developments of this type. The Bell Laboratories have presented the vocoder and Gilbert Wright of Hollywood has demonstrated a new re-modulating device.

Showmanship is a peculiar business and our audiences are frequently hard to entertain, but there is one thing certain and that is that audiences enjoy something new, something different. They always react to things that they have never seen or heard before.

REFERENCES

¹ MORGAN, K. F., AND LOYE, D. P.: "Sound Picture Recording and Reproducing Characteristics," *J. Soc. Mot. Pict. Eng.*, **XXXIII** (July, 1939), p. 107.

² Pp. 3 and 12, this issue of the JOURNAL.

NEW MOTION PICTURE APPARATUS

During the Conventions of the Society, symposiums on new motion picture apparatus are held, in which various manufacturers of equipment describe and demonstrate their new products and developments. Some of this equipment is described in the following pages; the remainder will be published in subsequent issues of the Journal.

A MULTIDUTY MOTOR SYSTEM*

A. L. HOLCOMB**

Present-day sound recording for motion pictures generally takes place under one of the following conditions:

- (1) Original recording on a studio stage.
- (2) Original recording on location.
- (3) Re-recording.
- (4) Background projection.

Up to the present time no one motor system has been designed which will operate satisfactorily under all these circumstances. The synchronous motor system is convenient on studio stages but requires an accurately regulated a-c supply which is often not available on location. The d-c interlock system provides adequate portability for location work but requires the use of portable storage-batteries which are undesirable on the stage. Neither of these two systems provides interlock from start and, therefore, can not be used for re-recording or background projection for which an a-c interlock or Selsyn system must be used.

The new multiduty motor system not only provides a single system for all these purposes but also better operation in its various applications. One of the first features to appeal to the studio sound and camera departments is that the same motor can be used on the camera whether shooting at the studio or on location. The same is true of portable recorders which may be used either in the studio or on location without change of motors or operating technic. At the same time the new system provides more power for camera motors without increase in size, more accurate interlock, and a considerable number of accessory features which add materially to the convenience and reliability of operation.

Multiduty Motors.—The basis of the new system is the development of a new type of motor which is capable of operating satisfactorily on either a-c or d-c power supply. In Fig. 1 it will be noted that the multiduty motors are basically

* Presented at the 1939 Fall Meeting at New York, N. Y.; received October 12, 1939.

** Electrical Research Products, Inc., Hollywood, Calif.

d-c motors with the commutators tapped for 3-phase interlock as used in previous d-c interlock systems. D-c power, in this case from a common 96-volt battery or generator, supplies field and armature current for each motor. When power is applied to the individual motors they each start as d-c shunt-wound machines. As soon as d-c is applied to the armature, a voltage appears at the slip-rings which becomes an alternating three-phase potential as the motor rotates and provides the necessary interlock power. A relatively large amount of short-circuited damper copper is distributed through the d-c field structure in such a form as to provide a squirrel-cage winding.

When these motors operate in a d-c interlock system a difficulty occurring in some previous systems, due to short-circuiting through the interlock windings when the motors are out of phase, has been overcome by including ballast resistors in series with the interlock connections. These resistors have relatively low resistance when cold but increase to roughly 12 times this resistance when called on to carry short-circuit current. In operation the motors, when in phase with each other, interchange relatively little current, and the resistors, being cold, are

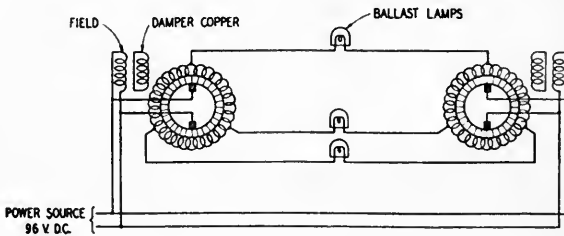

FIG. 1. Multiduty motor system.

of low impedance. Under a short-circuit, however, this resistance builds up with sufficient rapidity to protect the motors against destructive current interchange.

Another desirable feature of the ballast-lamp resistors is that they provide a pilot indication of interlock condition, showing an increasing glow as the motors tend to pull apart, which becomes a bright flickering when the motors actually pull out of phase. This permits the operator to adjust the normal speed of each motor quickly and with sufficient accuracy to bring an out-of-line motor into step at the beginning of a take, while under previous methods of operation it was necessary to stop the take and recheck motor speeds independently.

The motors when operating as d-c units are essentially d-c motors, delivering mechanical power to the shaft, and inverted converters delivering any necessary power to the interlock circuit. When operating from a 96-volt d-c power supply the camera motor produces approximately 300 mechanical watts and operates at about 50 per cent efficiency.

Fig. 2 shows another totally different method of operation which requires no change in the motors. In this mode three-phase alternating-current is supplied to the rotor through the slip-rings which were used for interlock when operating on d-c. No ballast-resistors are necessary in the three-phase connections between rotors since the d-c supply to each motor has been opened. The winding

which has been functioning as a d-c armature now becomes, in effect, a three-phase delta-connected winding, and when power is supplied to this winding, it reacts with the damper copper distributed through the pole-pieces and provides induction motor torque sufficient to start the motor and bring it close to synchronous speed in the same manner as that employed with the induction-synchronous motor. The motor will pull into synchronism in much the same way because of the salient poles which are in the stator in this case instead of in the rotor as in the usual synchronous motor.

The amount of copper which it is possible to dispose throughout the stator while still maintaining adequate space for the d-c field winding is not enough to provide sufficient power for a camera motor without increasing the size beyond desirable bounds. However, it has been found that by proper poling of the d-c field windings they can be made to assist the induced poles of the squirrel-cage or damper winding if the field winding is self-excited from its own commutator. This assistance can be made to provide somewhat more than twice the total

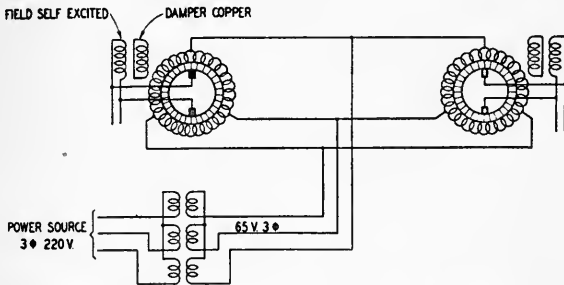

FIG. 2. Method of operation requiring no change in the motors.

power available from the squirrel-cage. Thus in the camera motors of the multi-duty system, the squirrel-cage copper alone will synchronize approximately 85 watts of mechanical power with a normal applied voltage. The addition of the self-excited field windings increases this maximum pull-in to over 200 watts, which is somewhat greater than the power supplied by any camera motors now in the field except those designed for Technicolor cameras. An added advantage of the self-excitation is the fact that the power-factor of the primary or three-phase winding may be brought up to any desired value and this, in turn, means low copper losses and relatively high efficiency.

When operating from 65-volt, three-phase, 60-cycle supply these motors have an output of 200 watts with an efficiency of approximately 50 per cent. The a-c supply is usually obtained from a three-phase autotransformer associated with the central control unit.

A third mode of operation is shown in Fig. 3, which differs from the synchronous mode in two respects. The windings are not self-excited but are supplied from an external d-c source which permits them to be fully excited at standstill. The three-phase supply is from an inverted converter driven from 110 volts d-c instead of a supply-line as for synchronous operation. While running, the motors

are essentially synchronous motors as in Fig. 2, except that the speed may be varied by varying the speed of the inverter which supplies them. Thus the motors will run at any desired speed, depending on the speed of the control motor, from zero to considerably above normal. At zero speed the inverter is, of necessity, at a standstill and of course if full voltage is still applied to the d-c input to the inverter, the current and heating will become destructive. However, if the d-c voltage is reduced, either by tapping down on a supply-battery or introducing series resistance, this heating may be held within acceptable limits for short periods. At the same time sufficient voltage is provided on the three-phase leads to the driven motors to maintain adequate current in the rotor windings so that the motors still remain aligned with their externally excited fields. The required voltage is very much less at standstill because of the fact that the impedance of the motor windings at standstill is reduced to resistance only. Since the distribution of voltage applied to the three-phase windings is determined by the position

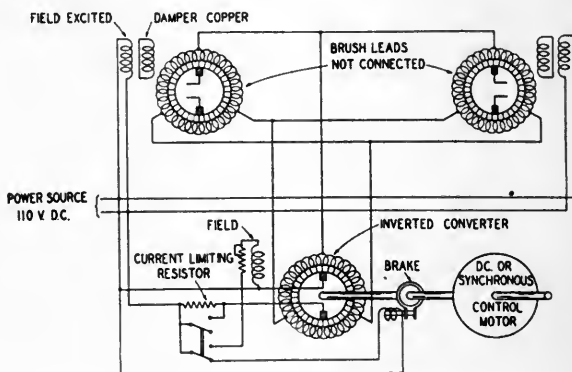

FIG. 3. A third mode of operation.

of the inverter rotor under its own brushes, the motors are effectively aligned with it and with each other at standstill and will come up to speed in the same alignment. A system utilizing this feature was used for some time at Universal Studio some years ago and proved the basic theory of operation to be sound.

This system has the disadvantage of requiring the inverter distributor which would seldom operate at as much as 50 per cent efficiency and which constitutes considerable weight in itself. With the increased batteries this system will weigh about four times as much as would a similar d-c interlock system without interlock from start. However, the new system is considerably lighter and less bulky than a Selsyn system.

The system outlined above is capable of operating in all three of the desired modes: d-c interlock for location work in which a high order of portability is desirable, synchronous for stage use, and interlock from start for special duties which may be required. In addition to the ability to operate in all the desired modes, these motors have the advantage of providing a coupling with each other, or with a supply-line, which is much tighter than any other system. This is due to the

fact that the motors have salient poles which are also excited by a d-c winding. The magnetic circuits are thus much more sharply defined than is possible with other types of synchronous or interlock motors. This rigidity of coupling can be measured by observing the position of a stroboscopic image while a motor is running "no load" and then applying some known percentage of the full load and observing the displacement of the image. Motors of various types can thus be compared provided shaft speeds are the same. The multiduty motors show about one-half the displacement of variable-reluctance synchronous motors and about one-fourth the displacement of the a-c interlock system. This factor is of chief importance in background projection where the phase relation of camera shutters to the projector shutter determines the exposure of the picture negative, and the new system should provide a considerable improvement for this duty.



FIG. 4. Portable control cabinet.

Other System Features.—With a type of motor available which is capable of all these modes of operation it was felt desirable to put them into operation in a manner which would serve the needs of the greatest number of producers. Consequently, with this in mind, a survey of the studios was conducted to determine the best method of adapting this system to their varied uses. As many as possible of the features desired by the studios have been incorporated in the auxiliary equipment described below.

A-c-D-c Control Cabinets.—Most of the studios desired some form of centralized control of all motors, whether they were operating on d-c or on a-c. This has been provided in the form of a portable control cabinet (Fig. 4) which serves for starting the motors and controlling their speed when operating on d-c, indicating the operation of the system, and other functions which will be described below.

Provision is made for connecting the various motors to the control circuits by means of standard six-conductor plugs, jacks, and cables. In order to provide the desired auxiliary features, it was found necessary to increase the number of conductors above the six required for actual motor operation. These auxiliary functions were combined in a second cable which was a standard six-conductor No. 18 speech cable, making it possible to utilize surplus microphone cables for this purpose. Provision is made for connections to three cameras and one film recorder. If this should prove insufficient for some special purpose, a second control cabinet may be connected in multiple with the first cabinet, making provision for four more motors.

Various desirable features, such as ability to slate independently or operate from a central source, and the assurance that slating will not have left motors off the line, are provided for by the use of relays for controlling motor circuits. Thus for each motor there is an a-c disconnect relay, an a-c "synch" light relay, and an a-c slow-start relay; for d-c operation, a d-c disconnect relay and a d-c



FIG. 5. Switching and junction box.

slow-start relay, thus providing a total of five relays per motor. Since approximately one-half of these relays are idle on any given mode of operation, the complication involved is more apparent than real. From a maintenance standpoint, relays of the type used are to be preferred to switches since they lend themselves to ready inspection and are purposely mounted with the contacts immediately accessible for any necessary cleaning operation. Any burning or blackening of the contacts can be observed and corrected, whereas with switches such a burning would only make itself known by switch failure.

Independent "Slating" for Cameras.—A small switching and junction box is provided for each camera motor (Fig. 5). This is attached to the camera and provides a termination for the two cables from the central control box. It is so arranged that the cameraman may run the camera independently of the rest of the system by simply throwing a switch. This is of particular value for "slating" and "wild shots." As noted below, a pilot-light indicates to the recording operator when the camera is being run, allowing him to check, and, if necessary, correct the speed at that time.

Automatic Slow-Speed Start.—Since the motors are designed to supply sufficient power for the heaviest loads, it was found desirable to incorporate a starting control so that light loads would not be started too abruptly. This was done by including in both a-c and d-c supply-circuits adjustable resistances which are shorted by relays whose coils are excited from the armature circuit. In this way the individual circuits may be adjusted so that all motors come up to speed without jerking and in approximately the same time.

A-c-D-c Running Pilot-Lights.—A pilot-light is provided for each motor circuit to indicate when the motor is running. When running on d-c, this permits the operator to adjust the motor speed without running the motor especially for this purpose. It is useful in a-c operation to show which motor is running but not synchronized.

Synchronizing Pilot-Light.—A red "synch" light is used for a-c operation and acts as a pilot-light to indicate whether the three-phase supply is connected to the control cabinet. The circuit is arranged so that this light goes out when the last machine is synchronized with the line. This also serves to indicate if a motor drops out of synchronism for any reason such as poor contacts in motor cables. On d-c operation the ballast resistors in the interlock circuits serve a similar purpose. These flash for "out-of-synch" conditions, but are dark when the motors are properly interlocked. These indications of synchronism are useful to the operator in order that he may make the synchronizing mark or "bloop" with a little delay as possible and yet be sure that all motors are actually in synchronism when the mark is applied.

Synchronizing or "Bloop" Marks.—The synchronizing circuit is manually operated by the operator from the central control cabinet. The "bloop" switch is a momentary contact, push-button type, and marks the picture film by applying an alternating voltage to an argon lamp in the camera which is in series with a buzzer at each camera. This operation also marks the sound-track by applying the same signal to the light-valve. A pilot-light in the cabinet is in series with the buzzer at each camera and the marking light inside the camera. Thus the pilot-light glows dimly when the circuit is normal, does not light at all when the circuit is open and glows brilliantly if the light in the camera is shorted. The buzzer at the camera furnishes a signal to the set that the motor has reached normal speed and is synchronized. This permits the action to start more quickly than when it is necessary to signal back and forth between stage and recorder position. This circuit has also the advantage that it is a completely separate circuit and is less likely to interfere with other circuits or to be interfered with than where it is "phantomed" on circuits designed for some other purpose.

Speed Indication and Adjustment.—Since the d-c system is usually used without a master speed-control in order to obtain maximum portability, it is necessary to have an accurate speed indicator to show when the proper speed is reached. This is provided by means of a dual-range tachometer with one scale covering the range between 82 and 93 feet per minute. It is also desirable to be able to operate the system at less than normal speed for special effects. The lower speed range is obtained with the d-c system by tapping the supply-battery down to one-half normal voltage in 12-volt steps. This provides stability at lower speeds comparable to that obtained at normal speed. The speed in this range is read in frames per second on a second scale of the tachometer. A voltmeter is also provided for

reading battery voltage as supplied through the tap switch and therefore reduces the likelihood of the tap being left on a subnormal position.

Film-Buckle Release.—The film-buckle release switch at each camera carries only relay-coil current and thus is protected against excessive burning and arcing common to most other systems. This switch may be used as a disconnect switch by cameramen without the previous penalty of high maintenance.

Other Control Cabinets.—While it was originally intended that the a-c-d-c cabinet would serve for either stage or location duty, it has become apparent that some studios have such a high percentage of stage operation that the d-c equipment in most a-c-d-c boxes would have very little use. To meet this condition a cabinet has been designed for non-portable stage use only, which contains only those elements necessary to a-c operation. While a box for use only on d-c has been schematically designed, it has been generally contended that for portable use the a-c-d-c box is desirable because of the fact that many locations would permit operation on a-c even though they may be many miles from home. A control-box has been designed to operate any type of standard synchronous motor which might be used on a recorder in conjunction with the new system. This unit contains the necessary units to start and "bloop" the whole system when it is desired that the recorder man assume this function and will operate either in conjunction with the a-c only or the a-c-d-c box.

Background Projection.—For background projection a cabinet is provided which will work in conjunction with either the a-c-d-c cabinet or the a-c only unit on either a-c or d-c supply. The auxiliary cables from each motor go first to this background projection cabinet and then to the main control cabinet *via* short jumpers. A contact at each motor which is mechanically coupled to the shutter effectively indicates to the central circuit when the shutters of each machine are open. The control circuit then compares the shutter position of each camera with that of the projector and automatically adjusts the shutter positions so that all are open at the same time by momentarily disconnecting any whose position is not correct and dropping it back until such time as the shutter does align. A visual indication of the phase relations of the shutters is provided in this cabinet so that the operator may observe the actual functioning of the automatic circuit and, if necessary, phase in the various units manually by operating the associated disconnect switches. This is intended to provide against possible failure at an inopportune time of the automatic facilities and it also provides a means which is not available in any present system of determining that the shutters are in proper alignment throughout the take. This method of shutter phasing has the further advantage that it will work equally well on either a-c or d-c and consumes practically no additional power. It seems possible that due to the reduction in power consumption and its associated reduction in weight and bulk, this feature may make feasible background projection on distant locations which have not been considered practicable before.

It has been the aim throughout the development of this system to include only features that a majority of the studios were agreed upon as desirable, but at the same time provision has been made in many cases to provide facilities that can be added to meet special needs. For instance, automatic speed control does not seem to be justified for location work and the multiduty system obtains speed control from the supply-line for stage use, but if sufficient demand for this feature arises,

it can be added without altering existing equipment. The motor speeds have been based on the prevalence of a 60-cycle supply frequency but the motors can readily be wound to operate on 48 cycles where a 1440-rpm speed is essential for direct shutter-shaft drive. Possibly some of the many facilities and indicators that have been included will prove non-essential in the field and it is possible that some essential items have been omitted. However, this is the first time that a motor-system has been made available in which the auxiliary features necessary to smooth, efficient action on the set have been incorporated as an inherent part of the system. Considerable direct saving in both time and wasted film should result from the use of these facilities and a further indirect saving should be realized from the fact that a wide range of operating conditions can be met without a material change of either equipment or operating technic.

It is desired to thank those in the industry who have helped define these requirements, and particularly Paramount for the field tests and the suggestions contributed by the sound department staff.

DISCUSSION

MR. READ: You stated in the paper that the stiffness of coupling or deflection angle for a given load was half for the motor with a d-c field over that with the induced field, or variable-reluctance motor. With the motor with the d-c field you would expect to reach maximum torque at 90 electrical degrees deflection. With the other type of motor, you would have to obtain maximum torque at a smaller value than that, because at 90 degrees it would have passed the point of stability and be slipping a pole.

MR. KEITH: I believe the first part of your question referred to the difference in the coupling between the d-c and the a-c motors.

MR. READ: I referred to your using both motors as a-c motors—in one case using the conventional squirrel-cage motor, which has part of the rotor cut away, to make it pull into synchronism; and in the other case a motor with a d-c field. I understood that the one with the d-c field had twice the stiffness of coupling.

MR. KEITH: The one with the additional self-excited d-c field has greater coupling than the one with a simple synchronous motor.

MR. READ: Assuming that each type of motor is designed for the same maximum pull-out torque, I would appreciate an explanation of why the self-excited d-c field has greater stiffness than the simple synchronous type.

MR. KEITH: I believe the difference is the distribution of flux about the poles rather than in the difference in form of operation.

MR. HOLCOMB:* Mr. Keith is correct in that the sharper coupling is due to a difference in flux pattern. In practice the variable-reluctance synchronous camera motor operates in synchronism essentially as if the rotor were a bar of iron which follows the rotating flux of the stator and seeks to occupy the position of greatest flux density at all times. The angle of lag introduced by any given load on the rotor will depend on the shape and coverage of the rotor poles. Thus one such rotor might have the area between poles relieved so that the air-gap increased

* Communicated.

uniformly from the center of the poles; another rotor might be slotted abruptly and deeply between poles. Both rotors might have the same maximum torque or pull-out, but a very different response in angular position to changing loads at less than pull-out torques. The power of any type of synchronous motor that must start under full-load conditions is determined by the load which it can pull into synchronism, and this value is usually much less than the motor will maintain when once in step. This fact, added to the requirement that camera motors operate with a considerable margin of safety, with respect to power, means that the average motor works at less than 20 degrees displacement, and thus never approaches the theoretical 90 degrees mentioned. The "pull-in" and mechanical considerations dictate to a large extent the slotting of most variable-reluctance synchronous motors rather than sharpness of coupling, and while this type of motor could be designed for a coupling characteristic equal to that of the multiduty type it probably would require a larger and heavier frame. The d-c excitation on the fields of the multiduty motors increases the flux density without materially increasing the leakage, and thus improves the definition of the flux pattern.

MR. KELLOGG: The point was made several times in the paper that the efficiency is very high. Are there any particular design features that would make it any more efficient, for example, than a d-c motor of about the same size?

MR. KEITH: I do not believe it was meant that the motors, as constructed, are more efficient than a simple d-c motor without interlocking windings, but more efficient than other systems of d-c interlocked motors.

MR. KELLOGG: According to the diagram, there was no extra winding. I have been under the impression that some motors now in use had a low-voltage d-c winding supplemented by a high-voltage a-c winding, making the machine like an a-c—d-c dynamotor rather than a rotary converter.

MR. KEITH: True; some systems have been used where the a-c interlock was obtained by a separate high-voltage winding—where the a-c interlock circuit is separate from the d-c circuit. In these motors that is not done; the interlock circuit is taken directly from the commutator.

MR. HOLCOMB:* The motor system to which Mr. Kellogg refers is the 12-volt d-c interlock system introduced by ERPI some years ago, which has a 12-volt d-c motor winding and separate 220-volt 3-phase interlock winding. In the multiduty motors the same rotor winding serves three purposes: (1) as a d-c motor winding, (2) as an interlock winding; (3) as a delta-connected 3-phase motor winding. Since there is no "dead" copper in any mode of operation, the space-factor in the rotor is optimum. The stator, however, presents a difficult design problem due to the fact that both the d-c field winding and the short-circuited squirrel-cage winding must occupy essentially the same space or push the size of the motor beyond desirable limits.

MR. KELLOGG: You refer to bars in the pole-pieces, so that you can start the machine as an induction motor?

MR. KEITH: Yes.

MR. READ: How does this machine differ in design from any standard 3-phase rotary converter? Are there any features that would make it more efficient? What is the size of the motor?

MR. KEITH: I do not know the figures of the relative efficiency, compared with standard converter, but I see no reason why it would be any more efficient in any one feature. I think it is simply that they are more efficient than previously used motors, because of refinements in design and the number of small details. The camera motor is roughly 5 inches in diameter and 6 inches long, exclusive of the shaft extension.

MR. KELLOGG: And that is good for 200 watts?

MR. KEITH: 300 watts on d-c.

MR. HOLCOMB:* The efficiency of the multiduty motors as stated by Mr. Keith is relative to existing systems intended for the same duty. The design problem is twofold: to produce a unit which delivers a high ratio of output to input, particularly for d-c operation work, where the size and weight of the power source must be kept to a minimum; at the same time the size and weight of the camera motors must be held low. This is accomplished by careful design consideration of all losses, and a handmade type of construction which, while expensive, utilizes all the available space in the motor to the best advantage. For operation on the stage as synchronous motors the efficiency is high because the power-factor is good, due to self-excitation, and the resultant low-current demand materially reduces the I^2R losses.

MR. KELLOGG: What is the a-c voltage at which they operate?

MR. KEITH: The supply is 65 volts a-c.

CURRENT LITERATURE OF INTEREST TO THE MOTION PICTURE ENGINEER

The editors present for convenient reference a list of articles dealing with subjects cognate to motion picture engineering published in a number of selected journals. Photostatic copies may be obtained from the Library of Congress, Washington, D. C., or from the New York Public Library, New York, N. Y. Micro copies of articles in magazines that are available may be obtained from the Bibliofilm Service, Department of Agriculture, Washington, D. C.

Acoustical Society of America, Journal

11 (October, 1939), No. 2

Normal Modes of Vibration in Room Acoustics:

Experimental Investigations in Nonrectangular Enclosures (pp. 184-197)

R. H. BOLT

A Sound Source for Investigating Microphone Distortion (pp. 219-221)

W. D. PHELPS

Microphone Efficiency: A Discussion and Proposed Definition (pp. 222-224)

F. MASSA

The Degenerative Sound Analyzer (pp. 225-232)

H. H. SCOTT

American Cinematographer

20 (November, 1939), No. 11

Fine-Grain Films Make Strong Advance (pp. 486-488)

G. BLAISDELL

Sound Quality Improvements Obtained with Fine Grain Films (pp. 489-490)

C. R. DAILY

Making Modern Matte-Shots (pp. 493-495, 526), Pt. I

B. HASKIN

Pacific Laboratories Announce Complete 16-mm. Service (pp. 497, 517)

Studying Photoelectric Exposure Metering (pp. 499-500, 524), Pt. I

D. NORWOOD

Eastman Issuing Two Classy Camera Models (p. 506)

Here Are Tips on Editing and Splicing (pp. 508-509)

J. A. SHERLOCK

Educating 300,000 with 16-Mm. Movies (pp. 510, 519)

A. J. PATEL

Densitometry and Its Application to Motion Picture Laboratory Practice (pp. 512, 513, 520), Pt. III

E. HUSE AND

G. CHAMBERS

British Journal of Photography

86 (September 22, 1939), No. 4142

Progress in Color (p. 587)

86 (September 29, 1939), No. 4143

Progress in Color (pp. 603-604)

86 (October 6, 1939), No. 4144

Progress in Color (pp. 611-612)

86 (October 20, 1939), No. 4146

Progress in Color (pp. 638-639)

86 (October 27, 1939), No. 4147

Progress in Color (pp. 647-648)

British Kinematograph Society, Journal

2 (October, 1939), No. 4

Photographic Light Filters (pp. 215-222)

G. J. CRAIG

The Appraisal of Carbons for the Illumination of
Kinema Screens (pp. 226-234)

F. S. HAWKINS

Educational Screen

18 (October, 1939), No. 8

Motion Pictures—Not for Theaters (pp. 284-288)

A. E. KROWS

International Photographer

11 (October, 1939), No. 9

Fine-Grain Release Prints (pp. 5-8)

Mixing Weights and Measures (p. 10), Pt. 2

DON HOOPER

International Projectionist

14 (September, 1939), No. 8

Ashcraft "Cyclex" Projection System (pp. 7-8, 10)

J. J. FINN

Flicker in Motion Pictures (pp. 18-20, 24-26)

L. D. GRIGNON

14 (October, 1939), No. 9

Design and Operating Data on the "Cyclex" Projection
system (pp. 7-14)

D. S. ASHCRAFT

Color Film Screen Values (pp. 16, 25-27)

W. C. HARCUS

Technicolor Adventures in Cinemaland (pp. 21-24)

H. T. KALMUS

Kinotechnik

21 (September, 1939), No. 9

Beziehungen Zwischen Bild- und Tonsensitometrie (Relation
between Image and Sound Sensitometry) (pp. 223-
227)

A. NARATH

Die Entwicklung der deutschen Kinoprojektoren (The
Development of German Motion Picture Projectors)
(pp. 228-231)

H. FICHTNER

Die Kinotechnik in der Patentstatistik, 1938 (Motion
Pictures in Patent Statistics for 1938) (pp. 231-232)

F. BARTH

Photographische Industrie

37 (September 20, 1939), No. 38

Optische Kontrolle der Tonkopie (Optical of Sound
Prints) (pp. 1039-1040)

37 (September 27, 1939), No. 39

Ein Vorschlag zum photographischen Aufzeichnen von
Tönen aus dem Jahre 1880 (A Proposal for Photographic
Sound Recording in the Year 1880) (p. 1055)

BOOK REVIEW

Applied Acoustics; Harry F. Olson and Frank Massa; *P. Blankiston's Son & Co. Inc.*, Philadelphia, Pa. (March, 1939).

Although the subject of acoustics is very old, the early publications are devoted principally to scientific explanation of the phenomena observed. Early work on apparatus for production of sounds was limited almost entirely to the field of musical instruments. The invention of the telephone and later the vacuum-tube amplifier opened the field of modern acoustics. Means for recording, transmitting, and reproducing sound shifted the emphasis on acoustics from its academic to its economic aspects. There followed a period of rapid development from which emerged industries of the first magnitude having their origin in applied acoustics.

This application of the science of acoustics is well treated in the book under review. The authors have had intimate contact with all the modern developments and have made many original contributions thereto. The early chapters give sufficient discussion of fundamentals to serve as a guide to experimental work and a check on results. The greater portion of the book, however, is devoted to a description of apparatus and technic which have been developed during the past two decades for use in the fields of radio broadcasting and sound pictures. The descriptive matter is written so as to be understandable without thorough mastery of the theoretical work. The apparatus is discussed both from the standpoint of the designer and the user.

The second edition is justified in view of the rapid strides which have been made recently in the development of microphones and loud speakers. While the principal changes from the earlier edition are in the discussions of these elements, changes in matter and presentation are made throughout the book where necessary to bring it up to date. It should be helpful to anyone desiring to become familiar with the latest developments in the field of applied acoustics.

C. A. LOVELL

1940 SPRING CONVENTION

SOCIETY OF MOTION PICTURE ENGINEERS

CHALFONTE-HADDON HALL, ATLANTIC CITY, NEW JERSEY
APRIL 22-25, INCLUSIVE

Officers and Committees in Charge

E. A. WILLIFORD, *President*
S. K. WOLF, *Past-President*
W. C. KUNZMANN, *Convention Vice-President*
J. I. CRABTREE, *Editorial Vice-President*
S. HARRIS, *Chairman, Papers Committee*
J. HABER, *Chairman, Publicity Committee*
H. GRIFFIN, *Chairman, Convention Projection*
E. R. GEIB, *Chairman, Membership Committee*
H. BLUMBERG, *Chairman, Local Arrangements*

Reception and Local Arrangements

HARRY BLUMBERG, *Chairman*

M. C. BATSEL	E. O. WILSCHKE	E. W. KELLOGG
A. B. FREEMAN	W. J. CHARLES	H. WALTERS
C. A. SEUBERT	M. LEWIS	F. B. EVANS
C. W. TREEN	W. CONNER	L. RATENER

Registration and Information

W. C. KUNZMANN, *Chairman*

E. R. GEIB	J. FRANK, JR.	F. HOHMEISTER
------------	---------------	---------------

Hotel and Transportation

E. O. WILSCHKE, *Chairman*

S. ABRAMS	C. A. SEUBERT	J. DEFRENES
C. COHEN	B. BLUMBERG	H. J. MAIRE
F. J. BETTELLI	C. PRESGRAVE	G. L. DIMMICK

Publicity

J. HABER, *Chairman*

S. HARRIS	P. A. MCGUIRE
J. J. FINN	F. H. RICHARDSON

Convention Projection

H. GRIFFIN, *Chairman*

M. C. BATSEL	H. BLUMBERG	E. O. WILSCHKE
M. LEWIS	H. WALTERS	W. J. CHARLES
C. W. TREEN	F. HOHMEISTER	A. B. FREEMAN

Officers and Members Projectionists Local 310, IATSE

Banquet and Dance

H. BLUMBERG	M. C. BATSEL, <i>Chairman</i>	B. BLUMBERG
W. J. CHARLES	E. W. KELLOGG	A. B. FREEMAN
E. O. WILSCHKE	H. WALTERS	C. W. TREEN
	O. F. NEU	

Ladies Reception CommitteeMRS. O. F. NEU, *Hostess**assisted by*

MRS. M. C. BATSEL	MRS. E. O. WILSCHKE
MRS. H. BLUMBERG	MRS. C. W. TREEN
MRS. A. B. FREEMAN	MRS. B. BLUMBERG
MISS L. A. MOYER, <i>Hostess</i> , Chalfonte-Haddon Hall	

Headquarters

Headquarters.—The headquarters of the Convention will be the Chalfonte-Haddon Hall, where excellent accommodations have been assured, and a reception suite will be provided for the Ladies' Committee.

Reservations.—Early in March room reservation cards will be mailed to members of the Society. These cards should be returned as promptly as possible in order to be assured of satisfactory accommodations.

Hotel rates.—Special rates have been guaranteed by the Chalfonte-Haddon Hall to SMPE delegates and their guests. These rates, European plan, will be as follows:

	<i>Four Lower Floors</i>	<i>Ocean View</i>	<i>Ocean Front</i>
Room for one person	\$ 3.50	\$ 4.00	\$ 5.00
Room for two persons	6.00	7.00	8.00
Parlor Suite, for one	10.00	12.00	14.00
Parlor Suite, for two	14.00	16.00	18.00

(All bathrooms at Haddon Hall have hot and cold running fresh and salt water)

If American plan rates are desired the hotel room clerk should be advised accordingly when registering. An additional charge of \$3 per day per person will be added to the above-listed European rates for three daily meals, American plan. Members and guests registering at the hotel on the American plan will pay only \$3 for the SMPE banquet scheduled at Haddon Hall on Wednesday evening, April 24th. If registered on the American plan, the clerk at registration headquarters should be advised accordingly when procuring your banquet tickets.

Parking.—Parking accommodations will be available to those who motor to the Convention at the Chalfonte-Haddon Hall garage, at the rate of 50¢ for day parking or \$1.25 for twenty-four hours. These rates include pick-up and delivery of car.

Registration.—The registration and information headquarters will be located at the entrance of the *Viking Room* on the ballroom floor where the technical and business sessions will be held. All members and guests attending the Convention

are expected to register and receive their badges and identification cards required for admission to all the sessions of the Convention, as well as to several motion picture theaters in the vicinity of the Hotel.

Technical Sessions

The technical sessions of the Convention will be held in the *Viking Room* of the Hotel. The Papers Committee plans to have a very attractive program on papers and presentations, the details of which will be published in a later issue of the JOURNAL.

Luncheon and Banquet

The usual informal get-together luncheon will be held in the *Benjamin West Room* of Haddon Hall on Monday, April 22nd, at 12:30 p.m. The forty-sixth Semi-Annual Banquet and Dance of the Society will occur on the evening of Wednesday, April 24th, in the *Rulland Room* of Haddon Hall—an evening of dancing and entertainment for members and guests.

Ladies' Program

A specially attractive program for the ladies attending the Convention is being arranged by Mrs. O. F. Neu, *Hostess*, and the Ladies' Committee. A suite will be provided in the Hotel where the ladies will register and meet for the various events upon their program. Further details will be published in a succeeding issue of the JOURNAL.

Entertainment

At the time of registering, passes will be issued to the delegates of the Convention admitting them to several motion picture theaters in the vicinity of the Hotel. The names of the theaters will be announced later.

Atlantic City's boardwalk along the beach offers a great variety of interests, including many attractive shops and places of entertainment.

W. C. KUNZMANN,
Convention Vice-President

SOCIETY ANNOUNCEMENTS

ATLANTIC COAST SECTION

As the result of the recent balloting for officers and managers of the Atlantic Coast Section, the successful candidates for 1940 are as follows:

P. J. LARSEN, *Chairman*
J. A. MAURER, *Sec.-Treas.*
R. O. STROCK, *Manager*

D. E. Hyndman continues on the Board of Managers as Past-Chairman, and the term of H. Griffin, Manager, has another year to run.

Tentative arrangements for the next four meetings of the Section have been made as follows:

January 10, 1940.—Further discussion of high-quality 16-mm recording, and 16-mm negative-positive and duplicate negative technic, by J. A. Maurer, of the Berndt-Maurer Corp., New York, N. Y. There is also the possibility of a paper by a representative of Electrical Research Products, Inc.

February 14, 1940.—The CBS Broadcasting System Television Station, by P. C. Goldmark and John Dyer (at the CBS Studios in the Grand Central Station Building, New York, N. Y.).

March 13, 1940.—Motion Picture Film as Related to Television, by representatives of the Eastman Kodak Co., Columbia Broadcasting System, National Broadcasting System, and Baird Television Corp.

April 10, 1940.—A demonstration and description of the large-size Baird theater television screen, by Edward Truefitt, of the Baird Television Corp.

This list is fairly certain, although it is subject to change in the event of unforeseen circumstances.

On December 13th, a meeting of the Section was held at the Hotel Pennsylvania, New York, at which time Mr. F. E. Carlson of the Lamp Department of the General Electric Company presented a paper on "The Characteristics of Vapor Light-Sources." The paper was of a tutorial nature, discussing the characteristics of vapor sources operating under the combination of variables of pressure and of current density. Transmission characteristics of the envelope and other pertinent characteristics were included. The practical adaptation of light-sources having these characteristics were enumerated as applying particularly to projection and printing light sources.

MID-WEST SECTION

Results of the election of officers and managers of the Mid-West Section for 1940 were as follows:

J. A. DUBRAY, *Chairman*
I. JACOBSEN, *Sec.-Treas.*
C. H. STONE, *Manager*

S. A. Lukes continues on the Board of Managers as Past-Chairman, and also O. B. Depue, as Manager, whose term has one more year to run.

At the November 20th meeting, held in the meeting rooms of The Western Society of Engineers, Chicago, the following two papers, originally presented at the October convention of the Society at New York, were re-presented for the benefit of the mid-western members:

"Lenses for Amateur Motion Picture Equipment (16-Mm and 8-Mm)," by R. Kingslake of the Eastman Kodak Company, Rochester, N. Y.

"Some Industrial Applications of Current 16-Mm Sound Motion Picture Equipment," by W. H. Offenhauser and F. H. Hargrove, of The Berndt-Maurer Corporation, New York, N. Y.

On December 19th, an additional meeting was held, at which time Mr. M. Wenzel of the Wenzel Company, Chicago, presented a paper on "New Developments in Theater Motion Picture and Sound Projectors."

Both meetings were well attended and considerable discussion followed the presentations.

PACIFIC COAST SECTION

Elections of officers and managers of the Pacific Coast Section are now in progress, and the results will be announced in the next issue of the JOURNAL.

At a meeting held in the RCA Building, Hollywood, on November 20th, two papers dealing with television were presented as follows:

"Discussion of RCA Television Demonstration Unit," by W. C. Turner.

"Discussion of Television Receiver Installation Problems," by I. Steinberger.

Following the discussions, an opportunity was presented to inspect the television transmitter-receiver demonstration unit. This is the unit that was displayed at the San Francisco Fair by RCA.

ADMISSIONS COMMITTEE

At a recent meeting of the Admissions Committee at the General Office of the Society, the following applicants for membership were admitted to the Associate grade:

BACK, F. G.

309 E. 23rd St.,
New York, N. Y.

BROWN, E. T.

Southern Amusement Co.,
Lake Charles, La.

BROWNE, E. A.

44 Clement Ave.,
West Roxbury, Mass.

BURGER, M. J.

121-18 109th Ave.,
So. Ozone Park, N. Y.

BURNS, S. F.

Piedmont Hotel,
Seattle, Wash.

EDWARDS, L. M.

1905 Nottingham Way,
Trenton, N. J.

FURST, U. R.

81 Green St.,
Brookline, Mass.

HUMBY, W. W.

30 Visaat St.,
Saint John No. 8,
Canada.

McCLELLAN, E. W., JR.

195 Broadway,
New York, N. Y.

MACBETH, N.

227 W. 17th St.,
New York, N. Y.

MARTIN, K. H.

Midland Television, Inc.,
Kansas City, Mo.

MISTRY, H.

24 Nepean Rd.,
Malabar Hill,
Bombay, India.

MUNSON, A. L.

4246 Deyo Ave.,
Congress Park, Ill.

PLANT, F. W.

15 Derby St.,
Sydney, Australia.

RALPH, C. M.

General Service Studios, Inc.,
6625 Romaine St.,
Hollywood, Calif.

RYAN, L. F.

4600 N. Winchester Ave.,
Chicago, Ill.

STATLER, M. T.

Columbia Broadcasting System,
15 Vanderbilt Ave.,
New York, N. Y.

TABERNERO, P.

Vidal 1670,
Buenos Aires, Argentina.

VAN DER SCHALIE, H.

52 Vanderbilt Ave.,
New York, N. Y.

In addition, the following applicants have been admitted by vote of the Board of Governors to the Active grade:

BOECKING, E.

173 Hillcrest St.,
Great Kills, S. I., N. Y.

BOWDITCH, F. T.

National Carbon Co.,
Box 6087,
Cleveland, Ohio

COLBURN, G. W.

1197 Merchandise Mart,
Chicago, Ill.

FALGE, F. M.

General Electric Co.,
601 West 5th St.,
Los Angeles, Calif.

ISAAC, L. B.

Loew's, Inc.,
1540 Broadway,
New York, N. Y.

TESCH, W. L.

22 Stokes Terrace,
Moorestown, N. J.

SHULTZ, C. E.

39 Orange Rd.,
Montclair, N. J.

YORKE, E. E.

245 W. 55th St.,
New York, N. Y.

JOURNAL

OF THE SOCIETY OF

MOTION PICTURE ENGINEERS

Volume XXXIV

February, 1940

CONTENTS

	<i>Page</i>
Report of the Projection Practice Committee.....	125
Future Development in the Field of the Projectionist.....	131
A. N. GOLDSMITH	
Projection Room Planning for Safety.....	134
E. R. MORIN	
The Projectionist's Part in Maintenance and Servicing.....	143
J. R. PRATER	
Possible Methods for Encouraging Study by Projectionists....	154
F. H. RICHARDSON	
Some Industrial Applications of Current 16-Mm Sound Motion Picture Equipment.....	156
W. H. OFFENHAUSER, JR., AND F. H. HARGROVE	
A Reel and Tray Developing Machine.....	168
R. S. LEONARD	
Considerations Relating to Warbled Frequency Films.....	177
E. S. SEELEY	
Science and the Motion Picture.....	193
H. ROGER	
The Preservation of History in the Crypt of Civilization.....	206
T. K. PETERS	
New Motion Picture Apparatus	
A New High-Quality Sound System.....	212
G. FRIEDL, JR., H. BARNETT, AND E. J. SHORTT	
Simplex Double-Film Attachment.....	219
W. BORBERG AND E. PIRNER	
A Non-Intermittent Motion Picture Projector.....	223
F. EHRENFHART AND F. G. BACK	
Current Literature.....	232
Book Review.....	234
1940 Spring Convention at Atlantic City, N. J., April 22nd-25th	235
Society Announcements.....	238

JOURNAL OF THE SOCIETY OF MOTION PICTURE ENGINEERS

SYLVAN HARRIS, EDITOR

Board of Editors

J. I. CRABTREE, *Chairman*

A. N. GOLDSMITH

A. C. HARDY

T. E. SHEA

J. G. FRAYNE

L. A. JONES

G. E. MATTHEWS

E. W. KELLOGG

Subscription to non-members, \$8.00 per annum; to members, \$5.00 per annum, included in their annual membership dues; single copies, \$1.00. A discount on subscription or single copies of 15 per cent is allowed to accredited agencies. Order from the Society of Motion Picture Engineers, Inc., 20th and Northampton Sts., Easton, Pa., or Hotel Pennsylvania, New York, N. Y.

Published monthly at Easton, Pa., by the Society of Motion Picture Engineers.

Publication Office, 20th & Northampton Sts., Easton, Pa.

General and Editorial Office, Hotel Pennsylvania, New York, N. Y.

West Coast Office, Suite 226, Equitable Bldg., Hollywood, Calif.

Entered as second class matter January 15, 1930, at the Post Office at Easton, Pa., under the Act of March 3, 1879. Copyrighted, 1940, by the Society of Motion Picture Engineers, Inc.

Papers appearing in this Journal may be reprinted, abstracted, or abridged provided credit is given to the Journal of the Society of Motion Picture Engineers and to the author, or authors, of the papers in question. Exact reference as to the volume, number, and page of the Journal must be given. The Society is not responsible for statements made by authors.

OFFICERS OF THE SOCIETY

* *President:* E. A. WILLIFORD, 30 East 42nd St., New York, N. Y.

* *Past-President:* S. K. WOLF, RKO Building, New York, N. Y.

* *Executive Vice-President:* N. LEVINSON, Burbank, Calif.

** *Engineering Vice-President:* D. E. HYNDMAN, 350 Madison Ave., New York, N. Y.

* *Editorial Vice-President:* J. I. CRABTREE, Kodak Park, Rochester, N. Y.

** *Financial Vice-President:* A. S. DICKINSON, 28 W. 44th St., New York, N. Y.

* *Convention Vice-President:* W. C. KUNZMANN, Box 6087, Cleveland, Ohio.

* *Secretary:* J. FRANK, JR., 356 W. 44th St., New York, N. Y.

* *Treasurer:* R. O. STROCK, 35-11 35th St., Astoria, Long Island, N. Y.

GOVERNORS

* M. C. BATSEL, Front and Market Sts., Camden, N. J.

* J. A. DUBRAY, 1801 Larchmont Ave., Chicago, Ill.

** A. N. GOLDSMITH, 444 Madison Ave., New York, N. Y.

** H. GRIFFIN, 90 Gold St., New York, N. Y.

* P. J. LARSEN, 29 S. Munn Ave., East Orange, N. J.

* L. L. RYDER, 5451 Marathon St., Hollywood, Calif.

** A. C. HARDY, Massachusetts Institute of Technology, Cambridge, Mass.

* H. G. TASKER, 14065 Valley Vista Blvd., Van Nuys, Calif.

* Term expires December 31, 1940.

** Term expires December 31, 1941.

REPORT OF THE PROJECTION PRACTICE COMMITTEE*

Summary.—A brief account of the work of the Committee during the past year, in which is traced the evolution of the SMPE Projection Room plans and their general adoption by the industry. Work is being initiated by the Sub-Committee on Theater Structures in a study of the disparity that exists among various state and municipal motion picture regulations. The subject of heating projection rooms is also reported upon by the Sub-Committee on Fire Hazards. Work has been begun by the Sub-Committee on the Power Survey in determining the average or representative operating conditions, with particular respect to the power consumed, in theaters of various seating capacities and equipped with various types of projection apparatus.

During the past year, the Committee has undertaken and successfully brought to fruition several major projects of outstanding importance to the technologic groups of the motion picture industry. Moreover, the Committee is gratified to note that its recommendations to the industry have been widely accepted and put into general practice. Indeed the principal purpose of the Committee is to investigate any problem of projection that may be facing the industry, to determine the existing circumstances, and to recommend any alterations in these circumstances that may be dictated by the needs of good projection.

Perhaps one of the most important of the projects that has been undertaken by the Committee is the revision of the earlier projection room plans. The first set of projection room plans was drawn up by the Committee in 1930, and since that time the many advances in the art of projection and in the projection equipment have made it necessary to revise the plans, the latest edition being that published in the November, 1938, issue of the JOURNAL. Naturally, the establishment of a set of plans aiming toward a high level of projection, operation, maintenance, and safety would lead toward a thorough investigation of projection room design from the point of view of fire prevention and control. These plans and survey have been published in *The Architecture Record*, thus bringing them to the attention of architects of the country and so contributing toward improvement in theater design. In the same issue of the JOURNAL was published a

* Presented at the 1939 Fall Meeting at New York, N. Y.; received October 15, 1939.

comprehensive revision of the "Regulations for Handling Nitro-cellulose Motion Picture Film" of the National Fire Protection Association, the original edition of which was brought out in 1931. Obviously, in view of the marked advances in the art since 1931 these regulations required thorough revision.

After study of the proposed revision, by the Committee on Hazardous Chemicals and Explosives of the NFPA, the revision was voted upon at the May, 1939, meeting of the NFPA at Chicago and was adopted practically without change. A few additional points not covered in the present revision still remain, but these features will be taken under advisement by the Projection Practice Committee during the coming season. The NFPA has recently issued a revised booklet of regulations, which may be obtained upon request to them.

The revision of the regulations was based in large part upon the great improvement that has occurred during recent years in the construction of motion picture projection rooms—and this improvement, the Committee feels, is largely due to the Projection Room Plans originally issued in 1930 and periodically brought up to date. One of the most interesting results of this work was a recent ruling in the State of Connecticut with regard to the use of sprinklers in motion picture projection rooms. The SMPE projection room plans form the basis of the Connecticut State Regulations and, in turn, the New England Fire Insurance Rating Association has ruled that in motion picture projection rooms, constructed and protected in accordance with the requirements of the State of Connecticut, automatic sprinkler protection may be omitted from the projection room. It is further recommended by the New England Fire Insurance Rating Association that the soda-and-acid chemical extinguishers be placed immediately outside the projection room rather than inside.

It has long been the opinion of the Projection Practice Committee and the Sub-Committee on Fire Hazards that automatic sprinklers might well be omitted from projection rooms in view of the high speed with which film burns and the great damage done to the sound and projection equipment when the automatic sprinkler valves are released. A reel of film set on fire will often burn itself out before the sprinklers have had a chance to operate; then afterward the heat of the room may release the sprinklers. In projection rooms designed in accordance with the SMPE Projection Room Plans and the requirements of the State of Connecticut, the chances of fire in such projection rooms are very much lessened and, in addition, the transmission

of the fire beyond the confines of the projection room so constructed is practically negligible. It is on these bases that the State of Connecticut and the Committee recommend that sprinklers be omitted, and it is a source of satisfaction to the Committee to be able to trace this evolution of practice back to its original SMPE Projection Room Plans.

MOTION PICTURE CODES

One of the most troublesome features of projection room design, construction, and installation of equipment is the great disparity that exists among various state and municipal motion picture regulations. The extent to which these various codes differ and conflict has been very forcibly shown by the Board of Labor statistics of the United States Department of Labor in a publication in the *Monthly Labor Review* of January, 1938, which dealt specifically with "Safety Standards for Motion Picture Machine Operators." It is not necessary at this point to go into these differences, as the original publication in the *Monthly Labor Review* may easily be consulted. However, it is well known that such disagreement and conflict among the codes of the states and municipalities exist not only with respect to projection rooms but also in relation to theater structure and auditorium conditions. The Sub-Committee on Theater Structures has been engaged in studying these problems, the latter subject, namely, auditorium conditions, including both lighting and acoustic treatments, as well as other factors related to the viewing and hearing of motion picture productions.

The first step in the work is to obtain copies of the codes of all the states and important municipalities. When these codes have been received they will be compared and analyzed in the hope that ultimately a representative code might be drawn up for submission to the various states and municipalities, with the view of fostering uniformity in their regulations. This is admittedly an ambitious program. However, at least one state, namely, Connecticut, is already working very closely with the Committee, and the influence of the Committee's work is being felt throughout the country by virtue of its recent recommendations toward revision of the NFPA regulations, so it is hoped that other states may be induced to join in the work.

Following naturally upon the projects described above comes the problem of heating the projection room. Information has come to the Sub-Committee that hazardous practices are found in the industry

with regard to heating projection rooms. Instances have been cited wherein open-flame gas heaters have been used.

The subject of heating projection rooms has already been covered by the Projection Practice Committee in the Projection Room Plans, wherein it is stated that "proper provision shall be made for heating projection rooms. The same facilities used for heating the theater should be extended to the projection room."

The regulations of the NFPA for handling nitrocellulose motion picture film state that "artificial heating in any building or room other than a vault in which motion picture film is used, handled or stored, shall be restricted to steam. . . . Heat generating apparatus shall be in a separate room. . . . Ordinary hot-air furnaces are prohibited. Gas, oil, and electric heaters are prohibited in rooms where film is handled or stored."

The problem of heating projection rooms may be approached from two points of view: the ideal or the immediately practical. Writing regulations into the SMPE Projection Room Plans, which aim toward the ideal would lead to connecting the projection room to a central heating plant. In instances where this is not convenient, economic, or practicable provision for local and separate heating of some projection rooms may have to be made. Even when a central heating plant is used, the projection room may require heating before the show to assure fluidity of the oil and grease in the projector, and to make the projection room temperature bearable to the projectionist, especially when the projection room is located on an outside wall of the building in an exposed situation.

This Committee definitely does not recommend the use of gas or oil for any individual heating unit located inside the projection room. This does not mean that gas may not be used for central heating plants using steam, hot water, or hot air, or for any auxiliary heating system in which the heating element is remote from the projection room. This report is not concerned with heating the theater auditorium.

For individual units in the projection room, electric heating is the only alternative. Although the NFPA regulations prohibit the use of electric heaters, this regulation was written in 1931, at which time no satisfactory electric heaters were available. Under no circumstances does the Committee recognize as suitable for projection room use the old conventional type of electric heater, or any other kind of electric heater having exposed heating elements. For any type of

individual electric heater that may be used, the heating element should be completely enclosed and this entire heating assembly and any blower or fan should be enclosed within a protective housing. The temperature of the outside surfaces of this housing should never rise above 115°F. This may require, in the design of the unit, provision for automatically shutting down the unit in case of a rise of temperature above this value or failure of the blower. The protective housing shall be so constructed that no pieces of scrap film or the like may be able to enter through any openings or louvers provided to permit the exit of heated air or the entrance of cool air. The top of the casing should be made to slope or be rounded so that it can not be used as a shelf.

The heating unit (and blower) must conform in electrical design, wiring, installation, and circuit connections, to the requirements of the National Electrical Code.

The Sub-Committee on Fire Hazards has investigated the portable heating equipment available on the market and has found at least one portable electric heater designed and constructed in such fashion as to fulfill substantially all these requirements. The heater is available in several sizes, from 1 kw up, and has two degrees of heating—that is, provision is made for delivering heated air at a temperature of either 45° or 60°F above the ambient room temperature.

MISCELLANEOUS ACTIVITIES

Other Sub-Committees of the Projection Practice Committee are engaged in projects not yet carried to the point where definite reports may be made. The Committee on Projector Output and Screen Illumination has done considerable work on methods and devices for measuring the light incident upon projection screens and reflected therefrom. The measurement of the incident light does not present any problem, in view of the fact that there is available on the market a simple, inexpensive light-meter with a built-in color-filter for simulating visual response to color.

The problem of measuring reflected light in a convenient, inexpensive, and simple way with equipment not requiring highly trained specialists, has not yet been solved. The Committee is investigating the problem further and hopes to be able to report more definitely at the next Convention.

The work of the Sub-Committee on the Power Survey, described in the previous report of the Committee, published in the July, 1939,

issue of the JOURNAL, is proceeding satisfactorily, and the Sub-Committee reports that approximately 600 of the questionnaires have been returned. The purpose of this study is to break down into its components the total electric power used in motion picture theaters, so as to determine the average or representative operating conditions in theaters of various seating capacities and equipped with various types of projection apparatus. The work has about reached the stage where analysis of the data may be undertaken and it is hoped that a comprehensive report may be available by the time of the next Convention.

The Sub-Committee on Screen Border Illumination is investigating several methods of screen border lighting, some of which has received practical demonstrations in motion picture theaters, and one of which is in current use. Material on this subject for a possible future report is in the course of preparation.

	H. RUBIN, <i>Chairman</i>	
T. C. BARROWS	A. N. GOLDSMITH	E. R. MORIN
A. A. COOK	A. GOODMAN	M. D. O'BRIEN
C. C. DASH	H. GRIFFIN	F. H. RICHARDSON
J. K. ELDERKIN	S. HARRIS	B. SCHLANGER
R. R. FRENCH	J. J. HOPKINS	C. M. TUTTLE
E. R. GEIB	D. E. HYNDMAN	V. A. WELMAN
M. GESSIN	J. J. KOHLER	A. T. WILLIAMS
	P. J. LARSEN	

DISCUSSION

DR. GOLDSMITH: You will notice that the Projection Practice Committee has conducted extensive surveys to secure data of various sorts relative to theaters located throughout the United States, to assemble and correlate these data, and to study and analyze them in order that any exhibitor will be in a position to determine whether his theater corresponds to average practice, better than average, or worse than average theatrical practice. It is hoped that such information will be of help not only to the exhibitors in determining the technical or economic correctness of their present practice, but also to the architects of future theaters; and that it may in time serve as at least a partial guide in the design of theaters of more economic, practical, and attractive construction.

I may add that there have appeared before the Committee from time to time, and at its invitation, individuals who have presented on behalf of their companies or themselves pieces of equipment (such as heaters, measuring instruments, photometers, and the like), in order that the Committee might consider and study these. The Committee, of course, takes no part in any commercial issues but it does technically analyze devices and methods and consider their practicability.

FUTURE DEVELOPMENT IN THE FIELD OF THE PROJECTIONIST*

ALFRED N. GOLDSMITH**

Summary.—The highly diversified activities required for the production of a motion picture find their effective culmination in the work of the theater projectionist. The unusually concentrated value embodied in the reels of film corresponding to a feature picture can be brought to the theater audience and made the basis for commercial returns only through the activities of the projectionist.

Nevertheless the public is little aware of what goes on in the projection room.

The projectionist is in part compensated by the likely stability of his activities. His present position in the theater is important. Future developments in the motion picture field, such as three-dimensional sound, wider use of color, and the like, will make his work even more important. The possible inclusion of television projection in theater programs will require his mastery of the new field which is sufficiently similar to his present activities in its broad outline to enable its handling by the theater projectionist.

It has seemed well in the past that the Society of Motion Picture Engineers should wisely devote close attention of an appropriate technical committee to the problems of motion picture projection. This task has in fact been ably accomplished by the Projection Practice Committee which has effectively considered the numerous devices, arrangements, and procedures which are involved in theater projection. It is appropriate at this point to comment on the activities of the projectionist himself, since good equipment alone is not a complete answer to all projection questions.

The position of the projectionist in the motion picture field is rather a peculiar one. He is taken for granted by practically everybody and it is calmly assumed that his difficult job will be done—and done well. The producer, the distributor, the exhibitor, and the audience alike take it for granted that the picture and sound will be delivered satisfactorily and that “the show will go on.” In a way, this is a high compliment. If a job is usually done so thoroughly

* Presented at the 1939 Fall Meeting at New York, N. Y.; received October 10, 1939.

** Past-President, SMPE; Past-President, IRE; Consulting Engineer, New York, N. Y.

and well that it becomes almost a routine matter and that everybody expects it to be satisfactory, it is a tribute to the care and consistent effort of the projectionist.

Yet I think that this attitude fails to appreciate the importance of the projectionist in the motion picture set-up. We hear all about the glamorous stars in Hollywood, but every bit of this glamor has to pass through less than a square inch of film gate to reach the audience. We are impressed by the elaborate stage sets and studio equipment on the West Coast, but it is the projectionist who delivers the results through the projection room port. Millions of dollars and years of time of many people may be spent on a single feature film. Authors, writers, actors, directors, producers, cameramen, sound recordists, electricians, and a host of other studio personnel, as well as the laboratory and exchange workers may be required to deliver the feature film to the theater. And then, the projectionist must "deliver the goods" or take the consequences without acceptance of excuses. It is curious that most other workers in the industry occasionally receive public notice and praise. There are few occasions on which the projectionist receives public recognition or acclaim. Yet it would be well if the public understood that they meet the widespread skill of the projectionist when they see good pictures, even though the projectionist quietly does his job back of the scenes.

A modern projection room from which black-and-white or color pictures and sound are projected is a place full of complicated equipment which requires skillful handling. The alert and capable projectionist of today has to know a lot more about pictures and sound than his predecessor of twenty-five years ago. Furthermore, the projectionist of tomorrow will have to know still more. Looming on the horizon are increases in the use of color pictures which mean, in turn, a brighter and whiter screen with careful control of illumination intensity and color. New types of projection, of screens, and of theater design are all in the offing. Three-dimensional sound—where the sound of the speaker appears to follow him around the screen—is one of our prospects. And, most startling of all, television projection is closer than "around the corner."

Speaking of television, it is interesting to know that in England television pictures as large as 15 × 20 feet are projected on the theater screen. While these pictures do not have either the full brightness or detail of present motion pictures of the same size, yet they have been good enough to fill large theaters repeatedly and to

induce the theater chains to order the installation of substantial numbers of such television theater equipments of various types.

There are several fundamentally different sorts of television projectors for theaters, and no one is sure just what will constitute "standard" theater equipment in that field 5 or 10 years from now. However, it is reasonably certain that enterprising showmen will find timely and entertaining material suitable for theater presentation and that mixed film and television programs will gradually be accepted in the theater field.

I regard this as one of the finest and most encouraging prospects which the projectionist faces. The optical principles governing television projection may differ in detail from those used in film projection, but broadly they are quite similar. The sound reproduction in the television program is of course carried out by amplifiers and loud speakers as at present. The enterprising and up-to-date projectionist can master television projection as readily as he did film projection and can make himself just as invaluable in the theaters of the future as he is in the theaters of today. The projectionists and their organizations might well study this new field and keep up to date on it so that, as it finds a place in the theater, they may be prepared to assume an important position in the television field as well.

There are some lines of work where a man today might feel puzzled or worried as to his future. He might wonder whether there was going to be a demand for the commodity or services which he produces. Or he might doubt whether his field would hold its own against some new competitor. The projectionist of today is peculiarly fortunate. If he is energetic and determined in the future he will be free from the dangers I have just mentioned. His field is an expanding field, with new opportunities and obligations. He and the engineers should draw closer to each other in an association of substantial help to each group. Thus the projectionist will, in all likelihood hold the same key positions in the theaters of the future as he does in those of today.

PROJECTION ROOM PLANNING FOR SAFETY*

E. R. MORIN**

Summary.—A brief account of the work of the State of Connecticut with respect to the abatement of fire and other hazards incident to the presentation of motion pictures. A model projection room, the design of which has been based upon the experience of the State of Connecticut in the motion picture field, is described and illustrated.

The purpose of this paper is to relate the experience of the Department of State Police of the State of Connecticut with respect to the abatement of fire and panic hazards incident to the presentation of motion pictures.

Progress and success in the control of hazards can result only from close observation and the experience gained thereby, and it has been found that the closer the observation and the longer the experience, the better the chances are for improvement.

By virtue of legislation passed in 1909 the Department was given control of the subject and at that time both the industry and the equipment were in a primitive stage. The theaters were mostly superannuated "opera houses" and so-called moving picture theaters of the shooting gallery type set up in vacant stores. Film fires were expected and these expectations were promptly realized, all of which was food for thought as well as an excuse for high insurance rates.

Conservative men were assigned to the enforcement of the law, and by diligent study of the problems and firm administration of the rules, they gained and maintained the respect of both the theater owners, underwriters, architects, and contractors.

Material savings were made but in general nothing of great importance occurred until 1921 when there was a serious catastrophe caused by a stage fire in a combination vaudeville and picture house. This fire did not originate from picture equipment but it stirred up the population of the state relative to safety in places of public assembly and it gave the state police the opportunity of making and enforcing

* Presented at the 1939 Fall Meeting at New York, N. Y.; received October 6, 1939.

** Department of State Police, Hartford, Conn.

stronger and better regulations covering all places where motion pictures were exhibited. Since that time there has not been a fatality or a large fire loss that could be charged to the use of film, and since that time state policemen assigned to inspection of theaters have

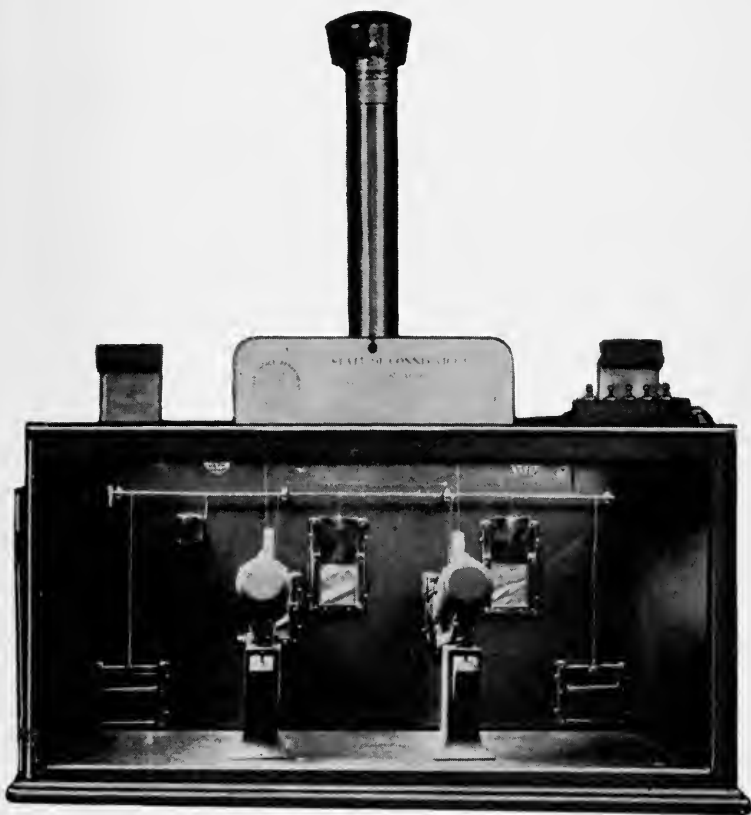

FIG. 1. Complete model of projection room (width about two feet) viewed from the rear.

been relieved from all other duties and been required to make intensive study of both building and projection.

The Department's next great opportunity was ten years ago when everybody in the picture business went in for sound or went out of business. This revolution in projection necessitated larger projec-

tion rooms and the Department sold the idea of building not only larger but better projection rooms.

When a new theater is to be built or an old one reconstructed we supply the architect with photographic copies of plans and illustrations of how a model projection room should be designed and equipped. In connection with this the Department has recently installed a complete projection room with a small auditorium in our Administration Building.

The Department has maintained membership in the Society of Motion Picture Engineers, the National Fire Protection Association,



FIG. 2. Front view of model, showing ports.

the New England Building Inspectors Association, the New England Fire Chiefs' Association, and has worked in close coöperation with the underwriting organizations who pass on special hazards. Insurance rates are or ought to be merely a reflection of the hazards involved, and the abatement of hazards either does or should mean a reduction in insurance premiums. We expect to make the exhibition of motion pictures in Connecticut so safe that theaters will be taken out of the special hazard class.

Much has been learned about buildings and projection through our association with organizations, particularly the Society of Motion

Picture Engineers which the Department joined in 1936, and its representative has been an active member of the Projection Practice Committee. The Department has found this engineering body very helpful incoördinating with them in several of their technical problems. The real school for learning is the careful observation incident to our day-to-day examination of theaters in action.

Out of our experience in these matters it was determined that the way to cope with burning film was to provide absolutely fireproof projection rooms built of masonry, so that in the event a careless projectionist, acting in error, should have a few thousand feet of film exposed, it might be burned without loss or panic outside the projection room. Our safety devices are automatic in action, and about all the projectionist has to do is to get out of the projection room and see that the door is closed.

Examining these activities in detail I bring to your attention the following:

About ten years ago we experienced an explosion in one of our projection rooms. The result of our investigation proved one thing: that we did not have the proper ventilation. We found that the 10-inch indirect-type flue did not give us a natural circulation of air due to stack resistance. Furthermore, the conventional fan used in that period was not sufficient to exhaust the smoke and gases which were generated from burning film. We learned also that a vent going through the rear or side wall of a projection room was subject to back-drafts, depending upon weather conditions. We then conducted experiments with vertical flues, eliminating elbows, increasing the diameter from 10 to 18 inches, and installing a bucket-blade fan instead of a flat-blade fan. A further survey disclosed that the numerous types of hoods used on these flues offered considerable resistance which cut down the desired natural circulation of air. We then investigated several types of hoods until we found the type which offered the least amount of resistance. Over a period of ten years this combination has proved very satisfactory.

Our next step led us to the conclusion that, regardless of improved ventilation, less damage would accrue if the booths were larger. Moving in that direction, we specified projection rooms with a minimum depth of 12 feet and a width of 16 feet and a height of not less than 8 feet. One of our primary requirements with respect to size is that no protruding object shall be within 30 inches of the right or rear of any projector.

We also felt that the old conventional type motion picture booth, consisting of asbestos board and angle-iron, did not afford the necessary fire-resisting segregation from the auditorium. Furthermore, this type of booth, with the advent of sound, permitted the noises of the projection room to be transmitted to the auditorium.

Considering the above facts, we decided on a masonry type of projection room, but in so doing we were confronted with another problem. We found that quite a number of the older theaters were

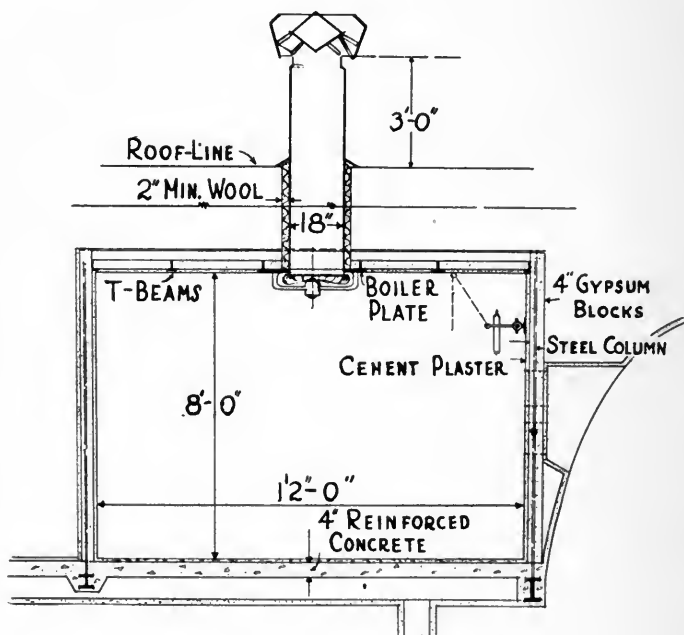

FIG. 3. Cross-section of projection room.

not structurally designed to receive the added weight. We then had to design a projection room eliminating as much weight as possible but without jeopardizing any of the safety factors. This was accomplished by erecting a masonry or steel foundation with a steel frame, 4-inch reinforced concrete floor, 4-inch gypsum-block walls and ceiling, with hard plaster inside and a standard or acoustic plaster outside, using a fire-door equipped with a door check but no latch, and permitting only a dead lock. The reasons for this latter feature are, first, in the event of a fire, if the pressure in the projection room should

reach the explosion point, the door being the weakest point, should open and close automatically; and, second, that should the hands and face of the projectionist be burned he should be able quickly to leave the projection room without having to fumble about for the door latch.

In the past it was customary to use a ladder through a trapdoor in the floor or a ladder along the side of the wall to reach the projection room. This practice has been discontinued by permitting only a fire-resistant stairway with the minimum treads of $9\frac{1}{2}$ inches and maximum risers of 8 inches.

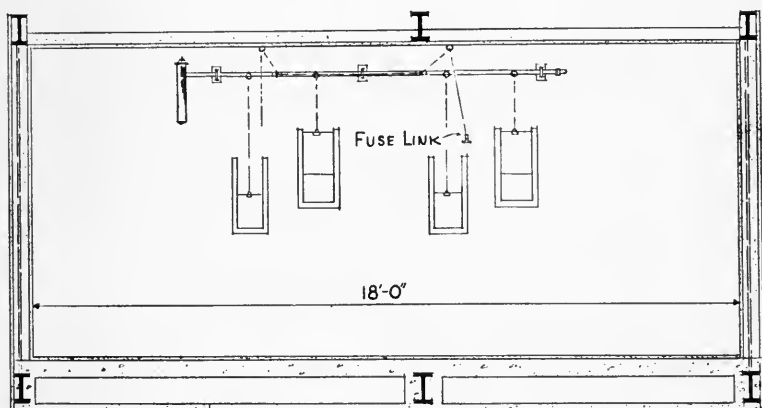

FIG. 4. Front elevation of projection booth.

In the past the port shutters were fastened with string and fuse links along the ceiling. The objection to this was that a considerable flame was necessary before the shutters would operate. The manual release was either at the rear of the projection room or close to the door. We found that this condition could be improved upon. We proposed speeding up the closing of the shutters by erecting a rod over the shutters with pins in the rod to which the shutters are attached by means of a cord and rings. Also opposite each projector there is provided a protruding arm with an eye in each end through which an endless cord is run from one projector to the other and attached to fuse links which, in turn, are attached to the rear part of the upper magazine near the door latch. By so doing the fuse link is placed as nearly as possible to the point where the fire would probably originate.

Also it should be recalled that the projectionist is at hand to shut his machines down and he can release the fuse link and drop the shutters without going to another station.

In the event of a fire the projectionist is supposed to shut down his machines, close the port shutters, turn on the house lights, and see that the projection room exhaust fan is in operation. Through past experience we have discovered that in some cases the projectionist did not turn on the house lights or the projection room ex-

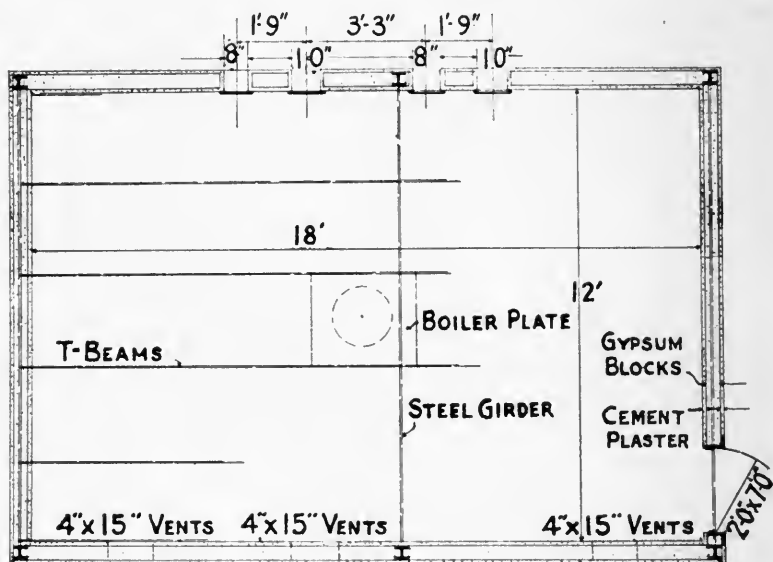

FIG. 5. Reflected ceiling plan of projection room.

haust fan. To overcome this difficulty the Department designed a switch, the details of which were published in the May, 1939, issue of the Society's JOURNAL.

We also encountered difficulty with the conventional type of film cabinets. With the coöperation of an equipment manufacturer these cabinets have been improved by inserting a heat-resisting material which completely fills the air-space between the compartments and the cover. This prevented the external heat from burning film in the vicinity or adjacent to the cabinet and from igniting films in the cabinet.

In recent years we have encountered a new difficulty with the installation of refrigeration and air-conditioning equipment. First, in the event of a fire and the failure of the port shutters to close, and the breaking of the glass covering them, the ports would become exhausts due to the auditorium ventilation. This possible condition was overcome by connecting the auditorium ventilation to the emergency switch mentioned above. Second, the conventional type of intake ventilation near the floor became an exhaust instead of an intake. This condition is now under survey, and these intakes are being taken from the outside. We have received some objections from the projectionists to this particular method; in particular, they have objected because the projection room would be too cool in the winter. We are at the present experimenting to find a solution for this condition.

The Department, realizing that this is a highly technical subject, has purchased numerous instruments to enable this survey to be conducted in the proper manner. Projection room ventilation is a large subject in itself, and as the Department survey is not complete I shall not here attempt to discuss it further.

Our records show that the majority of our film fires have been caused by faulty patches. Our method of overcoming this difficulty is by insisting that all projection rooms be equipped with a mechanical film splicer.

The Department has been successful in obtaining from the New England Insurance Rating Bureau the following exemption, a section of which is here quoted: "That based upon the motion picture booths constructed and protected in accordance with your requirements we are agreed to omitting automatic sprinkler protection from inside the booth. Furthermore, we desire to go on record as recommending that the soda and acid chemical extinguishers be placed immediately outside of the booth rather than inside."

In conclusion, three important results have been accomplished: first, greatest safety for all concerned; second, guarding the health and convenience of the projectionist; and, third, better working conditions, which always lead to a better show for the patrons.

DISCUSSION

MR. EDWARDS: This is one of the most practical reports we have had in a long time; an example of a State coöperating with the Society (and I think it is the only State so far that does so), employing the same degree of investigation as we do here.

MR. RICHARDSON: In many projection rooms the fuses are placed 6 or 8 feet from the possible source of fire. I have proposed that a film link be so situated that any fire occurring in the projector mechanism or at the rewinder would almost instantly strike the link and sever it. Do you think the metallic fuse serves the purpose equally well?

MR. MORIN: I think it does. We do not depend wholly upon the automatic fuse. By placing the control right next to the projectionist, it is very easy for him to trip it and throw off the motor and lamp switches in one operation. Years ago I used a film, but the film becomes brittle with age, and if it is not changed occasionally the shutter may drop when you do not want it to drop.

MR. PATENT: The projectionist may not be at the right spot at the moment of the fire, to operate the controls instantly. I have in mind an electrical release, which could be operated from any point desired.

MR. MORIN: We do not wish to make things more complicated, but rather to make them as simple and practicable as possible. The State of Connecticut requires that the projectionist stay close to his projector, so it should not be necessary to have additional gadgets.

THE PROJECTIONIST'S PART IN MAINTENANCE AND SERVICING*

J. R. PRATER**

Summary.—It is the duty of the projectionist to see that all projection equipment is kept in condition to give excellent service dependably and efficiently. It is impossible to accomplish these results by depending upon memory alone. The projectionist must establish and keep written records of all necessary maintenance data. He must follow a written schedule in making inspections and in doing maintenance work. He must establish a reliable system for checking and ordering supplies and spare parts at regular intervals.

The projectionist should do as much of actual service work as his knowledge, ability, tools, and available test equipment will permit. At least nine-tenths of trouble shooting should be done before any trouble exists. He should obtain detailed drawings of internal and installation wiring of all electrical equipment, besides identifying the points at which tests may be made. He should prepare a written outline of all tests that could be made if various troubles existed. Then he should actually make all possible tests in advance, wherever possible, without causing damage, by deliberately creating the trouble and then correcting it. He should immediately record the exact results of each test in the written outline. In this way, simple tests may serve as well as or better than elaborate ones.

The professional service engineer with special test equipment is a necessity to the finer and more difficult parts of modern servicing, but the projectionist who makes the best of what resources he has can also do a very valuable part of the job.

Motion picture projection equipment requires a considerable amount of maintenance and servicing in order that it may function at all. However, the purpose of good maintenance reaches far beyond this minimum. When patrons pay admission to a theater the show must go on. If they are to return again and again the show must be not only good in itself, but also it must be well presented. Therefore dependability of equipment and excellence of results they produce are first considerations. At the same time it must be remembered that the theater is a business that must support itself and show profit in order to succeed. Therefore its equipment must be purchased, installed, maintained, and operated without unnecessary expense.

* Presented at the 1939 Fall Meeting at New York N. Y.; received August 30, 1939.

** Congress Theater, Palouse, Wash.

First-cost and installation expense must be as low as possible consistent with good results. After that, every part of every equipment must be made to perform its duty faithfully and well and for the longest possible space of time, though in every instance necessary adjustments or replacements must be made *before* serious trouble or complete failure occurs. These are often conflicting requirements, and the following suggestions will serve a very useful purpose if they merely assist in arriving at a happy medium:

All real projectionists would rather do good work than bad, but many fail to get started in the right way. Equipment maintenance is a splendid example, because establishing a system which will make it possible for them to do a better job of taking care of all the projection equipment entails a bit of extra work. However, once such a maintenance system is started and adjusted to fit the needs of the individual projection room, the projectionist's regular duties can be performed so much better and with so much less effort that very soon an actual saving in work will result.

No projectionist, regardless of his ability, can keep in his head all the data necessary to good maintenance of all the various equipments under his care. Neither can any one man depend upon being immediately available at all times when such data may be needed. It is therefore absolutely necessary to good maintenance that complete written records be kept in the projection room.

A few theaters, mostly in the *de luxe* class, already keep some sort of written records. The average small house—the very ones that need an efficient system the most because equipment is less reliable and operating budgets are strictly limited—usually has no records at all.

Because every theater has different kinds and amounts of equipment the most practicable way of starting such records is in loose-leaf form. With reasonably careful handling, good loose-leaf books can be made to last for years, but if desired the records can be transferred to permanently bound books as soon as the system has been properly established and adjusted to fit the individual projection room. In any case it is very important to provide a convenient place to keep the record books, and to see that they are always kept there when not actually in use.

Before we can keep records of equipment units and parts we must be able to identify each part throughout its entire useful life. Where there are two or more duplicate units such as projectors, rectifiers,

amplifying channels, *etc.*, each should be permanently numbered. In addition, individual parts or assemblies including all spares that may be transferred from one unit to another during their useful lives, such as, for example, intermittent units, photocells, amplifier tubes, and so on, should be individually numbered.

Now, taking each large unit separately, write in the record book all available information that may later prove valuable for reference. Use the first sheet for general data concerning the unit as a whole. Start a new sheet for each part or small assembly, leaving plenty of blank space for future entries in the case of parts subject to wear or deterioration. The loose-leaf binder will permit additional sheets to be added for unexpected future needs.

As an example, under "Projector No. 1" place the date installed, total cost, names of dealer and installation engineer, the nature and cost of any known replacements or service since installation, date of present inspection, and general working condition. On the next page list the upper magazine, giving the date of inspection, present condition of individual parts such as door, hinges, and latch, observation windows, spindle, key, bearing, friction clutch, valve, and all valve rollers. Another page may be devoted to the upper feed-sprocket, its stripper, shaft, bearing, and gear. The entire projector is thus divided into small assemblies or closely associated groups of parts. The same procedure is followed for Projector No. 2, and so on for a all other equipment. This will require some time, but when it is done, we have a foundation of the entire maintenance system.

Keeping all projection equipment in condition to give excellent and reliable service requires that every part shall receive attention as often as required. This amounts to a very considerable task, so it is also important that unnecessary attention be avoided. Since the expected lives of various parts and units may range from a few minutes to several years, some sort of regular schedule must be followed to insure proper attention. In this case, again, no projectionist can depend on memory alone. A written reminder is necessary, at least for those items requiring attention only occasionally. It is easy enough to remember to inspect carbon trims after each reel; to clean or oil those places requiring the same attention every day. However, it is not so easy to remember when amplifier tubes should be checked, generator bearings oiled, switch contacts cleaned, the screen dusted, and such other important but less frequent jobs. To insure attention to these jobs before trouble occurs and the results as viewed

and heard by the public are injured, the projectionist must follow a written schedule. At first such a schedule can be only a guess at the proper intervals between inspections and attention but corrections can be made whenever they are found necessary until a reliable guide is established. It will usually prove better to distribute the less frequent jobs so that they do not create congestion of work at any one time, always following the same order, so that every job is repeated at the proper interval.

And now for supplies and spare parts. The first requirement is to have a definite and proper place to keep them. Unless there is already such a place, provide it at once, calling on the management for a cabinet, shelves, or whatever is really necessary. Be reasonable about material and do not be reluctant to do some of the work yourself, but do not shirk labor by doing an inferior job. Next, it is necessary to have some reliable means of keeping a sufficient stock of spare parts on hand to care for all ordinary needs, without necessity for ordering each item separately at the last minute. A good plan is to keep a "Want List." Whenever routine inspection reveals that certain parts will need replacing within the next month or two record them on the "Want List." Make a written estimate of what supplies and spare parts should be regularly kept on hand. For each item estimate the quantity you may reasonably expect to need during at least one month, plus ample time to obtain replacements. At the beginning of each new month, compare this estimate with the actual stock on hand, and add to the "Want List" everything necessary for another month's run.

Immediately turn this list in to the manager. It is a splendid policy to have him sign a duplicate copy to be kept in the projection room. This copy may well be made on a loose-leaf sheet that can be immediately put into the record book binder. This protects both the projection room and the projectionist. It enables the manager to order everything necessary for a normal month's operation at one time. This policy will not often require any added investment for the theater, since practically all business accounts may be paid the month following the order.

With a complete system of this kind once established and adjusted to fit the individual projection room, the projectionist's mind is relieved of remembering what has been done, what needs to be done at once, and what can safely be left until tomorrow or next week. He can have confidence in his equipment; he can take pride in how well

and how efficiently it performs. His mind is free to concentrate on the actual performance of his duties.

For some reason, projectionists too often regard service work of any kind as entirely out of their line. No doubt lack of knowledge, ability, and tools, or the plain desire to avoid are often factors. The finer points of modern sound servicing really have outgrown the resources of the projection room and the projectionist. As one very able sound engineer has put it, "Efficient, fast-moving sound service required by conditions today calls for more than a competent inspector with a voltmeter and an educated 'nose for trouble.'" True enough, the entire job can no longer be done by the projectionist alone, especially in first class theaters. However, even where a service engineer makes regular calls to the theater and is readily available in any emergency, the projectionist still can and should do a large and important part of service work; not the finer points requiring elaborate test equipment and special training, but the fundamental work which is still much the same as it has always been. Then, too, he can and should be more familiar with the arrangement, wiring, and individual peculiarities of his own installation than it is possible for anyone else to be.

Properly kept maintenance records of the sort previously discussed are the backbone of good servicing. They provide most of the information necessary for discovering and correcting weaknesses before they actually develop into trouble. The remaining part of servicing concerns locating and correcting trouble that happens unexpectedly. In other words, "trouble-shooting."

We usually think of this job as beginning in a wild scramble when the show stops or has to be stopped during a performance. Indeed, that has been the usual procedure in most projection rooms, and it is nothing to be proud of. If the show has been restored quickly by such procedure it has been purely a matter of luck.

At least nine-tenths of good trouble-shooting should be done before trouble becomes apparent in results. The first requirement is to know exactly where each electrical circuit originates and ends; through which fuse blocks, switches, terminal strips, junction boxes, and equipment parts it passes; what voltage and amperage it should carry; whether a-c or d-c; and if d-c, the polarity of each wire. As much as possible of this information should be plainly written on a label or tag which is then permanently attached to the equipment or to the wires themselves at every point where they can be reached

conveniently for testing. In addition, drawings of the internal wiring of each piece of equipment should be obtained from its manufacturer, unless already on hand. Always check, or have the engineer check such drawings with the actual equipment and wiring, and immediately make any changes necessary. Then either attach the drawings permanently to some convenient part of the equipment they illustrate, or record them in the maintenance record book.

The next step is one that should be obvious to anyone who is even remotely connected with a theater. We all know that for any performance to go on smoothly it must be rehearsed, or at least carefully planned in advance. If the performance of trouble-shooting is to go forward swiftly and efficiently, it must also be rehearsed and planned before actual trouble is expected.

Projection equipment, and especially its installation, varies too widely for any general outline to be entirely satisfactory. All the information necessary to locating and correcting (assuming that it be possible) any trouble the projectionist is likely to encounter is easily available to him in manufacturers' instruction books, good textbooks and magazines, or from the service engineer. Even detailed step-by-step charts of exactly what to do in the most logical order of procedure for almost every known type of trouble in the entire theater sound system have been published, both in magazine and in textbook form.

The duty of the projectionist, or at least of the chief projectionist of each theater, is to use this material as a reliable guide, and to construct a similar written outline covering everything he can do in his own individual case, but nothing more. The next job, and a most important one, is to go over his entire installation of equipment very thoroughly step by step, actually making every possible test that he could make if trouble existed. In fact, whenever possible, without causing damage, *he should deliberately create the trouble and then correct it.* Since many of the possible troubles may never occur, or if so only at infrequent intervals, it is impossible to remember all the details of each test. Therefore it is necessary to combine with the outline a written record of the exact results obtained in each case with the actual test equipment available to the projectionist. This is very important, because his methods and test equipment may give entirely different results from those of an engineer, but as long as he can repeat the exact test in the future and compare the results with those of the same test made when the equipment in question was in normal

working order, he can usually tell good from bad—and that is usually all he needs to know. For example, he can determine accurately at any time whether or not the contact-pressure of each brush in a motor-generator set is correct, with only a rubber band and a weight of any kind equivalent to the proper contact-pressure, provided he has prepared the weight when he knew the brush-pressure to be correct. Similarly, he can show his manager how badly the screen has deteriorated by comparing visually its present reflection power with a sample of the same material that has been carefully wrapped and stored since the screen was new—probably more convincingly than a competent engineer with a similar comparison of light-meter readings could do. The projectionist can take all his amplifier tubes, including spares, to the local supply dealer for testing, and can record the meter reading obtained for each tube. Even though the readings may be calibrated in numbers that mean nothing except varying degrees of excellence or the lack thereof, they provide a reasonably satisfactory means of choosing between good and bad tubes, as well as of matching them in pairs for use in half-wave rectifiers or push-pull amplifier stages.

The projectionist who keeps accurate written records as above suggested, and who makes all possible tests and emergency hook-ups, both mechanical and electrical, while he knows his equipment is in good working order, will seldom encounter a breakdown that he can neither correct nor side-step with a temporary repair until replacements or service can be obtained. Even when he has exhausted his own resources without success and must send for an engineer, he can make preparations that may save valuable minutes when help arrives, especially if there is any chance of making repairs soon enough to save dismissing the audience. For instance, if the projectionist has definitely located a faulty unit, he can remove it and be ready to install the new one as soon as it arrives. If further tests must be made, he can remove any panel covers or parts that will prevent or obstruct free access to points that must be reached, get out all available drawings, blueprints, and reference data associated with the trouble and look up any specific information he can that the engineer may need upon his arrival. If a soldering iron will be needed the projectionist should have it hot and ready a few minutes before the engineer is expected.

It is granted, without argument, that professional service by a competent engineer with elaborate test-equipment is a necessity in ob-

taining the last bit of perfection in screen results from modern projection equipment, as well as in locating and correcting the more difficult cases of trouble. But in the thousands of theaters where such service is a luxury that can be enjoyed only at rare intervals, as well as in the thousands more where it takes hours or even days to obtain replacements or outside service, the patrons who pay their admission fees are entitled to at least a reasonably excellent performance. The responsibility of delivering that performance rests largely and primarily in the hands of the projectionist. The results he produces depend less upon how elaborate his resources are than upon how well he uses those he has.

DELIVERING LABORATORY RESULTS TO THEATER PATRONS

Laboratory technicians of widely varying kinds have combined their efforts to give us the motion picture as it is today. The results of their efforts may be seen in almost every branch of the entire motion picture industry.

Photography has been developed tremendously. The very film upon which the pictures are made has been changed from a brittle, yellowish substance to one that is tough, pliable, and almost wholly colorless. Early photographic emulsions capable of producing pictures only slightly better than silhouettes, and even then only under the most favorable conditions, have been replaced with dozens of special emulsions, each capable of doing a certain difficult job. Numerous color processes have been combined with, or added to, these new films and emulsions. Camera mechanisms and lenses have been improved and redesigned to take full advantage of the almost endless possibilities furnished by modern raw film stocks. Developing solutions and processing methods have kept in step. Without the single process of "duping" alone, modern quantity production would be impossible.

Sound recording for motion pictures has undergone similar extensive development and improvement. Disk records with their needle scratch and synchronization problems have been replaced by direct recording on the film itself. Slowly but steadily the fidelity and frequency response of sound recording has been improved, while undesirable noises of all kinds have been almost eliminated. Re-recording has solved difficult editing problems. Uniform standards have been agreed upon.

Projection once consisted solely in getting an image of any kind on

the screen. Lenses were slow and poorly corrected, intermittent movements were inaccurate, mechanisms as a whole afforded little or no protection to the film, often inflicting serious damage themselves. Projection speed varied from half to twice normal camera speed according to the projectionists' individual fancy or to a more or less unreasonable performance schedule. Light-sources were weak, and their optical systems could deliver to the aperture only a small portion of what light was produced. Modern projectors and their high-intensity arc lamps are capable of delivering to the screen an almost rock-steady, sharply defined, undistorted, and brilliantly illuminated image at a projection speed exactly equal to normal camera speed. More than that, the job can now be done efficiently, dependably, safely, and with a very minimum of wear on the film.

Sound reproduction has followed closely behind the advances made in recording. It has grown from the rank of a mere novelty to that of an absolute necessity to theatrical motion pictures. Equipment and methods have been improved steadily, and at the same time simplified, until even the smallest theater can now reproduce any sound from a whisper to a concert by a full symphony orchestra with remarkable naturalness.

All these developments and refinement that make the motion picture of today a technical marvel of almost perfection in every detail have come from laboratories. But research, experimentation, special equipment, and the services of thousands of highly trained technicians have cost a tremendous amount of money. Without that money, practically none of this development would have been possible. The motion picture would still be a crude novelty.

Whence has all this money come? It has come from the patrons who have paid their admission fees to motion picture theaters. Not only the money for improvement, but also that for production, distribution, and exhibition, as well as what is wasted or lost along the way, has come from the theater box-office ever since the day of the first "nickelodeon." The total revenue from all other sources combined is but a drop in the bucket.

Between what the laboratory has made possible and what the paying customer actually sees and hears in the theater, there is a gap filled by the projectionist. The final success or failure of the efforts of the entire industry depends largely upon how well or how poorly the projectionist does his work. It is true that if he puts on the show at all, some of the benefits of the careful work already done by tech-

nicians will reach the patrons. However, it is also true that the finer those benefits may be the more easily they can be lost before reaching their final goal. We know, of course, that no projectionist can produce better results than the films and equipment furnished him are capable of, but let us suppose a new print is to be projected with modern equipment in first-class mechanical condition. Here are a few items that would depend even then upon the projectionist:

An error of a few thousandths of an inch in focusing the projection lens, or a fingerprint or smear of oil on any of its glass surfaces will reduce the finest photography to something definitely displeasing. Too little aperture tension or a tiny bit of dirt or emulsion lodged on the face of the intermittent sprocket will cause the screen image to be unsteady in spite of the fact that the tolerances of the intermittent movement have been held to within one ten-thousandth of an inch. Too much aperture tension will cause unnecessary wear and inflict permanent damage to the film. A slight error in any of the arc-lamp adjustments may reduce screen illumination, create uneven distribution of light, cause unwanted color to appear, allow the light to fluctuate, or even to go out entirely. A tiny bit of lint or dirt obstructing part of the light-beam of the sound optical system may impair sound quality more than the last ten years of work have been able to improve it. The same result may come from an improperly adjusted exciter lamp, or from dirt or oil on sound optical system elements. A small accumulation of wax or dirt on the face of the sound-sprocket or film-drum may introduce enough flutter to make the sound displeasing to even an average listener. Too little volume may rob the sound of intended dramatic effect and naturalness, or make parts of it wholly inaudible. Too much volume may also make certain parts of sound unnatural, and the louder parts distinctly annoying or even painful to many ears. A few runs through oily, dirty projectors and an improperly adjusted rewinder will inflict permanent damage to the film, which will result in blemishes in the screen image and noise in the sound—not only in that theater, but in every theater where that print must be run.

These are but a few of the possible instances in which the results of years of the most careful laboratory work may be destroyed or may fail to reach the theater patrons for whom they were intended, through failure of the projectionist to do his full share of the job. Such failure may be due to many causes, but outstanding among

them is the lack of thorough technical knowledge. This is the very backbone of ability and pride in good workmanship.

Whatever can be done to increase the technical knowledge of the projectionist will benefit the entire motion picture industry just as much as it will the projectionist himself. It is, of course, impossible for the projectionist to know as much about every phase of the work as do the engineers, who usually specialize in some one of the many branches that compose the entire field. The best that may be hoped is that he may be able to understand the fundamentals of all branches, and enough of the newer developments in each to be able to understand and appreciate what the engineers are doing and to cooperate with them to the extent of handling their productions competently.

If the projectionist is to do this and thus deliver laboratory results to his audiences, he must be able to understand if not to speak the language of the laboratory engineer. A spirit of friendly cooperation must exist between them if the final result of their well directed efforts is to attain final maximum success.

POSSIBLE METHODS FOR ENCOURAGING STUDY BY PROJECTIONISTS*

F. H. RICHARDSON**

Summary.—The high importance of expert work in theater projection rooms is stressed. Pride in performance is essential to excellence, and if the status of projection were elevated to a higher plane improvements would result in both picture and sound presentation. The author offers a suggestion concerning the contacts of the Society with the projectionists' organizations.

This paper has been prepared in the hope that its contents may start discussion eventually resulting in greater justice to the splendid equipment made available to theater projection rooms through the efforts of able engineers connected with their planning and construction. It has been prepared in the hope that such discussions may result in better presentation of the product Hollywood delivers to theaters in the form of still photographs successively arranged, accompanied by sound in photographic form, all for the entertainment of countless millions of men, women, and children each day.

While this industry and its various component parts are slowly coming to realize that, if these successive still photographs are to be transformed into an acceptable semblance of the original motions and sounds they represent, great care, coupled with skillful manipulation of the equipment employed, must be applied in theater projection rooms. There still is lack of comprehension of how far we are from securing maximum excellence on theater screens and through loud speakers.

The design engineers have worked wonders in planning and constructing these equipments; yet there is a sad lack of care in their use in the theaters. This is not due entirely to lack of knowledge, as ample information is available to projectionists. Nor is it due to lack of skill, but rather to lack of careful attention and application.

In the theater of today, great and small, well equipped or otherwise, we find a large amount of what can only be termed carelessness.

* Presented at the 1939 Fall Meeting at New York, N. Y.; received October 10, 1939.

** Quigley Publishing Company, New York, N. Y.

We find projectionists little interested in the finer points of their work. We find few cases where the screen image is in the sharpest possible focus. We find the screen poorly illuminated, with not a word of protest from the projection staff. We find great waste of light which might be avoided by care and skillful work on the part of the projectionist. We find sound that might be greatly improved; and so on through a considerable list of remediable faults.

A course of education in technic would remedy much of this, and would be a most effective procedure by the Society. However, that by itself would not be sufficient.

I have visited many theaters in many parts of the country, and have had a unique opportunity to ascertain what is wrong in theater projection rooms. The chief fault is, I should say, a lack of pride on the part of projectionists in the performance of their work as exemplified by the screen and sound. It is a rare thing to come across a projectionist who honestly takes pride in the results of his work.

Perhaps this is the result of the indifference shown toward and the lack of respect exhibited for projection and projectionists through all but a very few of the recent years of our industry's existence. I firmly believe that great improvement would result were the projectionist and his work raised to a higher plane of respect. What can our Society do to assist in such a movement? It might, at its meetings and in its publications, direct attention to the great need of careful, expert coöperation in putting on good motion picture shows. This might tend to raise the respect of the projectionist for his work and arouse his pride in the work. It might be well to contact the IATSE through its international officers and perhaps its conventions, stressing the point that it is the duty of the local unions not only to supply to exhibitors men who are thoroughly competent, but also to check up on their performance and see to it that the best possible results are produced by its members.

It would seem, too, that the exhibitors' organizations might well be contacted by our Society, calling attention to the improvement in results in both picture and sound, and the reduction in cost resulting from employment of men of higher ability possessed of greater respect for and pride in performance. Set up a condition where men and their work are held in high respect, and automatically those men will react favorably. Set up a condition where men and the results of their labor are held in small respect, and there is little chance that excellence of performance will result.

SOME INDUSTRIAL APPLICATIONS OF CURRENT 16-MM SOUND MOTION PICTURE EQUIPMENT*

W. H. OFFENHAUSER, JR., AND F. H. HARGROVE**

Summary.—Sixteen-mm sound motion pictures are potentially one of the most effective means through which industry can develop a broad, cost-cutting communication system within the organization itself.

Many latent applications for internal films exist; the cases in business where the improved transfer of ideas afforded by films can be most profitable are almost unlimited. Several specific instances are cited.

Sixteen-mm equipment is simple, easy to operate, reliable, and economical. With it, a member of the industrial organization who knows his company's products, policies, and structure can readily produce films that are, in every respect, profitable internal communications media.

It is usually a surprise to even those connected with our industry to learn that the virtues of Dewar's Scotch Whiskey were extolled in a business film in 1894.¹ As we look further into the history of films for business purposes, we learn that business films are practically as old as the motion picture itself.

Unfortunately the growth of the business film has not paralleled the growth of the industry. As one writer put it: "The point is, commercial motion pictures are at least 45 years old; yet advertisers still think of them as a new medium. Here is a major medium of expression that has grown, to be sure, but has never grown up. Why?"¹ Many answers to this question have been suggested, a number of which can be traced to the same underlying cause: "Films are regarded at the foot of novelty advertising, below souvenir pencils and paperweights instead of at the top of communications."¹

It should be obvious that any communication medium is particularly fitted to specific classes of intelligence transmission; this principle applies no less to the film than to any other communication medium. As we review the films produced by education and those produced by business, we are struck with the similarity of the aims of

* Presented at the 1939 Fall Meeting at New York, N. Y.; received October 14, 1939.

** The Berndt-Maurer Corp., New York, N. Y.

the two fields and the dissimilarity of the films produced. We are tempted to conclude, if a cryptic summary may be ventured, that business has produced much film and little theory as to how films should be made and used, whereas education has produced much theory and few films in accordance with the established theory. Since the aim of both films is to "put an idea across," it is reasonable for us to extrapolate the experience of one into the field of the other to the mutual benefit of both.

One of the simplest and best reports² on the subject of films for educational purposes is that of the Committee on Intellectual Cooperation of the League of Nations, written in 1924. The findings of this Committee may be considered a reference standard through which the efficiency of instructional films may be gaged. The following is a résumé of the report.

(1) Slides and motion pictures should be used for maximum effectiveness. As a general rule the use of these two adjuncts is not judiciously proportioned, one oftentimes being used to the complete exclusion of the other. We can no doubt agree that the conclusion of fifteen years ago is still a valid one today. Too many projects use but one medium to the complete exclusion of the other.

(2) All objects and scenes that the audience is intended to watch and remember in movement should be shown in movement. Still pictures representing objects and scenes that ought to be seen in movement should be banned as giving a distorted impression of the actual facts. While our films are improving in this regard, we still find countless instances where we photograph stationary objects with a motion picture camera and moving objects with a still camera.

A corollary that may reasonably be added at this point is that all objects and scenes that the audience is intended to watch and remember in sound should be shown in sound. Silent pictures representing objects and scenes that ought to be heard in sound should be banned as giving a distorted impression of the actual facts.

(3) The screen can not displace the personal element; it can to some extent displace printed matter, and it should, in all events, be used in combination with it. The use of the screen in conjunction with text-books and printed matter is still quite undeveloped; its effectiveness when properly used is in the top rank of communication media.

(4) The screen should be used in combination with personal con-

tact in "getting the idea across." It should be used at the location where the salesman or teacher ordinarily operates whenever it is of advantage to do so. It should be possible to repeat the picture several times if necessary; the picture should be definitely constructed in such a manner that it will bear repetition.

Industry has shown a growing tendency to bring the screen to the customer instead of the customer to the screen. This tendency is in the proper direction.

It is not true, however, that films are always constructed in such a manner as to bear repetition, as is particularly necessary in films for instructional purposes. Too often a large number of diverting technical effects such as fancy wipes, dissolves, and the like, have been used in a single reel. Such technical effects do not cover up glaring defects in plot, continuity, and lack of logical presentation that are also usually present. Our technical effects shall aid the story, not make it.

(5) The screen can not be used in the proper manner unless there is very wide distribution of effective yet inexpensive apparatus, so that every user of films can have his own projection equipment. The simplest apparatus to handle will be best, and at the same time there must be no risk of fire. If the screen is to do its proper work the apparatus must quickly become a thing in daily use.

The 16-mm size affords the best means of very wide distribution of effective yet inexpensive apparatus with minimum risk of fire. It is the simplest to handle and makes possible the daily use of the equipment due to its very simplicity and low cost of operation and maintenance. That this is true of equipment for making films as well as of equipment for reproducing films is only now beginning to be appreciated in its broader aspects.

(6) The mode of use of the screen must be improved, having regard to the fact that it can act upon the mind of the spectator:

- (a) By faithful presentation of the subject.
- (b) By the representation of the subject simplified.
- (c) By the representation of the subject in sections.
- (d) By the representation of the subject intensified, magnified, represented, speeded up, slowed down, built up by degrees, or superposed. These different methods must be employed according to a logical scheme, taking into account the subject to be dealt with and the specific character of the audience to which the film is planned to be shown.

"Too often they (the producers) have sold companies on the idea of producing films, not as integrated parts of a well rounded-out program, but as special bits of magic for one-time splurges."¹ Even in the larger efforts it is almost as common for a film to be designed for no particular audience as it is in the case of the film produced by the fly-by-night "Hollywood" director who "has his office in his hat." There is still the feeling among a number of picture purchasers, and to a lesser degree among picture producers, that one magic super-spectacle is better than a large number of modest films each telling its complete part of an integrated story.

It is of utmost importance that the *exhibition* plans for a film be fully completed before the first camera exposes the first foot of film. Maximum effectiveness presumes the gearing of the subject matter of the film to the audience.

(7) The screen is a valuable means of suggestion; it will be used as a time-saver, often a valuable one, in "putting across" all matters that depend largely on visual memory.

Psychologically, the lighted screen in the darkened room compels concentration upon the material presented. It is not only possible to "put across" details of mechanisms and their operation, but also to explain the coördination of the activities of groups that can not in the usual course of events be observed. This field is practically a virgin field for industry.

(8) In order to economize effort and to save expense in making films, and to derive maximum profit from them, it is advisable to decide definitely beforehand to what extent regular photographing and animation are respectively to be used.

Due to the high cost of animation per foot in comparison with regular photographing, animation is used to a much smaller degree than in many cases seems desirable for maximum effectiveness.

If we reëxamine the field of business films as a whole, we are struck with the fact that the external film, in particular, the film developing the customer-sales-organization relationship, has been widely used. The internal business film is less widely used and still less widely heralded. Many organizations that have used both have found that, dollar-for-dollar, the second type usually produces better results wherever it has been tried. The obvious use of the internal film is in sales training, and many organizations have set up photographic departments to make use of the advantages of this type of film.

The well-managed industrial organization is always looking for new opportunities to achieve and maintain competitive advantage. When a unit for the production of internal business films is first organized, its personnel complement is small and its activities few. These few activities are usually related in some manner or other to the selling operation. But when the film production unit gets under way, its scope of activity expands far beyond its original purposes into fields that have little to do with the sales operation *per se*.

An excellent example of this is a recent film produced by the Fisher Body Division of the General Motors Corporation showing how container-packed automobile body parts may be advantageously handled by transportation companies between the manufacturing plant and the assembly plant, to the simultaneous profit of both the transportation companies and the Fisher Body Division. This film was produced wholly within the company organization. While it was necessarily photographed in "catch-as-catch-can" manner, the resultant film tells its story forcefully as well as effectively and needs no technical embellishment whatever to establish the straightforward points of the presentation.

The establishment of such internal motion picture departments in industry is now becoming quite common. Some organizations, such as the Fisher Body Division, in the case just cited, prefer to produce the film completely within the organization. Other organizations, such as the Skelly Oil Company with its salesman-training films, prefer to work out the script and shoot the basic material, leaving the editing and scoring work in the hands of a commercial 16-mm film producer. The proper procedure depends upon the circumstances; each has its respective advantages. The 16-mm industry is prepared to supply not only all the necessary equipment but also all production and other services required for all such needs.

The advantages of 16-mm equipment for internal production purposes hardly need repetition here. In 16-mm production equipment as in projection equipment, relative simplicity, portability, freedom from fire risk, and relatively long operating time per pound of film are already well known. The picture quality and the sound quality may be readily made as good as required. In the case of the sound, for example the quality may readily approach that of 35-mm theater reproduction if desired, as was demonstrated at the last meeting of the Society by J. A. Maurer.³ In most cases such high quality is not required.

The subject matter of internal films does not require treatment by experienced showmen and dramatists; it is best presented in straightforward expository style. Subject matter need not be created and staged; there is an abundance of it to be found in the plants, in the men, and in the routines of the organization.

The ultimate in technical excellence is not required to enable these films to serve their purpose effectively. If the picture is reasonably well exposed and correctly focused it makes little difference that the scene was not lighted by artists. If the sound is natural and understandable, and properly related to the subject, it makes little difference that it is not the masterpiece of a showmanlike mixer-man. In such films the subject matter is of predominant importance.

The all-important qualification of a producer of internal films is an intimate knowledge of the organization for which he intends to produce. He must be thoroughly familiar with its policies, its plans, and its objectives. He must be on a firm footing with the personnel; he must know executives and managers and have their full confidence. Most of all, he must know and understand the various problems existing in the company. Only with qualifications such as these can he expect to make his work appear convincing and authentic.

It would seem difficult to find men answering these requirements anywhere except among the company's seasoned employees. Can such employees become the producers of internal organization films? The answer is definitely "yes"; the required technical ability is readily developed, as anyone familiar with the characteristics of direct 16-mm camera and sound recording equipment can understand. The technic of the medium is, as a general rule, readily acquired by a person who has the other necessary qualifications.

There are two general classifications of business films for internal use: those that convey a message from management to personnel, and those that convey a message from personnel to management. The films in the former group are primarily instructive; they may therefore be expected to follow the usual four-step instructional method of preparation, presentation, application, and examination. Other media of instruction, such as the lecture, the slide-film, and the printed word, should be integrated parts of the instruction method. Since the films in the latter group are primarily informative, the examination step usually is not involved in the presentation. The use of other media of communication such as the lecture, printed

BUSINESS FILMS FOR INTERNAL USE

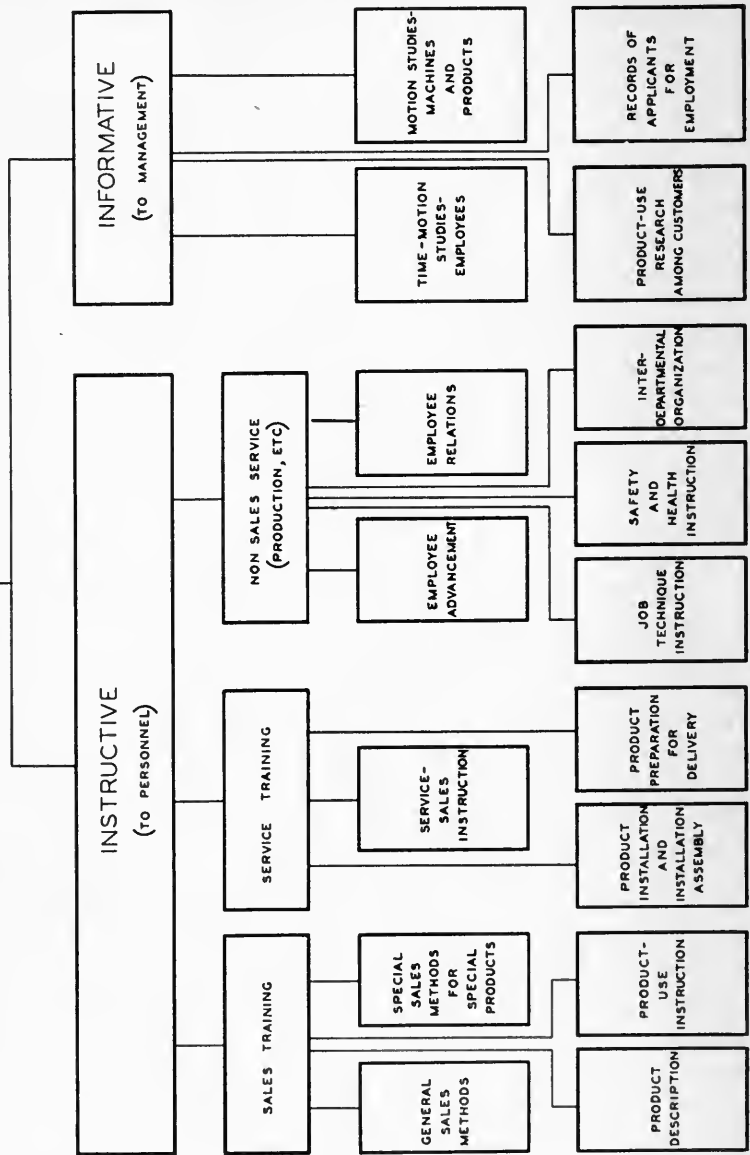

FIG. 1. Classification of business films for internal use.

word, slide-film, and so forth, is also indicated here just as in the case of instructional film.

Fig. 1 shows a general outline of films for internal business use. Certain of the applications shown have been widely used; others are still relatively little developed. Most of the classifications can be readily understood by inspection and need little explanation.

A few notes on some of the lesser understood classifications are indicated at this point. These notes deal with the management-to-personnel films of the non-sales-service group.

Interdepartmental Organization.—In larger organizations particularly, the loss of the personal touch is a morale factor that should engage the attention of every business manager. Specialization makes such demands upon the time of a particular individual that it is not only impracticable but usually also impossible to maintain that desirable form of contact. There are numerous companies today where a film outlining the organization of the company would not only reestablish the personal contact but also depict clearly the personalities of the men performing the various functions in the organization. This type of film can materially aid the *esprit-de-corps* and improve the efficiency of the organization.

Safety Promotion and Health Conservation.—The loss of time and efficiency of personnel due to sickness and accidents is still a major problem to industry. Most industrial plants have safety and health programs, which vary in scope from weekly bulletin board cartoons to elaborate systems including medical service, health furloughs, and other features. In industrial plants particularly, it has been found that motion pictures are the most graphic means of safety and health education. The work that is now being done in connection with safety training in the mining industry is a typical example. The motion picture makes it possible to show clearly all the details of the little items of carelessness that result in an accident.

Job Technic Training.—Job technic training is one of the foremost non-sales uses for internal films. It is not unusual to find that older employees are poor teachers, and, because of possible jealousy of new employees, such older employees may even intentionally pass on instruction that is not of the best. The film admits of standardized instruction into which error through repetition can not creep. This standardized instruction may readily be that of the most efficient method of performing a particular task.

New technics must be acquired by old employees, not only to im-

prove their productivity on old products but also to produce new products. If an employee is left to devise his own technic, time-and-motion study—also best done with motion pictures—will show that he usually develops a definitely inferior technic.

Employee Relations.—Employee relations is a wide subject that takes in practically all matters that improve the feeling of the employee toward his company. It is now recognized as good management practice to do whatever is possible toward making each employee feel that he is important to his company, and that his work makes him an important member of society as well.

The ways in which films can contribute to the improvement of such employee relations are almost limitless. Films can be made that give direct educational treatment to such subjects as the aims and problems of the company as well as the soundness of our traditional economic system. Films can be made to provide entertainment for specific employee groups, catering to their particular tastes. Films can be made of employee outings, athletic events, and social events. Films can be made of a documentary or newsreel type depicting existing technics and dealing with local conditions. Such films may be used for historical purposes or for comparing the employee activities in one plant with those in another. Most executives engaged in personnel work can readily visualize a host of other applications.

Employee Advancement.—In progressive organizations it is a cardinal principle of management that anything that increases the intrinsic value of an employee automatically increases his value to the company. In line with this management principle is the organization principle that a man who fills a particular position should gradually acquire wider and wider experience in the work of the position directly above him. In this manner each man in the organization is progressively relieved of more and more routine work by capable, trained assistants. This condition makes for organization flexibility in that it not only makes possible the replacement of personnel losses resulting from ordinary causes such as sickness and death and the usual labor turnover, but also the replenishment and even expansion of personnel required by market and product expansion, or by emergency causes of whatever nature.

In employee training for advancement, as well as in job technic instruction, the 16-mm sound motion picture finds a logical application. The initial source of basic film material may be film produced for other purposes but edited into an appropriate version, or it may

preferably be a film made especially for the purpose. Inasmuch as employee advancement must ordinarily be carried on outside of regular business hours and in addition to the usual duties and routine of the employee concerned, it is doubly important that a wide range of essentials be covered in the most effective and the most efficient manner. Sound-films offer a means of greatly reducing the time allotments for the presentation of facts without sacrificing the quality of instruction.

In almost every broad generalization concerning films, some notable exceptions to the general rule can usually be found. In the field of training films, one such exception is the work of the Photographic Section of the U. S. Army Signal Corps. In attacking this film problem with its characteristic thoroughness, the Army found that no deviations from the fundamental rules governing training-film production can be tolerated. Each film must be specifically prepared for a particular audience and every effort made to avoid entertainment features or to produce a film suited to what is often called "the general audience." A number of papers^{4,5,6} on the subject of the Army training film program have been presented to our Society and all are worthy of very thorough study by anyone concerned with personnel training. The Army demonstration films shown before our Society prove that the practical development of the training-film has reached an advanced stage quite beyond anything done elsewhere on a scale of appreciable scope.

The second notable exception is best described in an announcement (Feb. 10, 1939) from the Harvard Film Service of the Biological Laboratories of Harvard University, concerning film material for the improvement of reading:

"The Harvard Film Service in coöperation with the Psycho-Educational Clinic, Harvard University, announces a new type of film material for the improvement of reading.

"In brief, these films consist of reading material so presented that successive phrases of the separate lines are exposed rapidly across and down the screen. The film serves as a 'pacer' and the pupil is stimulated to keep up with the rate of exposure. As the training progresses, selections with longer and longer lines are presented thereby gradually increasing the eye span.

"During the first half of the current academic year, these films were tested out in an experiment on a group of slow readers among Harvard

freshmen. The group met for a 45-minute training period three times a week for eight weeks. The results were as follows: at the close of the experiment, the trained group averaged gains of 41 percentiles on a speed-of-reading test (the Minnesota Speed-of-Reading Test for College Students) and of 24 percentiles on a test of accuracy of reading (Whipple's High-School and College Reading Test) in excess of those made by a non-trained control group. When measured in terms of a difference between initial and final eye-movement records, the average gain in rate of reading of the former was 52 per cent. An analysis of these records in terms of individual measures showed that the average number of fixations per line was reduced from 10.8 to 6.5; the average number of regressions from 1.6 to 0.5.

"This material is designed to be run at silent speed (16 frames per second) on any 16-mm projector. It may be used for a single pupil or for a group and requires only a semi-darkened room. Twenty selections averaging 125 feet each, adapted to the senior-high and college levels, together with a teacher's manual and a set of comprehension tests for each film, will be ready for release on March first. . . . Although a smaller number of films may be purchased, the best results will be secured when the complete series for any given level are used. By April first, in time for a two months' training period this year, we shall have ready for release thirty selections for Grades 3 to 5; by next September, a third set for Grades 6 to 9."

Life is daily becoming more complex not only in its social aspects but also in its business aspects. It is imperative that our training methods become more effective from the standpoint of saving time and improving quality of instruction. In addition, training of ever-increasing scope must be made available to an ever-expanding group of our trained citizens. Business has already begun to show an eager interest in the development, and if present indications can be relied upon, it should not be very long before we shall be hearing of the experimental results of applied programs of internal training development such as we now suggest.

REFERENCES

¹ "Camera—Action—Sales," Report to Executives, *Business Week* (May 27, 1939), p. 38.

² SEABURY, WM. M.: "Motion Picture Problems—The Cinema and the League of Nations," p. 248.

³ MAURER, J. A.: "The Present Technical Status of 16-Mm Sound-Film," *J. Soc. Mot. Pict. Eng.*, XXXIII (Sept., 1939), p. 315.

⁴ HOORN, F. W.: "Military Training and Historical Films," *J. Soc. Mot. Pict. Eng.*, XXI (Oct., 1933), p. 337.

⁵ GILLETTE, M. E.: "The Use of Films in the U. S. Army," *J. Soc. Mot. Pict. Eng.*, XXVI (Feb., 1936), p. 173.

⁶ PROSSER, W. E.: "Motion Picture Activities of the United States Army," *Trans. Soc. Mot. Pict. Eng.*, No. 38 (May, 1929) p. 355.

ADDITIONAL REFERENCES

Commission on Educational and Cultural Films, "The Film in National Life," *George Allen and Unwin Ltd.* (London), 1932.

DEVINE, J. E.: "Films as an Aid in Training Public Employees," Report to the Committee on Public Administration, *Social Science Research Council*.

DISCUSSION

MR. BRADY: Has industry taken to the motion picture to a large extent?

MR. HARGROVE: There are today forty-eight fairly large industrial companies who are making their own motion pictures, most of them in the 16-mm size.

MR. BRADY: What prevents industrial companies from seeing immediately the advantages of the 16-mm film?

MR. HARGROVE: Probably the lack of understanding of what can be done with the medium, and the general idea that a motion picture has to be entertaining, rather than educational or instructional.

MR. BRADY: Is the cost or the lack of projection equipment an important factor?

MR. OFFENHAUSER: Not as much as a better understanding of the principles involved. The films mentioned in the Harvard announcement, for example, are films that could be made with the cheapest of 16-mm cameras.

MR. MITCHELL: Quite a number of industrial concerns have started to use 16-mm motion pictures because someone in the company had produced or designed something new, and wanted a record of what he had done. The first thing he knew, the sales department borrowed the film, and it began to attract the interest of others in the company. Many executives of the big companies do not know or appreciate how this new tool can be used.

MR. GILLETTE: One of the principal hurdles that this type of film will have to get over is to develop a new technic for presentation, differing materially from the technic of entertainment films or the pure advertising film. The technic of making successful instructional films differs greatly from that of making the entertainment variety.

If instructional films are to be effective they must go further into details, avoid distractions such as extraneous material, comedy, emotional appeals, and unrelated scenes, and conform to the basic principles covering the preparation of instructional material. Also the methods of using such films should conform to educational practice.

A REEL AND TRAY DEVELOPING MACHINE*

ROY S. LEONARD**

Summary.—A 200-foot reel and tray developing machine with multiple trays, motor driven reels, and manual reel transfer, is described. Fresh processing solution is used with every reel, the amount depending upon the footage of the reel.

Difficulties encountered in development and construction are described, and the advantages evident in practice are given as one-man operation; solution economy; clean, energetic development, with linear exposure-density relation; uniformity of results with any quantity of film from 1 to 200 feet; no undue aerial or chemical fog; cleanliness; and flexibility in use or in extension to future developments.

Intelligence of the highest degree, accumulated experience, and no inconsiderable amount of money have produced the remarkable equipment necessary for the accurate processing of motion picture film in great quantities, but little attention has been given to the needs of the many small laboratories scattered throughout the United States and other countries. The total footage processed by these small laboratories must be considerable, but their work rarely warrants the cost of even the smallest of continuous machines, or of maintaining the required large quantities of solution.

Mechanical deficiencies and the impossibility of obtaining uniform agitation make the pan and spiral reel type of equipment impracticable. Variations of the spiral reel system have been devised, but they require large quantities of solution.¹ The rack and tank system still survives—with all its inherent faults of air bells, rack marks, differential development with increasing depth of solution, impossibility of proper agitation, polluted and leaking tanks, *etc.*^{2,3,18} Most important, the amount of developer can not be reduced to just enough for a rack of film, so compensation for developer depletion must be made, a difficult problem even in a well equipped laboratory. Motor-driven racks of the looped film type have been devised, but again large quantities of solution are required.⁴

To overcome such handicaps, the following design requirements

* Presented at the 1939 Spring Meeting at Hollywood, Calif.; received February 6, 1939.

** Municipal Light and Power System, Seattle, Wash.

were indicated: speed, with ease and certainty of operation; no possibility of film distortion or damage; uniform and adequate agitation; the use of new solution for every charge of film processed, with solution quantity entirely according to the amount of film in each charge so that the depletion rate would be identical with any amount of film; and a capacity of 1 foot to 200 feet per charge. Certainly it is undesirable to cut a 1000-foot roll, but flexibility and size limitations make greater capacity impracticable.

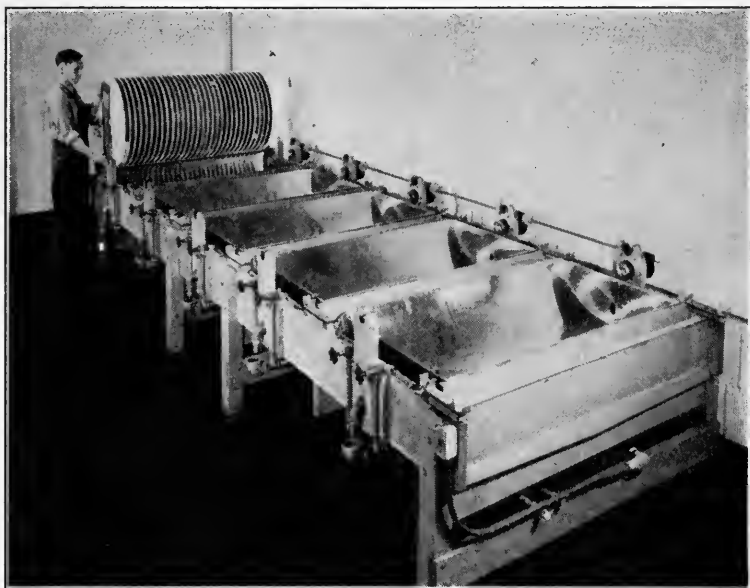

FIG. 1. The complete developing machine.

A reel and tray machine meeting these design considerations has been built, and has given consistent and economical results. Fig. 1 shows the complete machine, but not the standard type drying reel on which the film is rewound. There are five solution trays, all over a main tray draining to the sewer. Each tray has a hot and a controlled temperature water supply, and an independent drain to save solutions or to discard to the sewer. Each tray has bearing pedestals and a driving gear to engage the drum gear as it is dropped into place.

Fig. 2 shows the manual transfer of a drum from tray to tray by means of the lever mechanism carried along with the drum. Drums are moved from rear to front of the machine on a wheeled carriage. Fig. 3 shows the carriage in position for transfer of the drum to the machine.

A rectangular spiral wire soldered to the drum face guides the film so that winding is easily done in the dark. Very short lengths of film may be attached with adhesive tape, but it is necessary that

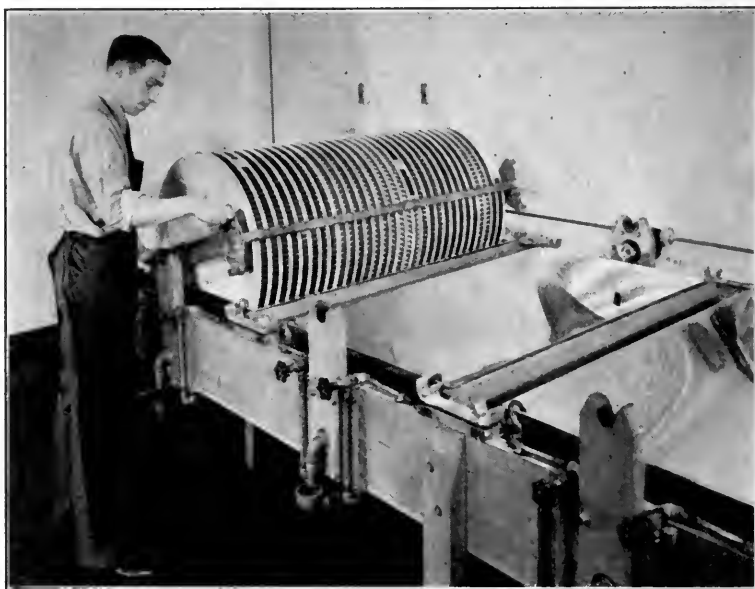

FIG. 2. Showing the manual transfer of a drum from tray to tray by means of the lever mechanism on the drum.

the film be kept tight on the drum, and the longer lengths are fastened with clips and rubber bands to take up the expansion.

As expected in any development, difficulties were encountered in the construction of this machine. The reel and tray system^{5,18,19} gave promise of solution economy and uniform agitation, but several inherent faults had to be overcome. Trials with a wooden cage type of reel proved aerial fog to be at a minimum with fresh developer of either the borax or the positive type. A low-fog developer recommended for reel use,^{3,16,18} and pinacryptol green^{6,16} both increased

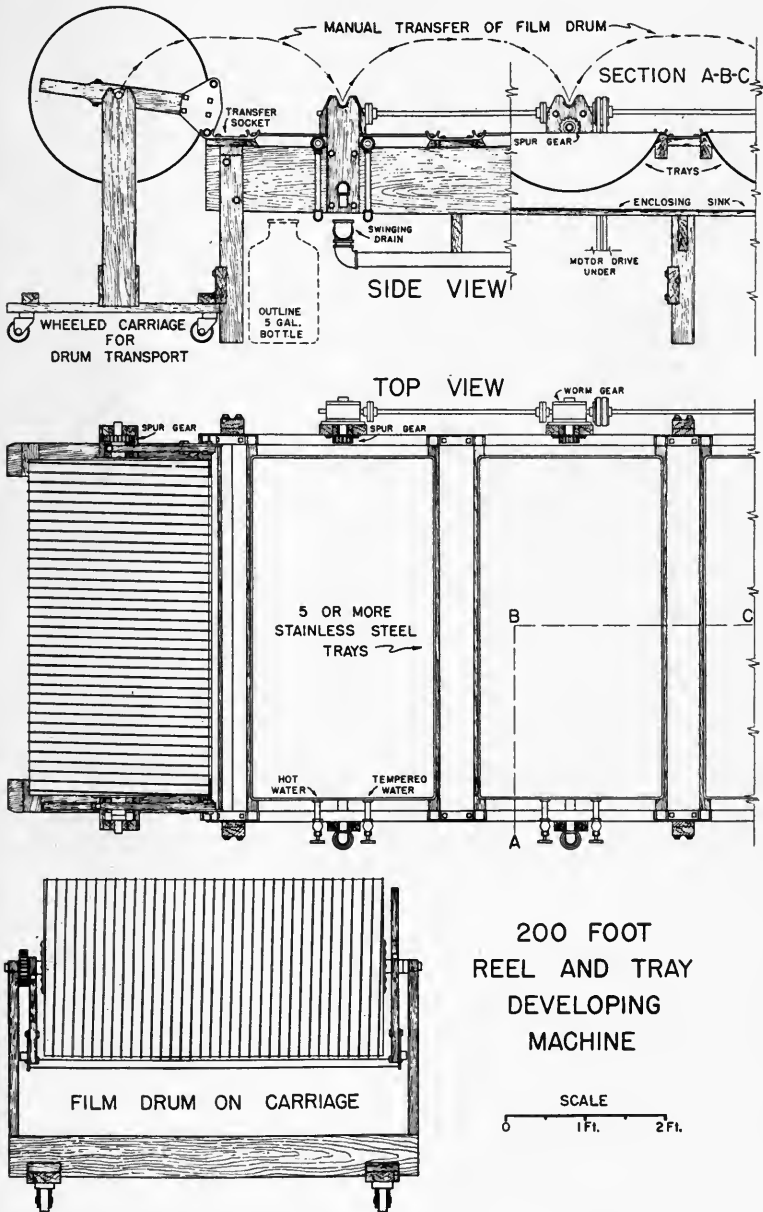

FIG. 3. Two-hundred ft reel and tray developing machine.

rather than reduced fog. No attempt is made to explain this absence of aerial fog unless the use of fresh solution is responsible.

The paddle-wheel effect of the trial wooden cage drum caused uneven development. To eliminate this, and for solution economy, a closed type of drum was indicated.

It was believed necessary that wash water reach the rear surface of the film, so a trial section of a fluted drum was built. This seemed satisfactory, but a full sized drum gave uneven development because of developer surging through the film perforations into and out of the fluting.⁷

Tests with a flat drum face showed that uniformity could be realized if the film remained flat on the surface so that developer could not circulate through the perforations.

A smooth drum with a spiral film guide proved satisfactory, but expansion of the wet film, which was found to exceed 3 feet in a 200-foot length of acetate base, although much less with nitrate, caused overlapping of the center turns. Rubber bands took up the expansion at the ends but not at the center. A specially made soft-bristle brush held in contact with the revolving drum helped to carry the film expansion to one end of the drum where it could be taken up by the rubber band, but this could at best be only a temporary expedient.

At a trial peripheral speed of 90 feet per minute, it was found that sufficient developer was not carried over with the drum and development streaks resulted.

The drum speed was increased to 250 feet per minute, almost to the splash point. At this speed an appreciable quantity of developer carried around the drum, and uniform development was achieved. At this speed also, the film expansion carried to the drum end, and the overlapping of turns was eliminated.

It was expected that this high film speed would cause directional degradation,⁸ but examination, under a microscope, of heavily exposed areas adjacent to clear film showed no apparent trace of directional effect. Had this effect been evident, it was anticipated that periodic reversal of the drum would reduce or partially equalize the image spread.

Development tests with film strips exposed to a point light-source showed satisfactory uniformity of density, and no difference in development was evident at the center or at either end of the drum.

It was expected that contact of the film base with the smooth drum would prevent removal by the wash water of traces of processing

solutions. Examination of film dried on the drum showed no great amount of solids and it was planned to remove these traces in a supplementary bath combined with a squeegee.

Clearance between drum and tray had been kept to a minimum, and it was found that one gallon of solution was just as effective in wetting the film as a great quantity.

The high drum speed caused extremely energetic development, and it was found necessary to reduce the development rate. Dilution provided insufficient reduction, and dilution caused some developer constituents such as elon to be reduced to unreasonable amounts. Buffering the negative developer with boric acid in the proportion of 3 to 1 and reducing the alkalinity of the positive developer proved satisfactory.^{9,16} Sodium carbonate in reduced quantities does not follow a linear alkalinity rate, so Kodalk was substituted.¹⁶ A satisfactory development rate was obtained, but it was found that a developer compounded with Kodalk was sensitive to the aeration caused by the reel, and the development rate rapidly decreased independently of depletion.

Tests were made of depletion rates and a decided difference in density was found between the development of short lengths and the full 200-foot length. It had been anticipated that the spiral on the drum would cause adequate developer circulation, but tests with a dye solution placed in one end of the tray showed little circulation tendency. Two solutions to the problem were evident, developer circulation with a pump, or fractional footage reels. The latter was chosen and a 100-foot, a 25-foot, and a one-turn drum built. Other drums could have been made, but a reasonable balance had to be arrived at between cost and developer economy. The 100-foot size is useful for spring-wound camera rolls and for 16-mm if desired; the 25-foot for shorter lengths and for printer-light tests; and the one-turn or 7-foot drum for sensitometric strips, exposure tests, or miniature camera rolls. Fig. 4 shows these drums mounted on a single shaft. A removable tray, divided into compartments to fit these individual drums, permits use of the proper amount of developer.

Tests of depletion rates showed 100 feet per gallon to be a satisfactory compromise. This could be greatly exceeded in controlled practice with diluted solutions. The use of fresh solution seems to extend greatly the possible footage per gallon.

The compromise between fractional size drums, and the rate of 100 feet per gallon, has produced in practice no discernible differ-

ence in density or contrast in development between 7 feet or intermediate lengths to 200 feet.

The first two of the present five trays can be used for developer and short stop, or for two-solution development,^{10,16} the last two for increased washing capacity. The high drum speed with the small amount of wash water in the tray and its rapid rate of change, permit a high rate of hypo diffusion from the film with consequently shorter washing time.^{11,17}



FIG. 4. The 100-ft, 25-ft, and 7-ft drums mounted on a single shaft.

Additional trays could be easily added if necessary for special work. The use of multiple trays makes possible uranium or other toning methods¹² and permits future processing of colorfilm if several solutions are necessary for the colorfilm of the future. Special treatment, such as intensification or reduction is also easily accomplished.^{13,20}

The use of smooth-surface white drums and a tubular or uniform light-source over the drum, also makes possible overall reversal of film.

The advantages evident in practice are summarized: one-man operation; ease of film loading and reel transport; cleanliness; solution

economy; low film tension, with no stretching or damage; uniformity of results independently of the footage; no undue aerial or chemical fog caused by partially exhausted or polluted solutions; clean, energetic development with straight H&D curves; and flexibility in use or extension to future developments.

The disadvantages evident are space requirements; drums somewhat heavy and of a rather high cost; the need of cutting film greater in length than 200 feet; and incomplete removal of solution traces from the film base without a supplementary bath.

The 100-foot drum might be eliminated by circulating the developer, but the one-turn and the 25-foot drum are both desirable and necessary.

Drums are made of iron with the spiral soldered in place. It was found that cold wash water caused condensation and corrosion of the drum interior and it was necessary to protect all inside drum surfaces thoroughly. The cost might be reduced with wood construction and monel staples for film-guides, but special precautions would have to be taken to insure a water-tight drum. Trays are made of stainless steel^{14,15,19} but could be made of iron and coated with flexible air vulcanizing rubber enamel. Because of the great amount of soldering,^{15,19} stainless steel was not considered practicable for the drums, so a hard rubber enamel is used which has proved highly resistant to solutions, but somewhat susceptible to chipping.

Acknowledgment is made of the invaluable assistance rendered by Emery Huse of the Eastman Kodak Company and to W. J. Ellis, W. G. Elder, and L. C. Danby of the Department staff.

REFERENCES

¹ "The Davidge Developing Apparatus," *J. Soc. Mot. Pict. Eng.*, **XXIV** (May, 1935), p. 452.

² CRABTREE, J. I., AND IVES, C. E.: "Rack Marks and Airbell Markings on Motion Picture Film," *Trans. Soc. Mot. Pict. Eng.*, No. 24 (Oct., 1925), p. 95.

CRABTREE, J. I.: "Uniformity in Photographic Development," *J. Soc. Mot. Pict. Eng.*, **XXV** (Dec., 1935), p. 512.

DUNDON, M. L., AND CRABTREE, J. I.: "Investigations on Photographic Developers—Sulfite Fog by Bacteria in Motion Picture Developers," *Trans. Soc. Mot. Pict. Eng.*, No. 19 (Sept., 1924), p. 28.

³ DUNDON, M. L., AND CRABTREE, J. I.: "The Fogging Properties of Developers," *Trans. Soc. Mot. Pict. Eng.*, **XII**, No. 36 (1928), p. 1096.

⁴ IVES, C. E.; "A Roller Developing Rack for Continuously Moving the Film during Processing by the Rack-and-Tank System," *J. Soc. Mot. Pict. Eng.*, **XXIV** (Mar., 1935), p. 261.

IVES, C. E.: "An Improved Roller Type Developing Rack with Stationary Drive," *J. Soc. Mot. Pict., Eng.*, **XXXI** (Oct., 1938), p. 393.

⁵ CRABTREE, J. I.: "The Development of Motion Picture Films by the Reel-and-Tank Systems," *Trans. Soc. Mot. Pict. Eng.*, No. 16 (May, 1923), p. 163.

⁶ DUNDON, M. L., AND CRABTREE, J. I.: "The Effect of Desensitizers in Development," *Trans. Soc. Mot. Pict. Eng.*, No. 26 (1926), p. 111.

⁷ FRAYNE, J. G., AND PAGLIARULO, V.: "The Influence of Sprocket Holes upon the Development of Adjacent Sound-Track Areas," *J. Soc. Mot. Pict. Eng.* **XXVIII** (Mar., 1937), p. 235.

⁸ CRABTREE, J. I.: "Directional Effects in Continuous Film Processing," *J. Soc. Mot. Pict. Eng.*, **XVIII** (Feb., 1932), p. 207.

CRABTREE, J. I., AND WADDELL, J. H.: "Directional Effects in Sound Film Processing—II," *J. Soc. Mot. Pict. Eng.*, **XXI** (Nov., 1933), p. 351.

⁹ MOYSE, H. W., AND WHITE, D. R.: "Borax Developer Characteristics," *J. Soc. Mot. Pict. Eng.*, No. 38 (May, 1929), p. 445.

CARLTON, H. C., AND CRABTREE, J. I.: "Some Properties of Fine-Grain Developers for Motion Picture Film," *Trans. Soc. Mot. Pict. Eng.*, **XIII**, No. 38, (1929), p. 406.

CRABTREE, J. I., AND IVES, C. E.: "A Replenishing Solution for a Motion Picture Positive Film Developer," *J. Soc. Mot. Pict. Eng.*, **XV** (Dec., 1930) p. 627.

¹⁰ CRABTREE, J. I., PARKER, H., JR., AND RUSSELL, H. D.: "Some Properties of Two-Bath Developers for Motion Picture Film," *J. Soc. Mot. Pict. Eng.*, **XXI** (July 1933), p. 21.

¹¹ RUSSELL, H. D., AND CRABTREE, J. I.: "An Improved Potassium Alum Fixing Bath Containing Boric Acid," *J. Soc. Mot. Pict. Eng.*, **XXI** (Aug., 1933), p. 139.

¹² CRABTREE, J. I., AND IVES, C. E.: "Dye Toning with Single Solutions," *Trans. Soc. Mot. Pict. Eng.*, No. 36 (Sept., 1928), p. 967.

CRABTREE, J. I., AND MARSH, W.: "Double Toning of Motion Picture Films," *J. Soc. Mot. Pict. Eng.*, **XVI** (Jan. 1931), p. 57.

Eastman Kodak Co., "Tinting and Toning of Eastman Positive Motion Picture Film."

¹³ CRABTREE, J. I., AND MUEHLER L. E.: "Reducing and Intensifying Solutions for Motion Picture Film," *J. Soc. Mot. Pict. Eng.*, **XVII** (Dec., 1931), p. 1001

¹⁴ MITCHELL, W. M.: "Applications of Stainless Steels to the Motion Picture Industry," *J. Soc. Mot. Pict. Eng.*, **XXIV** (April, 1935), p. 346.

LAQUE, F. L.: "Iconel as a Material for Photographic Film Processing Apparatus," *J. Soc. Mot. Pict. Eng.*, **XXIV** (April 1935) p. 357.

LAQUE, F. L., "Some General Characteristics of Chromium Nickel-Iron Alloys as Corrosion-Resisting Materials," *J. Soc. Mot. Pict. Eng.*, **XXXII** (May, 1939), p. 505.

¹⁵ CRABTREE, J. I., MATTHEWS, G. E., AND ROSS, J. F.: "Materials for the Construction of Motion Picture Processing Apparatus," *J. Soc. Mot. Pict. Eng.*, **XVI** (March, 1931) p. 330.

¹⁶ Eastman Kodak Co., "Motion Picture Laboratory Practice." Chap. IV, Developers and Development.

¹⁷ *Ibid.* Chap. V, Fixing, Washing, and Drying.

¹⁸ *Ibid.* Chap. VI, Processing Motion Picture Film.

¹⁹ *Ibid.* Chap. VII, Processing Difficulties.

²⁰ *Ibid.* Chap. XII, Intensification and Reduction.

CONSIDERATIONS RELATING TO WARBLER FREQUENCY FILMS *

E. S. SEELEY**

Summary.—Some warbled frequency films, intended as signal sources for acoustical response measurements, appear to have been made and used without full realization of the true nature of the warbled signal and the manner in which such a signal is affected by a non-linear transmission system. It is pointed out that the warbled signal is a frequency-modulated signal; hence the signal may be represented by a carrier frequency and a series of side-frequencies, all of which are steady and discrete. It is pointed out, and substantiated experimentally, that the signal must be regarded in this light when considering the effect on it of a non-linear transmission system. The frequency structure of one "warble film" in use is calculated and shown graphically. Fundamental requirements for a suitable warbled frequency film having sinusoidal modulation are discussed and values for modulation rate and for modulation depth are recommended. The side-frequency array provided by the recommended modulation constants is shown in graph form. Expressions are derived giving the frequency relationship and relative amplitudes of the side-frequencies resulting from the non-sinusoidal frequency modulation which contains two components of modulation rate, one component having an associated phase constant. The side-frequency structures corresponding to some assumed combinations of two rates are calculated and illustrated. Certain assumptions are made for distortion or departure from sinusoid of a modulating frequency and the effects on the side-frequency structure are shown. From the latter calculation recommendations are derived for tolerances of departure from sinusoidal modulation for a warbled frequency film.

It is well known that the use of steady sinusoidal signals for response measurements on a loud speaker system in an auditorium results in a highly irregular response curve; that is, the acoustic response varies widely between two frequencies closely spaced. Fig. 1 illustrates a portion of such a frequency response measurement made using steady sinusoidal signals, the microphone being placed near the center of a small live room. The data are plotted to an expanded frequency scale. It will be observed that the characteristic consists of a succession of peaks and valleys joined by abrupt slopes.

* Presented at the 1939 Fall Meeting at New York, N. Y.; received October 7, 1939.

** Altec Service Corp., New York, N. Y.

To point out an extreme, a change in response of as much as 24 db in a frequency shift of 1 cps or 1 per cent was recorded.

The irregularities revealed by such measurements are usually ascribed to cancellation and reinforcement resulting from phase differences between direct and reflected waves reaching the microphone simultaneously. Although various substitutes for steady sinusoidal signals have been proposed, the substitute in widest use is the "warble tone." A warbled signal is often thought of by users of warbled frequency films as a signal of only one frequency, and therefore sinusoidal, but of a frequency which varies in value back and forth over a limited range. Its action is accordingly regarded

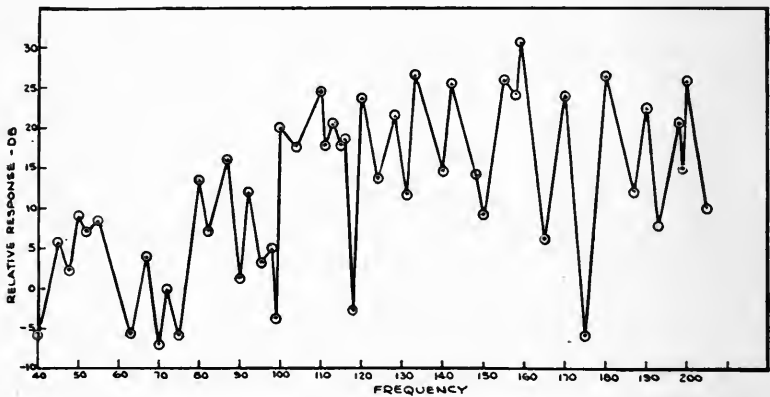

FIG. 1. Acoustical response measured in a small room, using sinusoidal signal.

as preventing the establishment of standing waves by virtue of eliminating the coincidence of a direct and a reflected wave of the same frequency, and as providing an average response over the frequency interval of the modulation by integrating the response to an infinite number of instantaneous frequencies over the interval. This concept of the warbled signal will be referred to in the following discussion as the "swinging-frequency" viewpoint.

The warbled signal is an instance of frequency modulation. The instantaneous value of the pressure or velocity of the acoustic waves produced by sinusoidal frequency modulation are proportional to

$$\begin{aligned}
 q &= \sin(\omega t + k \sin \mu t) \\
 \text{where } \frac{\omega}{2\pi} &= f_0 \text{ the mean frequency,} \\
 k &= \frac{m\omega}{\mu} \\
 m &= \text{per cent modulation expressed as a fraction,} \\
 \frac{\mu}{2\pi} &= p, \text{ the modulation rate}
 \end{aligned}
 \tag{1}$$

Several writers^{1,2,3} have shown that eq. 1 may be expressed in the form

$$\begin{aligned}
 q &= J_0(k) \sin \omega t + J_1(k)[\sin(\omega + \mu)t - \sin(\omega - \mu)t] \\
 &\quad + J_2(k)[\sin(\omega + 2\mu)t + \sin(\omega - 2\mu)t] \\
 &\quad + J_3(k)[\sin(\omega + 3\mu)t - \sin(\omega - 3\mu)t] \\
 &\quad + \text{etc.}
 \end{aligned}
 \tag{2}$$

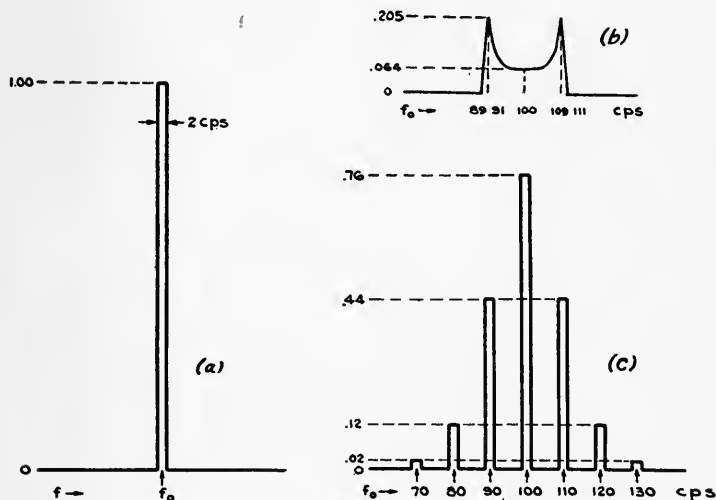

FIG. 2. Predicted transmission of warble signal: 100 cps modulated $\pm 10\%$ ten times per second. Transmission system assumed to have characteristic *a*. The output signal amplitude will vary with location of f_0 . (b) Output variation as predicted by "swinging-frequency" analysis; (c) output variation predicted by "side-frequency" analysis.

The coefficients $J_n(k)$ are Bessel functions of the n th order and of argument k .

Here we find that the warble tone is made up of a number of components, each sinusoidal, having frequencies $f_0 + p$, $f_0 - p$, $f_0 + 2p$, $f_0 - 2p$, etc. This concept of the warbled signal will be referred to in the ensuing discussion as the "side-frequency" viewpoint.

It is a common error to assume that the two viewpoints are merely two ways of saying the same thing and that both lead to the same conclusions. On the contrary, the two viewpoints might lead to very different predictions of the effect on the signal of a transmission system possessing frequency discrimination. This point is well illustrated by considering a transmission system having a transmission band only a few cycles in width. Such approximately is the characteristic of a wave analyzer. Assume a signal having a mean frequency of 100 cps sinusoidally modulated ± 10 per cent, that is, from 90 to 110 cps, at a rate of 10 times per second. Assume also, to simplify the problem, that the pass-band is two cycles in width as shown in Fig. 2(a) and that frequencies outside the pass-band are infinitely attenuated. The "swinging-frequency" viewpoint would lead to the prediction illustrated in Fig. 2(b) that with the pass-band centered at 100 cps the indication would be 6.4 per cent of the steady 100-cycles reading; that is, the instantaneous frequency would be expected to be between 99 and 101 for 6.4 per cent of the time. When the pass-band is centered slightly to either side of 100 cycles the reading would increase to a maximum of 20.5 per cent when centered at 91 or 109 cps; after which it would fall off to zero below 89 cps and above 111 cps.

The "side-frequency" mode of analysis leads to quite different predictions. The assumed warble signal is found by eq. 2 to be made up of components having frequencies and amplitudes as follows:

Frequency	Amplitude Relative to Unmodulated Signal
100 cps	0.76
90 and 110	0.44
80 and 120	0.12
70 and 130	0.02
Below 70 and above 130	Negligible

These figures show that the energy is not spread continuously over the frequency range 90 to 110 cps, but that it is lumped at discrete frequencies spaced 10 cps apart and that an appreciable part of it is found as low as 80 and as high as 120 cps. The prediction one must make of the manner in which this composite signal would be transmitted over our hypothetical system is indicated in Fig. 2(c).

Predictions (b) and (c) in Fig. 2 are so different as to be irreconcilable and it should not be difficult to establish clearly which is correct. Accordingly the described warble tone was applied to a wave analyzer having a transmission characteristic approximating that illustrated

in Fig. 2(a) sufficiently to serve our purpose. The largest reading was obtained at 100 cps; no energy was found between the side frequencies; the readings at 80 and 120 cps were easily obtained, and energy indications were obtained at 70 and 130 cps.

The conclusion is that the side-frequency viewpoint must be employed or serious misconceptions may result. To go further, it seems safe to say that the frequency-modulated signal, despite the mechanism by which it is produced, is not a sine wave the frequency of which is continuously varying, but a series of sinusoidal waves of definite frequencies separated numerically by the modulation rate. In this connection, the mathematician might say that a sinusoidal wave of varying period is not a sinusoidal wave at all, and therefore that the "swinging-frequency" concept is based upon a contradiction of terms.

The merit of the warbled signal for acoustical measurements resides in its multiple-frequency character. However, the side-frequency analysis warns us that the number of frequencies of significant amplitude may be quite small and the separation frequency quite large. Each of the components, it will be observed, is itself a steady sinusoidal signal and therefore capable of setting up standing waves and susceptible to interference. Appraised in the light of its side-frequency composition, a warbled signal might be found inadequate even though it may have been judged quite satisfactory from the "swinging-frequency" viewpoint. An example is a warble film in fairly common use, the modulation of which is given as ± 5 per cent and the rate about 8 per second. The frequency composition of the signals produced by such modulation is shown for the lower frequencies in Fig. 3. This illustration leads to the conclusions that the patterns for mean frequencies of 300 cps and above are satisfactory since they contain a considerable number of components in a reasonably compact arrangement, but that at the lower mean frequencies an insufficient number of components exists and the carrier contains too large a percentage of the total energy; thus tending too much toward the pure sinusoidal signal.

The following generalization will be found useful in planning a more suitable type of modulation:

Approximately 96 per cent of the energy in the composite signal is contained in components having frequencies equal to the mean frequency and all side frequencies up to and including the $\pm n$ th side frequency, where n is equal to the modulation index k in eq. 1.

(3)

From the foregoing rule, which can be verified numerically from a table of Bessel functions, and the fact that the separation of the side frequencies is equal to the modulation rate p , several relationships may be deduced. The "effective band-width," that is, the width of the frequency range in which is included approximately 96 per cent of the total energy, is equal to the side-frequency separation times the number of separations:

$$e.b.w. = 2pn = \frac{2pmf_0}{p} = 2mf_0 = 2\Delta f \quad (4)$$

where m is per cent modulation, expressed as a fraction

f_0 is the mean frequency

Δf is the apparent extreme instantaneous deviation from the mean frequency.

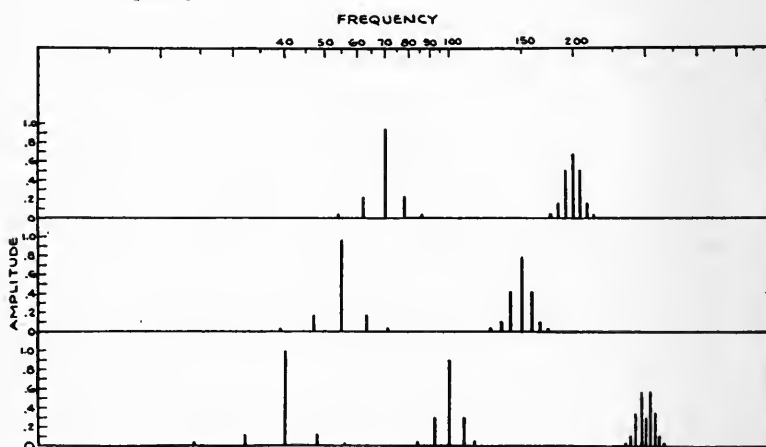

FIG. 3. Spectral distribution of warble signals: modulation $\approx 5\%$; rate 8 cps; modulation sinusoidal.

Hence the effective band-width is independent of p .

Note.—It is interesting to observe that the "effective band-width" is equal to that which would be expected from the "swinging-frequency" mode of analysis. In this particular respect the two viewpoints lead to the same conclusion.

The number of components included in the "effective band-width" is

$$2n + 1 = \frac{2mf_0}{p} + 1 = \frac{e.b.w.}{p} + 1 \quad (5)$$

It is apparent from these relations that, to obtain a large number of frequencies within the band at low mean frequencies, it is necessary

to employ a large value for m/p , or, for a given band-width, p must be small. Since it is desirable to obtain in the effective band as large a number of components of different frequency as practicable, reduction of p to very small values would be indicated.

Reduction of warble rate, however, introduces an opposing consideration in the form of amplitude modulation. The superposition of a number of sinusoidal signals differing slightly in frequency would rightly be expected to result generally in amplitude variation at low rates, the rates being related to the difference in frequencies. The relation between amplitudes and phases of the signals set up by frequency modulation represents a special case of multiple-frequency superposition and for this case the composite wave amplitude is constant. Any disturbance of this relationship, however, whether it be due to frequency-selective action of the direct transmission system or due to a selective action of reflecting surfaces or space on the reflected waves, introduces an amplitude variation, the lowest frequency of which is numerically the frequency separation of the signals; that is, the frequency-modulation rate. If the rate is made very low, the needle of the level indicator will tend to follow the amplitude variations. There is a distinct disadvantage in indicator needle unsteadiness in that greater care is required to determine the average reading. The avoidance of serious needle unsteadiness leads to the lower limit of modulation rate. The *TA-4145* output meter probably is used more widely in theaters, in this country and elsewhere, than is any other type of level indicator. The ballistic properties of this meter are such that when a pulsating (square wave) d-c signal varying from zero to three volts 2.5 times per second is applied, the needle oscillates ± 1.3 db on the 6-volt scale. Hence if serious unsteadiness is to be avoided when using this meter, the warble rate should not be less than 2.5 cps.

Using a warble rate of 2.5 cps and selecting 5 as the minimum number of frequencies in the effective band centered about 40 cps leads to a figure for m of 12.5 per cent. While a larger number of frequencies would be preferable, they could be obtained only by further reduction of the warble rate or increase in m above 12.5 per cent, both of which appear undesirable. Fig. 4 illustrates the frequency composition of signals modulated in accordance with these constants for several low mean frequencies. It appears undesirable to increase the modulation above 12.5 per cent due to the overlapping of the band-widths about adjacent mean frequencies.

Fig. 5 presents an appraisal of the adequacy of these suggested warble signals. The response characteristic shown in Fig. 1 is used for the purpose. Based on the response as drawn, calculations were made of the response to warble signals having a composition like that of the proposed 40-cycle warble signal but located at various frequencies below 100 cycles. Above 100 cycles the calculations were made for a warble signal having a composition like that of the proposed 100-cycle warble tone. The band-width of the 40-cycle signal being 10 cycles and that of the 100-cycle warble tone being 25 cycles, the *true mean* response of the system was calculated for these band-widths centered at the same mean frequencies as used in the

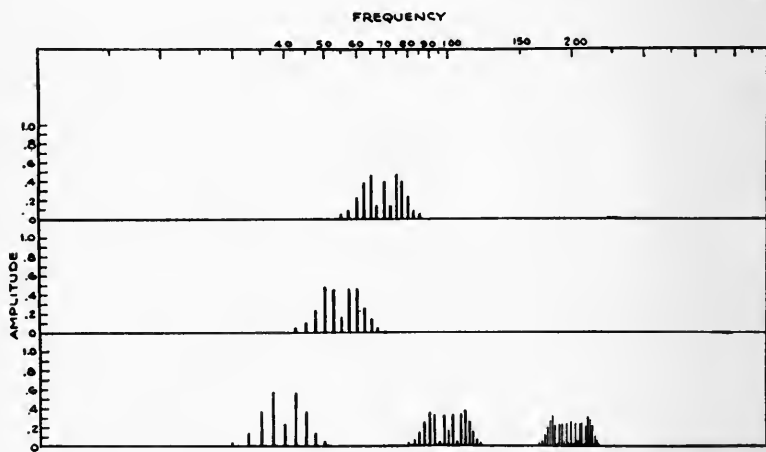

FIG. 4. Spectral distribution of warble signals: modulation $\approx 12.5\%$; rate 2.5 cps; modulation sinusoidal.

previous calculation. The results of the latter calculation are plotted as circles. For the 15 points computed below 100 cycles the average departure from the mean (averaged without regard to the sign) was 0.69 db and the maximum departure from the mean was -1.8 db. The improved composition of the signal used above 100 cycles resulted in an average departure from the mean of 0.58 db and the maximum departure of -1.3 for the 9 points computed. A further calculation was made to include in the same comparison the results that would be obtained using a signal proposed by Barrow,⁴ which he calls the "multi-tone." This signal as illustrated consists of components of equal amplitude distributed uniformly over the band-width. Since

such a signal is also subject to the limitation which controls the lower limit of modulation rate for the warble tone, it is necessary to assume the same number of components in the multi-tone as are obtained in the warble tone. The composite multi-tone and warble tone signals are given equal amplitude if the individual components of the multi-tone are made equal to one over the square-root of the number of

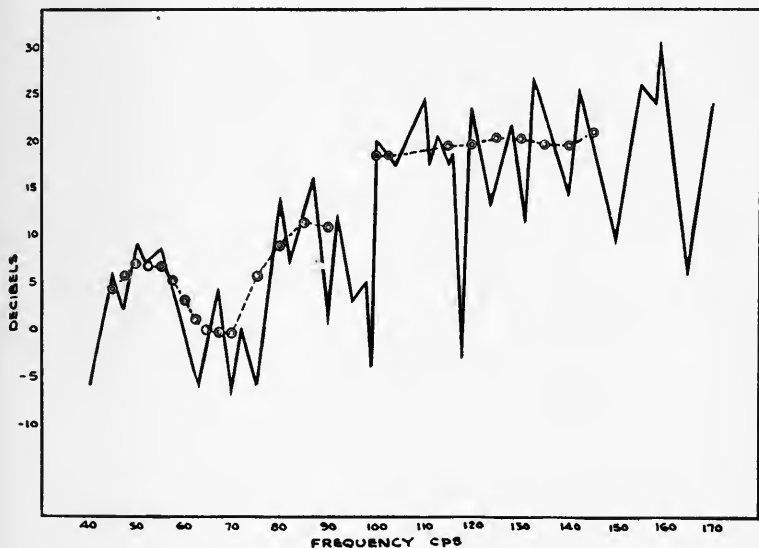

FIG. 5. Calculated response using complex signal. Solid lines join points measured using sinusoidal signal; circle points: "mean" calculated for bands 10 cps wide below 100 cps and 25 cps wide above 100 cps.

	Below 100 cps		Above 100 cps	
	Multi-tone	Warble-tone	Multi-tone	Warble-tone
Average dep. from "mean"	0.55 db	0.69 db	0.54 db	0.58 db
Max. dep. from "mean"	-2.0 db	-1.8 db	-1.1 db	-1.3 db

components. Such a signal might be expected to yield results somewhat more accurate than those given by the warble tone. As shown in Fig. 5, this was found to be the case, but the difference as revealed by this series of computations is so small that the two would be considered to yield practically equal accuracy when used for measurement of acoustic response.

It has also been pointed out⁵ by Barrow that a warble tone, to neutralize effectively the standing waves resulting from a single reflecting surface, must have a spectral distribution which embraces half a wavelength of the standing wave; that is, from a node to an antinode. At 40 cps, a modulation of ± 12.5 per cent produces a band-width of 10 cps, which will embrace node to antinode if the path difference is 54 feet or more. If the reflecting surface under consideration is normal to the path of incident sound to the microphone, the surface must be 27 feet from the microphone. If the surface is half this distance away only half the node-to-antinodal wavelength will be under measurement, with the result that variations theoretically as great as 8 db could be obtained by moving the microphone to various phase locations in the standing wave if a single reflected wave is considered and the surface is assumed to be without absorption.

No way out of this dilemma can be suggested if it is desired to make measurements near the walls of an auditorium. To increase the modulation sufficiently to bridge the gap would mean that the entire low end of the spectrum would be plotted at a single point. However, the picture is not as dark as might be expected since reflected waves reach the microphone from a large number of surfaces, none of which is without absorption; and the practice of making measurements at a number of points in an auditorium without attaching too much significance to the readings at any one point also tends to mitigate the shortcomings of a reasonable modulation.

The disagreement of this conclusion with the requirement postulated by Barrow, *viz.*, that the band-width should extend from node to antinode, results from the differing applications considered for the warble tone. Barrow's analysis applies to the use of the warble tone for reverberation measurements where presumably the interest is centered in sound-absorbing materials, whereas the present discussion is restricted to the warble tone in response measurements wherein the auditorium with its variable local characteristics are the significant factors.

The foregoing discussion is based on sinusoidal modulation. An analysis was made to reveal the effect of departures from true sinusoidal modulation. Formulas giving the side-frequency amplitudes were derived for modulation at two simultaneous rates with a phase-constant defining their phase relationship. These expressions are derived in an Appendix. Three particular cases are illustrated in Fig. 6 for mean frequencies of 40 and 100 cps: a 25-per cent second

harmonic of the modulating rate with no phase constant, a 25-per cent second harmonic having a 90-degree displacement from the fundamental, and a 50-per cent second harmonic displaced 90 degrees.

It is interesting to note that distortion in the modulation-time law of the kind which makes the half-cycles asymmetrical about the mid-

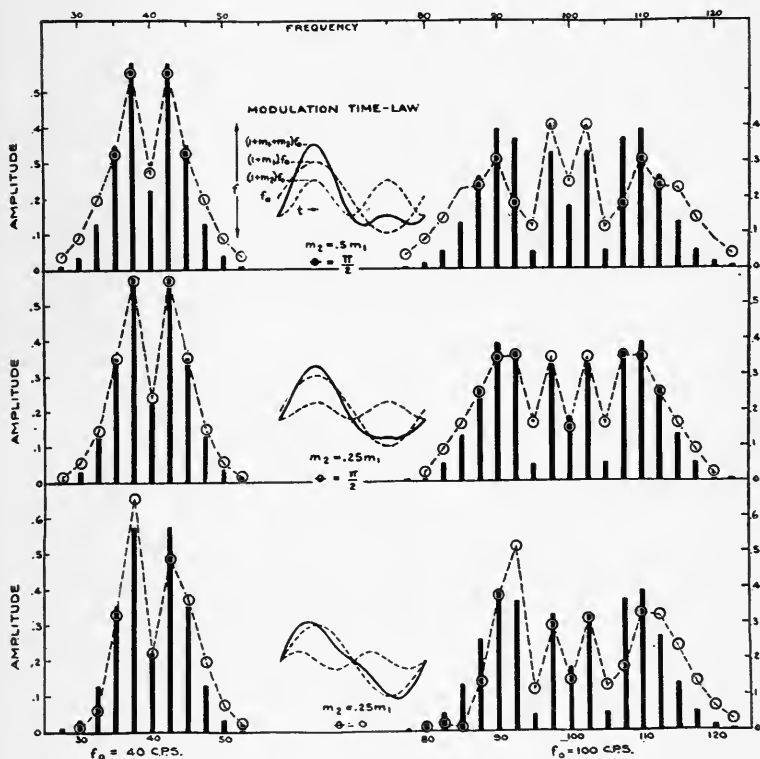

FIG. 6. Effect of departures from sinusoidal modulation. Vertical bars represent spectral distribution of sinusoidal modulation of $\approx 12.5\%$ at 2.5 cps. Circles represent spectral distribution for modulation illustrated and defined by

$$f = f_0[1 + m_1 \sin 2\pi p_1 t + m_2 \sin (2\pi p_2 t + \theta)]$$

For all cases illustrated $m_1 = 0.125$; $p_1 = 2.5$ cps; $p_2 = 5$ cps.

points produces asymmetry of the side-frequency array. Conversely, distortion which leaves the half-cycles symmetrical about their mid-points does not disturb the symmetry of the side-frequency amplitudes about the mean frequency but does alter the amplitudes. Al-

though not shown, third-harmonic distortion produces qualitatively similar results.

In the asymmetrical cases it will be observed that the non-sinusoidal modulation contains a single component that may tend to dominate the composite signal and for that reason it would appear desirable to limit the second harmonic to 10 or 15 per cent of the fundamental for the condition of zero phase-angle. In the symmetrical cases it is found that a 25-per cent second harmonic gives rise to a spectral distribution which is no less satisfactory than that corresponding to sinusoidal modulation. A 50-per cent second harmonic with zero phase-angle may, however, produce undesirable accentuation of a small number of the components, and also increases the amplitude of the more remote side frequencies.

Appropriate restraint forbids the drawing of broader generalizations from study of the few particular cases discussed. The method of analysis afforded by equations 13, 13(a), and 13(b) of the Appendix is submitted as providing a rigorous evaluation of the spectral distribution when the frequency-modulation time-law is completely expressed by two rates and a phase constant, or a practicable approximation when one harmonic of the fundamental warble rate predominates.

Conclusions.—No implication is intended here that the warble tone is the best type of signal for acoustical response measurements. A recent revival of interest in this field of measurement and the presence of a number of warble films in the field constitutes the reason for presenting this discussion of warble tone properties.

It is the writer's conclusion that any predictions of the effect of a warble tone are fraught with danger unless they are based on its multiple-signal aspect. This side-frequency viewpoint indicates that warbled signals for use in acoustical response measurements should have, particularly at low mean frequencies, as large a modulation as permitted by the desired separation of the mean-frequency values, and that the warble rate should be as low as allowed by the ballistics of the indicator to be used. The criterion of standing wavelength for determining modulation of a warble tone for acoustical response measurements is regarded as impracticable, due to the ambiguity of the problem when an effort is made to consider multiple reflections and multiple reflecting surfaces. Warbled signals based on a modulation of ≈ 12.5 per cent and a rate of 2.5 per second are believed satisfactory down to at least 40 cps, and the multi-tone seems to

offer little promise of significant improvement over such a signal.

In any practical case, frequency modulation will be non-sinusoidal to some degree, and the several common types of distortion of the modulating rate analyzed indicate that 10 to 15 per cent of any anticipated types of distortion and larger amounts of particular types of distortion may be tolerated without significant impairment of the signal.

APPENDIX

Analysis of Non-Sinusoidal Frequency Modulation

To limit the complexity of the final expressions, modulation at only two simultaneous rates related through a phase constant θ will be considered.

The signal is defined by

$$q = \sin [\omega t + k_1 \sin \mu_1 t + k_2 \sin (\mu_2 t + \theta)] \quad (1)$$

where μ_1 and μ_2 are the two modulation angular velocities and k_1 and k_2 the corresponding modulation indices, equal to $m_1\omega/\mu_1$ and $m_2\omega/\mu_2$, respectively, m_1 and m_2 being the modulation factors.

Expansion of the last term in the brackets of eq. 1 results in the form

$$q = \sin [\omega t + k_1 \sin \mu_1 t + (k_2 \cos \theta) \sin \mu_2 t + (k_2 \sin \theta) \sin \mu_2 t] \quad (2)$$

The parentheses are used in eq. 2 since k_2 and θ are not time variables and $(k_2 \cos \theta)$ and $(k_2 \sin \theta)$ may therefore, and will hereafter, be treated as constant factors.

From eq. 2, q is equal to the sine of the sum of four angles and as such it may be expanded into the following form:

$$q = \begin{Bmatrix} \sin \omega t \\ \sin \omega t \\ \cos \omega t \\ \cos \omega t \end{Bmatrix} \begin{Bmatrix} \cos (k_1 \sin \mu_1 t) \\ \sin (k_1 \sin \mu_1 t) \\ \sin (k_1 \sin \mu_1 t) \\ \cos (k_1 \sin \mu_1 t) \end{Bmatrix} \begin{Bmatrix} \cos (A \sin \mu_2 t) \cos (B \cos \mu_2 t) - \sin (A \sin \mu_2 t) \sin (B \cos \mu_2 t) \\ \sin (A \sin \mu_2 t) \cos (B \cos \mu_2 t) + \cos (A \sin \mu_2 t) \sin (B \cos \mu_2 t) \\ \cos (A \sin \mu_2 t) \cos (B \cos \mu_2 t) - \sin (A \sin \mu_2 t) \sin (B \cos \mu_2 t) \\ \sin (A \sin \mu_2 t) \cos (B \cos \mu_2 t) + \cos (A \sin \mu_2 t) \sin (B \cos \mu_2 t) \end{Bmatrix} \quad (3)$$

where $A = k_2 \cos \theta$ and $B = k_2 \sin \theta$.

To facilitate future reference, eq. 3 is rewritten as follows:

$$q = \begin{Bmatrix} \sin \omega t \\ \sin \omega t \\ \cos \omega t \\ \cos \omega t \end{Bmatrix} \begin{Bmatrix} \cos (k_1 \sin \mu_1 t) \\ \sin (k_1 \sin \mu_1 t) \\ \sin (k_1 \sin \mu_1 t) \\ \cos (k_1 \sin \mu_1 t) \end{Bmatrix} \begin{Bmatrix} \text{I} - \text{II} \\ \text{III} + \text{IV} \\ \text{I} - \text{II} \\ \text{III} + \text{IV} \end{Bmatrix} \quad (4)$$

The sine and cosine functions of the expression $x \sin \varphi$ or $x \cos \varphi$ appear repeatedly in eq. 3. From any standard work on Bessel functions the following may be verified:

$$\begin{aligned} \cos (x \sin \varphi) &= J_0(x) + 2J_2(x) \cos 2\varphi + 2J_4(x) \cos 4\varphi + \dots \\ \sin (x \sin \varphi) &= 2J_1(x) \sin \varphi + 2J_3(x) \sin 3\varphi + 2J_5(x) \sin 5\varphi + \dots \end{aligned} \quad (5)$$

By substituting $\left(\frac{\pi}{2} - \varphi\right)$ for φ in eq. 4 one may obtain

$$\begin{aligned} \cos (x \cos \varphi) &= J_0(x) - 2J_2(x) \cos 2\varphi + 2J_4(x) \cos 4\varphi - \dots \\ \sin (x \cos \varphi) &= 2J_1(x) \cos \varphi - 2J_3(x) \cos 3\varphi + 2J_5(x) \cos 5\varphi - \dots \end{aligned} \quad (6)$$

The coefficients $J_n(x)$ are Bessel functions of the first kind, of order n and argument x . To substitute eq. 5 and 6 into eq. 3, x must be given three values: k_1 , $(k_2 \cos \theta)$, and $(k_2 \sin \theta)$. To simplify the resulting expressions, the following symbols will be employed:

$$\begin{aligned} K_n &= J_n(k_1) \\ M_n &= J_n(k_2 \cos \theta) \\ N_n &= J_n(k_2 \sin \theta) \end{aligned} \quad (7)$$

I in eq. 4 is expanded through the use of (5) and (6) as follows:

$$\begin{aligned} I &= [M_0 + 2M_2 \cos 2\mu z + 2M_4 \cos 4\mu z + \dots][N_0 - 2N_2 \cos 2\mu z + 2N_4 \cos 4\mu z - \dots] \\ &= M_0 N_0 - 2M_0 N_2 \cos 2\mu z + 2M_0 N_4 \cos 4\mu z + \dots \\ &\quad + 2M_2 N_0 \cos 2\mu z - 4M_2 N_2 \cos^2 2\mu z + 4M_2 N_4 \cos 2\mu z \cos 4\mu z - \dots \\ &\quad + 2M_4 N_0 \cos 4\mu z - 4M_4 N_2 \cos 4\mu z \cos 2\mu z + 4M_4 N_4 \cos^2 4\mu z - \dots \\ &\quad + \dots \\ &= O_0 + 2O_2 \cos 2\mu z + 2O_4 \cos 4\mu z + \dots \end{aligned}$$

where

$$\begin{aligned} O_0 &= M_0 N_0 - 2M_2 N_2 + 2M_4 N_4 - \dots \\ O_2 &= -M_0 N_2 + M_2 N_0 + M_2 N_4 - M_4 N_2 - M_4 N_6 + M_6 N_4 + M_6 N_2 - \dots \\ O_4 &= M_0 N_4 + M_4 N_0 - M_2 N_2 - M_2 N_6 - M_6 N_2 + M_4 N_6 + M_6 N_4 - \dots \\ O_6 &= -M_0 N_6 + M_6 N_0 + M_2 N_4 - M_4 N_2 + \dots \text{ etc.} \end{aligned} \quad (8)$$

In a similar manner, it may be shown that

$$\begin{aligned} III &= 2O_1 \sin \mu z + 2O_3 \sin 3\mu z + 2O_5 \sin 5\mu z + \dots \\ \text{where } O_1 &= M_1 N_0 + M_1 N_2 - M_3 N_2 - M_3 N_4 + M_5 N_4 + M_5 N_6 + \dots \\ O_3 &= -M_1 N_2 - M_1 N_4 + M_3 N_0 + M_3 N_6 - M_5 N_2 + \dots \\ O_5 &= M_1 N_4 + M_1 N_6 - M_3 N_2 + M_3 N_6 + \dots \\ O_7 &= -M_1 N_6 + M_3 N_4 + \dots \text{ etc.} \end{aligned} \quad (9)$$

$$\begin{aligned} II &= 2P_2 \sin 2\mu z + 2P_4 \sin 4\mu z + 2P_6 \sin 6\mu z + \dots \\ \text{where } P_2 &= M_1 N_1 + M_1 N_3 + M_3 N_1 - M_3 N_5 - M_5 N_3 + \dots \\ P_4 &= -M_1 N_3 - M_1 N_5 + M_3 N_1 + M_3 N_5 + \dots \\ P_6 &= M_1 N_5 - M_3 N_3 + M_5 N_1 + \dots \\ P_8 &= M_1 N_7 - M_5 N_3 + \dots \\ &\text{etc.} \end{aligned} \quad (10)$$

$$\begin{aligned} IV &= 2P_1 \cos \mu z + 2P_3 \cos 3\mu z + 2P_5 \cos 5\mu z + \dots \\ \text{where } P_1 &= M_0 N_1 + M_2 N_1 - M_2 N_3 - M_4 N_3 + M_4 N_5 + M_6 N_5 + \dots \\ P_3 &= -M_0 N_3 + M_2 N_1 + M_2 N_5 + M_4 N_1 - M_6 N_3 + \dots \\ P_5 &= M_0 N_5 - M_2 N_3 + M_4 N_1 + M_6 N_1 + \dots \\ P_7 &= -M_0 N_7 + M_2 N_5 - M_4 N_3 + M_6 N_1 + \dots \\ &\text{etc.} \end{aligned} \quad (11)$$

[One may add indefinitely to the foregoing expressions by observing certain rules:

(1) The sum or the difference of the M and N order must equal the O or the P order, as the case may be.

(2) Only odd orders or only even orders of M and N are involved in a given expression, and inspection of eq. 8, 9, 10, and 11 will give the key.

(3) All possible combinations of M and N orders consistent with the foregoing rules are included.

(4) All M orders have the positive sign; the N 's have the same signs as the J 's of the same order in expressions 6. The signs of all terms in eq. 8 and 11 are determined from this rule. The signs of the terms in eq. 9 and 10 result from the product of three factors: (a) (b) (c). (a) = ± 1 as determined by the rule just expressed for eq. 8 and 11. (b) = -1 if the difference between the N and M order is required to obtain the associated O or P order; otherwise it is $+1$. (c) = -1 if the M order is higher than the N order; otherwise it is $+1$.

Employing expressions 8, 9, 10, and 11 as well as 5 and 6, the expansion of 3 or 4 into trigonometric series may now be completed. The first step in the expansion results in terms consisting of products of sines or cosines or both of two or three angles. These may be finally expanded through the following trigono-

metric relationships. The right-hand side of each equation is a short-hand representation of the expression appearing between the two equality symbols.]

$$\begin{aligned}
 4 \sin A \sin B \sin C &= -\sin(A+B+C) + \sin(A-B+C) + \sin(A+B-C) - \\
 &\quad \sin(A-B-C) = \sum_{\pm}^{\pm} \sin(A \pm B \pm C) \\
 4 \cos A \sin B \sin C &= -\cos(A+B+C) + \cos(A-B+C) + \cos(A+B-C) - \\
 &\quad \cos(A-B-C) = \sum_{\pm}^{\pm} \cos(A \pm B \pm C) \\
 4 \sin A \cos B \sin C &= -\cos(A+B+C) - \cos(A-B+C) + \cos(A+B-C) + \\
 &\quad \cos(A-B-C) = \sum_{\pm}^{\mp} \cos(A \pm B \pm C) \\
 4 \cos A \cos B \sin C &= +\sin(A+B+C) + \sin(A-B+C) - \sin(A+B-C) - \\
 &\quad \sin(A-B-C) = \sum_{\pm}^{\mp} \sin(A \pm B \pm C) \\
 4 \sin A \sin B \cos C &= -\cos(A+B+C) + \cos(A-B+C) - \cos(A+B-C) + \\
 &\quad \cos(A-B-C) = \sum_{\pm}^{\mp} \cos(A \pm B \pm C) \\
 4 \cos A \sin B \cos C &= \sin(A+B+C) - \sin(A-B+C) + \sin(A+B-C) - \\
 &\quad \sin(A-B-C) = \sum_{\pm}^{\pm} \sin(A \pm B \pm C) \\
 4 \sin A \cos B \cos C &= \sin(A+B+C) + \sin(A-B+C) + \sin(A+B-C) + \\
 &\quad \sin(A-B-C) = \sum_{\pm}^{\pm} \sin(A \pm B \pm C) \\
 4 \cos A \cos B \cos C &= \cos(A+B+C) + \cos(A-B+C) + \cos(A+B-C) + \\
 &\quad \cos(A-B-C) = \sum_{\pm}^{\pm} \cos(A \pm B \pm C) \\
 2 \sin A \sin B &= -\cos(A+B) + \cos(A-B) = \Sigma_{\pm}^{\mp} \cos(A \pm B) \\
 2 \cos A \sin B &= \sin(A+B) - \sin(A-B) = \Sigma_{\pm}^{\pm} \sin(A \pm B) \\
 2 \sin A \cos B &= \sin(A+B) + \sin(A-B) = \Sigma_{\pm}^{\pm} \sin(A \pm B) \\
 2 \cos A \cos B &= \cos(A+B) + \cos(A-B) = \Sigma_{\pm}^{\pm} \cos(A \pm B) \quad (12)
 \end{aligned}$$

The final expansion results in a sine series and a cosine series:

$$q = q_1 + q_2 \quad (13)$$

$$\begin{aligned}
 q_1 &= K_0 O_0 \sin \omega t + K_0 O_1 \Sigma_{\pm}^{\pm} \sin(\omega \pm \mu_2)t + K_0 O_2 \Sigma_{\pm}^{\pm} \sin(\omega \pm 2\mu_2)t + \dots \\
 &+ K_1 O_0 \Sigma_{\pm}^{\pm} \sin(\omega \pm \mu_1)t + K_1 O_1 \Sigma_{\pm}^{\pm} \sin(\omega \pm \mu_1 \pm \mu_2)t + K_1 O_2 \Sigma_{\pm}^{\pm} \sin(\omega \pm \mu_1 \pm 2\mu_2)t + \dots \\
 &+ K_2 O_0 \Sigma_{\pm}^{\pm} \sin(\omega \pm 2\mu_1)t + K_2 O_1 \Sigma_{\pm}^{\pm} \sin(\omega \pm 2\mu_1 \pm \mu_2)t + K_2 O_2 \Sigma_{\pm}^{\pm} \sin(\omega \pm 2\mu_1 \pm 2\mu_2)t + \dots \\
 &+ K_3 O_0 \Sigma_{\pm}^{\pm} \sin(\omega \pm 3\mu_1)t + K_3 O_1 \Sigma_{\pm}^{\pm} \sin(\omega \pm 3\mu_1 \pm \mu_2)t + K_3 O_2 \Sigma_{\pm}^{\pm} \sin(\omega \pm 3\mu_1 \pm 2\mu_2)t + \dots \\
 &+ \dots \quad (13a) \\
 q_2 &= K_0 P_1 \Sigma_{\pm}^{\mp} \cos(\omega \pm \mu_2)t + K_0 P_2 \Sigma_{\pm}^{\mp} \cos(\omega \pm 2\mu_2)t + K_0 P_3 \Sigma_{\pm}^{\mp} \cos(\omega \pm 3\mu_2)t + \dots \\
 &+ K_1 P_1 \Sigma_{\pm}^{\mp} \cos(\omega \pm \mu_1 \pm \mu_2)t + K_1 P_2 \Sigma_{\pm}^{\mp} \cos(\omega \pm \mu_1 \pm 2\mu_2)t + K_1 P_3 \Sigma_{\pm}^{\mp} \cos(\omega \pm \mu_1 \pm 3\mu_2)t + \dots \\
 &+ K_2 P_1 \Sigma_{\pm}^{\mp} \cos(\omega \pm 2\mu_1 \pm \mu_2)t + K_2 P_2 \Sigma_{\pm}^{\mp} \cos(\omega \pm 2\mu_1 \pm 2\mu_2)t + K_2 P_3 \Sigma_{\pm}^{\mp} \cos(\omega \pm 2\mu_1 \pm 3\mu_2)t + \dots \\
 &+ K_3 P_1 \Sigma_{\pm}^{\mp} \cos(\omega \pm 3\mu_1 \pm \mu_2)t + K_3 P_2 \Sigma_{\pm}^{\mp} \cos(\omega \pm 3\mu_1 \pm 2\mu_2)t + K_3 P_3 \Sigma_{\pm}^{\mp} \cos(\omega \pm 3\mu_1 \pm 3\mu_2)t + \dots \\
 &+ \dots \quad (13b)
 \end{aligned}$$

[Terms may be added indefinitely to the two-fold infinite series (13a) and (13b) by observing that

(1) the coefficient of μ_2 increases by 1 per term as progress is made to the right; the coefficient of μ_2 increases by 1 per term as progress is made downward; and

(2) where four + or - signs follow the sigma, it will be observed that they appear in two arrangements in a given line or a given column. These two arrangements alternate across the page and downward.]

In the solution of a problem, terms must be evaluated until $K_n P_m$ or $K_n O_m$ become negligible in value.

When $\theta = 0$, $N = 1$ and all other N orders are zero. Hence from eq. 10 and 11 all orders of P are zero, and $q_2 = 0$.

When $\theta = \frac{\pi}{2}$, $M_0 = 1$ and all other M orders are zero. Hence the odd-order

O 's and the even-order P 's become zero, and expressions 13a and 13b are accordingly simplified and the series converge more rapidly.

Each term in eq. 13a and 13b represents four frequencies: $\frac{1}{2\pi}(\omega + a\mu_1 + b\mu_2)$, $\frac{1}{2\pi}(\omega - a\mu_1 + b\mu_2)$, etc. In some cases two or all four of these may be equal.

When a harmonic relationship exists between μ_1 and μ_2 , a considerable number of terms from eq. 13a or 13b or both may enter into the evaluation of the amplitude at each frequency. If q_2 is not equal to zero, the total amplitude at each frequency is made up of a number of sine components from 13a and a number of cosine components from 13b. In this case the modulus at the frequency in point is

$$S_n = \left(\frac{\text{sum of contributions}^2}{\text{from 13a}} \right) + \left(\frac{\text{sum of contributions}^2}{\text{from 13b}} \right)^{1/2} \quad (14a)$$

The phase-angle of the component having the frequency in point is

$$\theta_n = \tan^{-1} \left(\frac{\text{sum of contributions from 13a}}{\text{sum of contributions from 13b}} \right) \quad (14b)$$

A property of eq. 13a and 13b that proves valuable in providing a check on computations is the fact that the sum of the squares of the total amplitudes at each frequency is equal to 1. This is equivalent to observing that the modulus of q is 1, which follows from its definition 1.

REFERENCES

- ¹ VAN DER POL, B.: "Frequency Modulation," *Proc. I. R. E.*, **18** (July, 1930), p. 1194.
- ² RODER, H.: "Amplitude, Phase, and Frequency Modulation," *Proc. I. R. E.*, **19** (Dec., 1931), p. 2145.
- ³ SHEA, T. E., MACNAIR, W. A., and SUBRIZI, V.: "Flutter in Sound Records," *J. Soc. Mot. Pict. Eng.*, **XXV** (Nov., 1935), p. 403.
- ⁴ BARROW, W. L.: "The Multitone," *J. Acoust. Soc. of Amer.*, **10** (April, 1939), p. 275.
- ⁵ BARROW, W. L.: "On Interference Elimination with The Warble Tone," *J. Acoust. Soc. of Amer.*, **3** (1932), p. 562.

SCIENCE AND THE MOTION PICTURE*

HENRY ROGER**

Summary.—The motion picture is a product of science. There is ample historical material available for those who wish to convince themselves of this fact, but a brief review is given of the work of Muybridge and Marey in order to clarify the cause of their inventions. The ensuing discussion centers around the question, "Has science maintained its interest in the motion picture and has it utilized its advantages to its full extent?"

In this paper the word "science" is taken broadly and includes research, dissemination of knowledge, and industrial application. Motion picture's application to science is divided into two distinct categories and are discussed in detail:

(1) The motion picture as an aid to scientific research;

(2) The motion picture as a medium for the dissemination of knowledge.

The paper concludes with descriptions and demonstrations of interesting material from the files of the Rolab Photo-Science Laboratories. Also an inside view is given of production activities of an unusual character.

As we all know, the motion picture is a product of science. The names of Muybridge and Marey are familiar to us and we do not need to go into detailed discussions and biographies. There is ample material available for those who wish to obtain more information about the origin and history of the motion picture. However, let us refresh our memory for a moment in order to examine the actual cause of these early inventions of 50 years ago.

Necessity is the mother of invention, as we have been told. We might add here human curiosity as a possible incentive of invention. This certainly was the case with Muybridge, the photographer, who wished to find out whether or not a galloping horse leaves the ground momentarily. We know the way in which he solved this problem, as well as other problems which came up in the field of animal and human locomotion, not realizing at the time that the battery of 24 cameras which he used would give rise to the motion picture industry as we know it today.

Professor Marey, the physiologist, also tried to solve his scientific problems of men and animate and inanimate matter, with the aid of

* Presented at the 1939 Fall Meeting at New York, N. Y.

** Rolab Photo-Science Laboratories, Sandy Hook, Conn.

photography. However, in place of Muybridge's 24 cameras he employed a single camera with a rotating shutter producing a single negative with multiple exposures of the object moving across the field. Later Marey devised a photographic gun to study birds in flight, in which the mechanical principles of the modern motion picture camera were incorporated.

The question may now be asked, has science maintained its interest in the motion picture and has it utilized its advantages to its full extent? The answer is "NO!" For approximately thirty years science, which

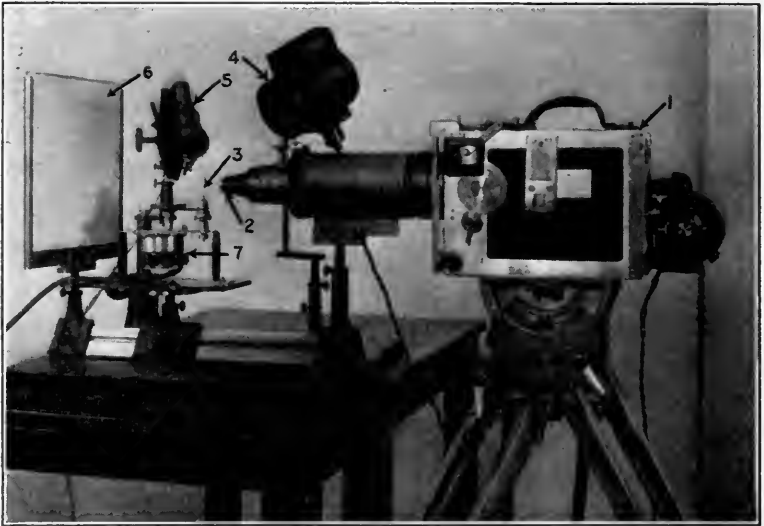

FIG. 1. Taking motion pictures of a carbon particle on the point of a needle. (1) Camera, (2) objective, (3) carbon particle on needle, (4) (5) light-sources, (6) back drop, (7) rotating device.

here includes education, did not avail itself of the motion picture. Only within the last fifteen to twenty years have scientists and educators begun to use motion pictures again, with reluctance to be sure, which today has not been overcome.

Let us now review the advantages that the motion picture has to offer in the field of science, "science" to be understood in its broadest meaning. For the sake of clarity let us divide the application of motion pictures into two categories:

- (A) The motion picture as an aid to scientific research.
- (B) The motion picture as a medium for the dissemination of knowledge.

(A) Let us consider the first item. It has been realized since its invention that the motion picture has made us masters over the elements of time. We can do with time as we can do with space with the aid of telescopes and microscopes. In other words, the motion picture is a tool that permits us to investigate phenomena invisible to the unaided eye, because they may be too fast or too slow or they

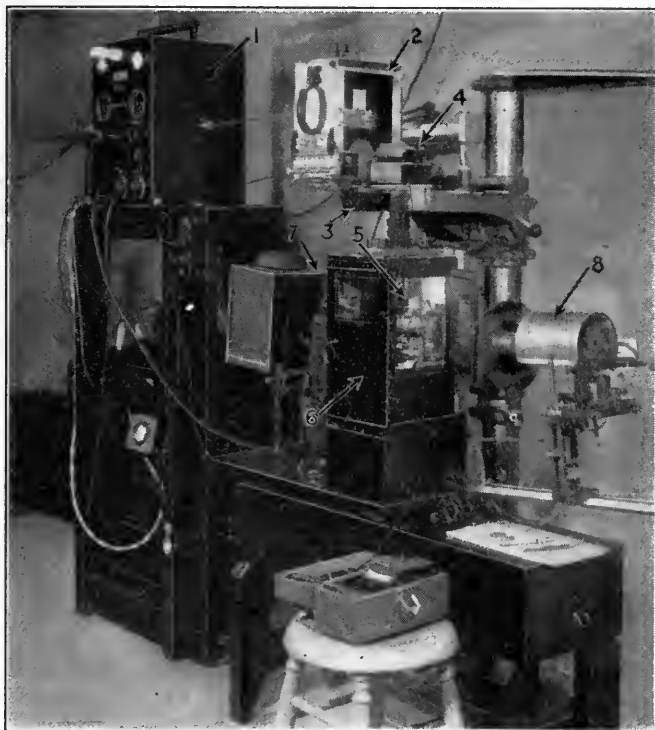

FIG. 2. Complete microcinematographic apparatus. (1) Camera timer with motor, (2) camera, (3) observation piece, (4) focusing device, (5) microscope, (6) incubator, (7) incandescent lamp, (8) arc lamp, (9) electric exposure meter.

may also be outside of the visible region of the spectrum. In class A above we have at our disposal:

- (1) High-speed motion pictures (slow-motion),
- (2) Normal-speed motion pictures,
- (3) Time-lapse motion pictures,
- (4) Selective spectra motion pictures, such as ultraviolet, infrared, x-ray, etc.

(B) Now we come to the second item, the motion picture as a medium for the dissemination of knowledge. Motion pictures falling into this category are obviously entirely different from the ones just discussed, although it may be stated that much of the material belonging in the first category may well be used in the second.

The status of informative motion pictures is indeed very complex. Judging from the many lists and catalogues in circulation there seems to be already an enormous wealth of material available. However a closer study of this material may lead one to the conviction that a great majority of the films are lacking in quality, editorial as well as photographic. They are therefore of little value. On the other hand, there are a number of excellent films in circulation that should be taken as examples by those who produce such films.

It is not the purpose of this paper to analyze in detail the merits and faults of the available motion pictures. This should be done rather by those who use them, and it is to be wished that constructive criticism were given more freely and so made available to the producers.

Let us now examine the agencies where scientific motion pictures are made. Among them are

- Scientific institutions, laboratories, universities, museums, associations
- Motion picture concerns with special departments
- Governmental departments, Federal and State
- Industrial concerns making films mainly to advertise their products
- Manufacturers of motion picture equipment
- Private groups
- Individual scientists and educators

The interests and purposes of these groups differ widely; hence the difference in type and quality of pictures produced by them is very great, indeed. For this reason an impartial board of review whose business it would be to evaluate all films submitted and to put their stamps of approval on films of real scientific value, would serve a good purpose and at the same time would save a great deal of time and effort for the users of films who have to select their films from lists, and do not know their quality. Such a board would be of help in raising the standard of film quality. In spite of the present achievements, we may still consider the production of scientific films to be in its beginning, and much work remains to be done to fulfill the need for a fairly complete library. Furthermore, very little has been done so far in the field of advanced learning. We are in need of material giving more exhaustive information on special subjects, such as are

available in scientific books. Because of the fact that too many films are general and elementary in character the motion picture is not as yet a matter of importance to quite a number of scientists.

I should like now to discuss some of the more technical phases and to give here an inside view into some production activities of an unusual character, taken from the files of the Rolab Laboratories.

The general routine of production in the scientific field is the same as in the entertainment field. However, the script is very likely subject to constant changes and modifications, brought about by the outcome of experimentation. Here is a typical example of the amount of work that might be required. A script calls for a scene in which germs are shown being killed by a germicide. Manufacturers of chemicals, tooth paste, mouth washes, foods, refrigerators, containers, *etc.*, always seem to have this subject in mind. This appears to them a very simple matter. One has only to put under the microscope a few of the many billions of bacteria which are supposed to be menacing humanity on all fronts. Next we add the germicide, one of the many that are widely advertised and obtainable in any drugstore. Now one should see that spectacular phenomenon—the destruction of the germs.

Here is a summary of the actual procedure:

It is assumed that the operator has a good knowledge and practical experience in bacteriological technic. It is also assumed that he has at his disposal an array of standard bacteriological equipment—glassware, incubator, platinum-loops, Bunsen burner, sterilizer, *etc.* Instead of starting and isolating his own bacterial cultures, which would require a great deal of extra time, he would purchase a culture from a type culture collection. Then he would prepare the culture medium best suited for this particular experiment, and also for good photography, and start subcultures in order to have fresh material at hand for each new experiment. He now prepares a typical micro slide for observing the bacteria under the microscope. A few words about bacteria might be of interest. Many persons seem to believe that bacteria when seen through a microscope look like lice or worms crawling about. The fact is that most of them do not move at all, are extremely small, and are hardly visible at the highest magnification. Even experts often can not tell whether they are alive or dead. Their shapes are simple—little rods, dots, spirals, chains. Motile bacteria, such as typhoid, may move, however, very rapidly.

Continuing his experiments the operator now tries to add very carefully, with a small pipette, a minute drop of the germicide, whatever it may be. We assume that he has found a group of bacteria that show up very clearly. To his dismay, the operator will find upon adding the germicidal fluid his whole field blurred, the bacteria gone. The use of high-powered objectives, with their extremely small depth of focus, measured in microns, leaves little chance of success for this experiment. The slightest touch or even a change in temperature will cause a change in focus.



FIG. 3. Apparatus set-up for taking motion pictures of microscopic phenomena at very low temperatures. (1) Camera timer with motor, (2) camera, (3) microscope, (4) freezing chamber on microscope, (5) freezing apparatus, (6) light-source

This work might go on for days or weeks, until a way may perhaps be found to show the desired scene, by means of a new technic with a moist chamber in conjunction with micromanipulation. However, to take motion pictures we have not only to control the action with regard to time, but also to take precautions with regard to light and heat.

The operator proceeds with his photographic problems, and we

assume that he has his complete microcinematographic apparatus carefully adjusted and ready, with his microscope inside an incubator regulated for 37.5°C . We shall not describe here the various parts that have to be manipulated. The operator makes his exposure tests with the aid of a test specimen and the exposed strips of film, having been developed in the darkroom, are then examined with a strong magnifying glass.

Again we assume that all went well and that the intense light as well as the heat, reduced by proper filters, has done no damage to the specimen. It may be mentioned that all microorganisms prefer darkness for best conditions.

Skill, perseverance, and good luck may finally produce the desired result in the form of a certain length of film which will later be a part of the completed motion picture. This is not all fiction: A motion picture actually exists of this phenomenon under the title, *Action of Bacteriophage upon Bacterium Coli*. This film was made about 10 years ago with the collaboration of Dr. Bronfenbrenner at the Rockefeller Institute.

Taking another typical example, scenes might be required showing a living insect. Most of such shots are made at close range so that the image on the film is either slightly reduced in size, of natural size, or enlarged up to 10 times, depending upon the details desired. Many persons believe that this kind of photography is much simpler than working through a microscope at $1000\times$ magnification. Those who have had experience will believe otherwise. Some say that this work is even more difficult. Let us consider some of the problems: Most microscopes are designed for high magnification. The size of the object is limited, and may not be larger than the aperture diameter of the substage condenser. Most objects for the microscope are practically transparent. On the other hand, small objects, such as insects, being opaque, require surface illumination. Therefore the small spotlights used for this purpose have to be arranged similarly to those in a studio, although within a very narrow space.

Although microscopes may be used for this type of work and there is some special equipment available, flexibility is lacking when we come to photographing living objects. For years our laboratory has paid special attention to this kind of work, known as "photomacroph," and we have developed an equipment consisting of about 150 parts which may be arranged to suit various purposes and taken apart after the job is completed. Here again, as in all close work, the

lack of depth of focus presents difficulties. Let us again take the insect as an example. In order to get all parts sharply into focus we may have to work with objective apertures of $f/32$ or even $f/64$. This requires a very intense illumination, considering the short exposures necessary (about $1/60$ sec.), and if not cooled down with heat absorbers, the heat so created would burn the insect within a second.

Another point of consideration is the elimination of vibration. In order to obtain sharp negatives the object must be placed upon a rigid stand or holder. The lens should have no mechanical connection with the camera which, having moving parts in its interior, would otherwise cause vibrations in the objective.

To obtain the utmost in sharpness our laboratory has a special macrophotographic studio with a floor of poured concrete 13 by 33 by 3 feet thick, upon which the equipment stands. The building is located $1\frac{1}{2}$ miles from the nearest traffic.

In all this type of work, dealing with living material, we encounter a variety of problems. Our tiny actors on the stage of the microscope are often many times as temperamental and as difficult to handle as those in Hollywood. In contrast with still photomicrography, which has become a matter of routine in many laboratories, micro motion pictures almost always have to deal with living or at least moving objects which, considering their size and delicacy, require extreme care. The slightest change in environment, light, heat, composition of medium, radiations, shock, bacterial infection, all have to be taken into account. The cultivation of living tissue, for example, offers many such problems. It has even been found here that certain types of glass, such as ordinarily used for preparations, have toxic effects. The composition of the glass in this case becomes almost as important as in the construction of photographic lenses.

A motion picture we made some time ago of budding yeast, starting with a single cell which developed into hundreds of cells, caused us much labor. The script called simply for a scene 50 to 60 feet long. On various tests we found that it would take six to eight hours for a yeast cell to develop into a group filling the entire field. We also made preliminary experiments with regard to a proper medium in which the cells would stay in focus and not move or shift. Further tests were made with regard to light and heat. Then we began to take pictures.

The trouble with the yeast cells is that they do not show whether they are alive or dead. After hours of shooting, frame after frame,

we often had to give up further work because the cells had died. The following day we had to start a new culture again. After many such attempts we finally succeeded in obtaining a fine record of the budding process, having by that time found the correct combination of light filters which did not interfere with the growth and the proper photographic material.

One may think perhaps that lifeless material may not lend itself for motion picture subjects; yet we have done a great deal of motion picture work with inanimate matter. For an industrial picture dealing with carbon we have taken scenes demonstrating dry flocculation of carbon particles as well as the agglutination of particles in liquid suspensions. We have balanced a single carbon particle upon a pin-point, and have taken a picture of it while the pin was rotated. This required a rotating device built with precision, as the slightest inaccuracy would have moved the object out of the field at such high magnification.

For several films on colloid chemistry we have been very successful in obtaining good film records of the Brownian movement of ultra-microscopic particles. These particles, smaller than the wavelength of light, can not be seen in the most powerful microscopes except by indirect illumination, the principle of the ultra-microscope. This principle may be compared with a beam of sunlight entering a darkened room through a narrow opening. What we actually see are the reflections of dust particles floating in the air, which in ordinary light would be invisible. We have made other pictures of colloidal gold, silver, copper, arsenic, manganese, and sulfur, and also the carbon particles suspended in india ink; also colloidal particles floating in the fluids of the human eye. We have succeeded in taking motion pictures of single particles of cigaret smoke floating in air. They look like small globules. For this purpose we constructed a small chamber that fitted into the microscope, through which smoke was blown through small openings.

To show the precipitation of rubber latex we injected a small amount of acid into a drop of latex by means of a micro pipette operated with a micromanipulator. The pictures of this action are quite spectacular. Other experiments, recorded in motion pictures, were the making of colloidal silver with the electric arc, the cataphoresis of colloidal particles showing their migration in the electric field, the process of coagulation, the swelling of glue and gelatin, *etc.*

Recently we were called upon to take motion pictures of various objects subjected to high as well as to low temperatures. For the high temperatures we built a miniature furnace having a window through which we photographed various kinds of borax crystals and other substances. Pictures were taken of a variety of objects subjected to gradually diminishing temperatures.

In a patent infringement case dealing with the manufacture of ice cream confections we had to demonstrate various phenomena taking place in the molds at various degrees. We obtained beautiful pictures of the formation of ice crystals and also capillary actions in wood and paraffin.

Several reels of film were projected in court and accepted as evidence, which in itself may be considered significant for the future use of motion pictures for legal purposes.

The equipment used for this work had, of course, to be specially constructed in such a way as to permit careful control of the temperature. It consisted of a freezing chamber through which a refrigerant was circulated, and a cooling unit, a liquid-air container with a copper coil inside. The chamber was fitted to the microscope with an opening for the light to enter from below and another opening for the objective to enter from above. The preparation had to be completely enclosed in order to prevent condensation of moisture on the surfaces of the optical system. Naturally, depending upon the temperature desired, we employed various refrigerants and cold-producing agents such as compressed carbon dioxide snow, usually known as "dry ice."

A similar set-up was used to show the formation of wax crystals in various motor oils for a motion picture for one of the largest oil concerns in the country. The picture was made to demonstrate what happens in a drop of motor oil when subjected to intense cold. In one type of oil we saw large elongated crystals forming interlocking networks, causing the oil to become solid or semisolid, thus preventing the motor from starting. In another type of oil the crystals remained small and isolated from one another at the same low temperature, proving that this oil remains liquid and permits easy starting. For these experiments we had to use polarized light. A Nicol prism representing the polarizer was fitted into the freezing chamber and another Nicol prism acting as analyzer was placed in the microscope tube immediately above the objective.

One interesting problem had to do with focusing. First, we had to

use high magnification with extremely small depth of focus; second, we had to focus upon a plane in the specimen that was invisible at room temperature but at which the crystals were to appear quite suddenly in the form of very small dots when the freezing point was reached. This problem was solved by making the system reversible. We focused on the crystals as soon as they appeared and went back to room temperature to start taking pictures. However, we had to make allowances for expansion and contraction in the microscope set-up.

Further descriptions of unusual motion pictures could be given, but enough has been said for the present purpose.

It is gratifying to me not only to witness the increase of interest in the use of motion pictures in science—including industry and education—but also to have taken part in this development. When I began my work at the Rockefeller Institute after the World War, the making of motion pictures was considered by most scientific workers as a hobby, certainly not much respected as a scientific tool. However, as soon as films of living cells made their appearance at staff meetings, showing the structure and behavior of these cells in a realistic way as had never been possible before, the disregard turned into enthusiasm. This was especially true at the time when we could claim discoveries, made through motion pictures, in the structure of white blood corpuscles, such as a presence of a membrane surrounding each cell.

The films of living cells have been demonstrated at many scientific meetings, here and abroad; however, for reasons not quite understandable the Institute has not permitted the films to be copied and distributed for the benefit of schools and universities. It is to be regretted that many requests for demonstrations have always been turned down.

No attempt has been made in this paper to cover the entire field of science. To do so would fill many volumes. There are hundreds of laboratories today in which motion picture cameras have found uses to a greater or less extent. I have not discussed the use of the motion picture in practical medicine and surgery, a field which today, thanks also to the availability of 16-mm equipment and color stock, has found wide applications;¹ nor have I treated here the use and the accomplishments of high-speed motion pictures² (or so-called slow-motion pictures), or of astro-photography.

Interesting discoveries are in store when the electron microscope is

put to use and perhaps hooked up with the motion picture camera.

I can not leave these technical discussions without mentioning a few amusing inquiries I have received from time to time. A manufacturer of tooth paste wished to show in motion pictures the germ-killing action of his product. After showing him what germs looked like through a microscope at high magnification, he insisted that I use paramecia or slipper animals, which live only in ponds and lakes, and which some schoolboy may have shown him through a magnifying glass. These seemed to explode when a drop of soap solution was added.

The subject of paramecia reminds me of a film I saw about Leeuwenhoek, the inventor of the microscope, who lived about 250 years ago. To demonstrate the terrible germs, menacing humanity, Leeuwenhoek suddenly turned toward one of the guests in his room, made him open his mouth, took an instrument the size and shape of a screw driver, and manipulated it as a dentist would use a forceps when extracting a tooth. The guest was terrified when the germs were pulled out of his mouth "without anesthesia." Then Leeuwenhoek examined with his simple microscope his find on the end of his instrument—lap-dissolve—"Paramecia or Slipper Animal."

Another tooth-paste manufacturer, who added some colloidal metal to his product, requested me to photograph a tooth having a cavity, and at the same time to show the metal particles bombarding the germs and food particles. A manufacturer of face preparations added colloidal gold to face cream and wished to show the Brownian movement of the gold, which he had somewhere heard about. The particles at the same time should enter the pores of the skin and remove the dirt collected therein. Many requests for photographing atoms and molecules had likewise to be turned down.

The purpose of this paper is to call attention to and to emphasize the wider use of motion pictures in fields of science in which they may serve a real purpose, aside from merely entertaining someone. As we have seen in the beginning, science has a good right to claim motion pictures as its own. Naturally, it is not to be expected that all film-producing agencies will be able to make good films requiring a great deal of technical experience and specialized equipment. Indeed, there exists a lack of skilled men who are motion picture experts as well as scientists. To fill this vacancy the Rolab Laboratories were established for the purpose of assisting and collaborating with others in the production of scientific motion pictures by utilizing

their experience and elaborate and unique equipment, and so save time and expense to those with less or no experience and equipment. Plans are also under way to train individuals in the making of scientific films.

REFERENCES

¹ ROGER, H.: "New Uses of Sound Motion Pictures in Medical Instruction," *J. Soc. Mot. Pict. Eng.*, XXXII (May, 1939), p. 527.

² ROGER, H.: "A New Camera Timer for Time-Lapse Cinematography," *Ibid.*, XXXII (May, 1939), p. 549.

THE PRESERVATION OF HISTORY IN THE CRYPT OF CIVILIZATION*

T. K. PETERS**

Summary.—The problems confronting the scientist who inaugurates the unique task of preserving in film for the people of the 80th century a complete picture of our life in America today; the problem of the life of film, and of its relationship to ancient papyrus that has come down to us over sixty centuries; the method of preserving it; the microfilming and preparation of the records; the making of a duplicate film on metal; and the entire scope of the project is set forth and discussed.

What would you do if you were confronted with the problem of preserving for the people of the world six thousand years from now a complete picture of our life, civilization, and culture of today? This question impressed me forcibly when I read some two years ago that Dr. Thornwell Jacobs, President of Oglethorpe University near Atlanta, Georgia, proposed to do this very thing. The idea struck me as being both unique and practicable if it was not just a publicity stunt, for in my experience as a motion picture cameraman during my travels to all the strange places of Asia and North Africa, I had often stood and pondered in some ancient and forgotten city and wondered why there was no record of its people and their life. During my life I have visited the photographed Chichen Itza, Petra, Baalbek Anuradhrapura, Amber, Golconda, Angor Wat, Karnak, and many another desolation of stone that had once been a great city. I thought of Tut-Ankh-Amen's tomb and the great store of material contained therein, a store of treasure regarding the life of the king and of his stately splendor, but nothing of his people, their lives, their thoughts, and their knowledge. So, when I saw the article in the *Scientific American* announcing the idea of the Crypt and asking for suggestions, I sat down and from my experience as an archaeologist, wrote Dr. Jacobs what I thought ought to be put into the Crypt. I wrote a twelve-page letter based upon both my experience as a mo-

* Presented at the 1939 Spring Meeting at Hollywood, Calif.; received March 17, 1939.

** Oglethorpe University, Ga.

tion picture technician and as a student of the past. Dr. Jacobs invited me to come to Oglethorpe and talk the project over with him, and as a result of my visit, asked me to take charge of the collection and preservation of the materials to be placed in the Crypt. So then, from merely speculative contemplation of the project I was confronted with the myriad details of the actual work. This, however, did not present anything that a motion picture technician should be afraid of, for we are all called upon every day to do or create miracles in our daily work, and as my motion picture experience had been preceded by a thorough grounding in physics and science generally, I welcomed the opportunity. So that is how I happen to be now doing the work of an archaeologist of the eightieth century, anticipating his every desire for knowledge in regard to life in America today. With this introduction to the history of the Crypt of Civilization, as it is called, let us see what technical problems are involved in carrying it out.

The first issue involved was that of finding out what kinds of materials would survive the march of the centuries—sixty of them—that would elapse between the closing of the Crypt and its opening in the year 8113 A.D., a period as far in the future as our first recorded date in the past. Going back to the past and taking my own experience and the work of every scientist who could throw light upon the subject, I endeavored to find what had survived the period of time contemplated. The most helpful work was that of the scientist-archaeologist, Lucas, whose analysis of objects taken from ancient Egyptian tombs was both practical and scholarly. Then followed the making of a list of objects and substances that have come down to us comparatively intact *without any conscious effort at preservation*. This list includes stone, clay objects, wood, bone, glue, leather, linen, rag paper, copper, gold, silver, pitch, and glass, as well as minor materials. So you see we have quite a list of possible materials to work with. As practically all paper used in books and newspapers today is made from woodpulp, which is not stable, and, in fact, will not last a century, this of course must be ruled out. Then how were we to preserve all the knowledge contained in books? Knowing that our new cellulose acetate film had a life span equivalent to that of rag paper, and knowing that the ancient Egyptian papyri were nothing more than rag paper and that one of them, the Papyrus of Nu, is now nearly 4000 years old, it was but a step in reasoning to assume that cellulose acetate if properly prepared and finished would, under the

scientific method we should adopt, be preserved in splendid shape. Then, too, we had a metal on our list that would remain fairly stable (copper) and by combining this with a greater percentage of nickel so that a white metal resulted, from tests made we found that this would undoubtedly last the sixty centuries and come through unscathed. So we decided to make two sets of records, one on metal and one on cellulose acetate. The cellulose film record is being made on regular 35-mm duping positive, which is given an extended washing after fixing, then neutralized and washed again. When thoroughly dry, it is put into a vacuum machine and treated with the "vaporate" process which coats the gelatine emulsion and penetrates it with a hard yet flexible coat of varnish. Photographing upon this film with a microfilm camera of my own design, utilizing images double the motion picture frame size, we are making a record of one thousand works covering the entire essential knowledge of the world in every branch. Each of the books is an authority on some particular field of study and embraces all that we know of science, art, religion, philosophy, sociology, useful arts, philology, and general works such as the *Encyclopedia Britannica*, *Compton's World Book Encyclopedia*, dictionaries of all modern and some ancient languages, and specific encyclopedias on various subjects such as photography, costumes, automobile engineering, medicine, radio, etc. These when photographed, printed, and processed are put into 100-ft rolls, and eight of these are placed in a glass cylinder closed at one end and with spacers of glass between each roll of film. When the cylinder is full it is sealed except for a small tubulation extending from the sealed end. This is inserted into the manifold of a vacuum pump and the air in the cylinder is exhausted to 3 microns, after which helium is allowed to enter and the tubulation is then sealed off, leaving the film in an atmosphere of helium containing sufficient moisture to keep it in a flexible condition during the time it is sealed up. This process finished, the glass cylinder is slipped into an asbestos transite cylinder, which in turn is sealed off at both ends and then this is enclosed in a stainless steel cylinder with a positive closure which is soldered up. Preserved in this manner from contact with the air, and protected from fire, moisture, cold, or insects, the film will come through intact. The metal film is prepared by a combination of new and old processes. Some years ago I became interested in the use of metal film but quickly realized that its use in theaters, while advisable on account of fire hazard, was not practicable inasmuch as it would have neces-

sitated making radical changes in the projection equipment to obtain a result that never could equal projection *through* the film. For this reason it would never be adopted by the industry in general. As a means of preserving historical records, however, it has a definite place and when I became associated with the work at Oglethorpe University, I revived my original metal film procedure and prepared to make the necessary records on metal. To do this I have evolved an original formula, the only one in the process, but one that is essential to the success of metal film for historical preservation. The formula in question is for sensitizing the metal with an almost instantaneous sensitizer allowing the printing of motion pictures on long strips of 35-mm metal as rapidly as it can be done by the ordinary photographic process used. The difference between this and the ordinary emulsion, however, is in the fact that when my emulsion has been exposed to light it becomes hardened and will act as a resist, so that the portions that are affected by light can be etched by acid to any depth required. It has been possible to do this, of course, for a long time in fact, every halftone cut is made by this process. But printing on metal up to the time of my discovery took several minutes for each exposure, hence would be of no value in making the hundreds of exposures necessary to make even a roll of 100 ft of film. Hence, all processes for the use of metal film have used an ordinary photographic emulsion coated on the metal, printing the image in the ordinary way, fixing, and washing. This, of course, would be subject to all the faults of stripping, *etc.* In my process, the portions not affected by light—the image, in other words—are left in the raw metal, and this is etched to a depth of 0.0002 inch and in the place so etched new metal of a contrasting color is deposited. This may be oxidized silver, black nickel, or black platinum. The amount used is so negligible that cost is not a factor. When the deposit is finished, the resist is removed by a chemical solvent, leaving the image in black on the white surface of the base nickel, and in a form that can not be washed off or eradicated except by abrading the metal itself. It can be further protected by a coating of cellulose acetate or one of the methacrylates and should last ten thousand years when protected in the same manner as the cellulose film, namely, in cylinders from which the air has been excluded and replaced by helium.

By either or both of the methods described, of course, the complete history of the United States which I have accumulated in contemporary photographs will be recorded. In motion pictures we shall

have a pretty complete history since 1897, beginning with the inauguration of President McKinley, and covering every salient feature of history as it occurred. As the metal film will also take the sound-track, from which the sound can be reprojected by reflection by means of a special projector I have devised, the voices and images of all our great men will be immutably preserved for the people of the future. Motion pictures are in both 16-mm and 35-mm sizes, and are preserved in a special container having globular ends to withstand the pressure when the container is evacuated. Otherwise they will be encased in both the transite and stainless steel containers in the same manner as the microfilmed records. The entire microfilmed record and motion picture deposit will take up only about 250 cubic-feet of space in the Crypt out of a total space of 2000 cubic-feet. Thus there will be ample room for the many other interesting deposits that will go to compose the entire picture. There is a section devoted to plastics, those wonderful substances, man made, which have only come into existence during the last twenty-five years. In this section, which has been accumulated through the courtesy of Dr. Baekeland and his staff, are all kinds of objects in use in our daily life, such as an electric razor, an electric iron, a toaster, a radio, an electric clock, and many other interesting developments made from bakelite, catalinite, tenite, vinylite, plexiglas, micarta, and other combinations of synthetic resins so extensively used today. Samples of cloth of various kinds from the finest to the coarsest, and plain, printed, and embroidered, are sealed in glass containers also. Little manikins dressed in characteristic costumes of men and women of this day will also be placed in glass containers. Models of all our great inventions such as locomotives and cars, refrigerators, printing machines, tabulating machines, the cotton gin, automobiles, aeroplanes, and things of this nature made in miniature form and to exact scale will be included as well as blueprints from which they may be reconstructed in case civilization has gone back to primitive times. Many actual articles which from their ephemeral nature would undoubtedly be lost will also find a place in the Crypt. These will include a lady's handbag, containing all the gadgets that the normal bag holds, such as lipstick, compact, keys, hairpins, *etc.*, as well as many other objects in common use. Artificial aids to hearing and eyesight, an artificial skull, artificial eyes, arms, legs, and teeth will give our descendants in the one hundred and eighty-seventh generation some idea of the method by which we repaired natural defects or losses. In order that all the mo-

tion pictures and other objects contained in the Crypt may be made available, projectors for sound and silent film, as well as by reflection, for the metal film, will be placed in with the film; and so that the many instruments and utensils can have the proper kind of current, a wind-driven generator made of permalloy will be on hand ready for use when the Crypt is opened. In case the English language is no longer in use, a special machine has been devised by me so that a knowledge of the English language may be achieved. The basis of the machine is an old mutoscope. To this is attached a phonograph by means of shafting and a heavy flywheel. On the shaft is fastened a small generator which delivers 12 volts, supplying current for a small lamp just inside the machine. On the top of the machine is a strip picture showing clearly that to use the machine all you have to do is to turn the crank. On looking into the machine a motion picture is shown of a man holding up various objects and doing various things; for example, he holds up an apple and says "apple," and underneath the object is printed the word, while the sound comes out of the speaker. You see a pair of legs running and the word "running" is pronounced and spelled for you, and so on. In this way 1500 basic English words prepared by the Orthological Institute of London are made possible without effort spent in deciphering and learning them. In addition, of course, the pronunciation is given, for even if English is common in that day, the sound will be probably as different as the sound of the English of Chaucer now is to us. We are preparing two sets of plates, one for Asia and one for the European and Western countries. On each of these will appear the complete story of the Crypt, what it will contain, and its exact location according to the Coast and Geodetic Survey and in relationship to Stone Mountain not far away. The Asian tablet will bear upon its surface the story in Chinese, Japanese, Maharatta, Telugu, Hindu, Urdu, and Sanscrit. The tablet for Europe and America will tell the story in English, French, Spanish, Portuguese, Italian, Russian, and Scandinavian so that one of these tablets will be sure to be found and point the way to the treasurehouse of knowledge. These tablets will be sent to libraries, universities, and temples in the different countries in the hope that they will be preserved. In addition to this, several thousand tickets of admission to the Crypt are being printed on metal to be handed down from father to son until the time for the opening of the Crypt, so that the memory of the Crypt will be kept alive.

NEW MOTION PICTURE APPARATUS

During the Conventions of the Society, symposiums on new motion picture apparatus are held in which various manufacturers of equipment describe and demonstrate their new products and developments. Some of this equipment is described in the following pages; the remainder will be published in subsequent issues of the Journal.

A NEW HIGH-QUALITY SOUND SYSTEM*

G. FRIEDL, JR., H. BARNETT, AND E. J. SHORTT**

During the 1938 Spring Meeting of the Society a group of Simplex 4-Star theater reproducing equipments were described.¹ These systems were designed to provide high-quality sound for small as well as for large theaters. A group of systems was necessary due to commercial considerations requiring the provision of most economical combinations consistent with theater sizes.

The design requirements, based on considerable research, experience, and consultation, were divided into four groups, as shown in Fig. 1.¹ The groups are: Sound Mechanism Equipment, Control Equipment, Power Amplifier Equipment, and Loud Speaker Equipment.

There are certain requirements shown here which may be considered as constants. For the sound mechanism they include the reproduction of 35-mm film at 90 feet per minute; adaptability to standard or push-pull reproduction; the requirement that normal speed be attained in 2 to 3 seconds; and that the total flutter be not greater than 0.15 per cent. The control equipment in each case will be required to offer the same number of change-overs with the standard 2000-ft reels, with a volume control at each machine. The power amplifier should have not more than 1 per cent total harmonic at 50 cycles, with noise level not exceeding -35 db. A two-way loud speaker system with multicellular horn may also be considered constants of design, each system having the same crossover frequency for economical reasons.

In view of the above requirements it was clearly indicated that for all systems the sound mechanism and the control equipment should be identical. The only variables of design were the power output of the amplifiers and, consequently, the power-handling capacity and coverage of the loud speakers.

Thus three systems were designed: The small, or *A* system, for houses up to 1000 seats; the medium, or *B* system, for houses up to 2000 seats; and the large,

* Presented at the 1939 Fall Meeting at New York, N. Y.; received November 4, 1939.

** International Projector Corp., New York, N. Y.

or *C* system, for houses up to 4000 seats. This manner of division was made in accordance with the recommendations of the Research Council of the Academy of Motion Picture Arts & Sciences.²

The main objective of insuring uniformly good reproduction of sound was attained in these systems through the careful consideration of design requirements, regardless of the size of theater.

Approximately 84 per cent of the theaters of the country have under 1000 seats, and of this total a very large percentage have less than 800 seats. For such a large group of houses, therefore, it seems justifiable that every effort should be

	Sound Mechanism Equipment	Control Equipment	Power Amplifier Equipment	Loud Speaker Equipment
Constants	35-Mm film 90 Ft/minute Standard, push-pull Dual channel 2-3 Sec pick-up 0.15% total flutter	Change-over 2000-Ft reels Volume control at each machine	1% Total harmonic at 50 cycles -35 Db noise level	Two-way system 400-Cycle cross- over Multicellular horn
Variable	None	None	Power	Power, Coverage
Small (1000 Seats) (84%)	Identical throughout ↓	Identical throughout ↓	<i>a</i> (15 watt)	<i>A</i> <i>B</i>
Medium (2000 Seats) (13%)	↓	↓	<i>2a</i> (30 watt)	<i>2A</i> <i>2B</i>
Large (4000 Seats) (3%)	↓	↓	<i>4a</i> (60 watt)	<i>2C</i> <i>4D</i>

FIG. 1. Analysis of design requirements.

made to provide a combination of equipment capable of good-quality reproduction without penalizing the exhibitor to the extent of purchasing equipment suitable for much larger theaters. With this in mind another system was designed especially for houses of less than 800 seats where the Simplex 4-Star *A* System can not be justified for economic reasons.

In analyzing the requirements for the new system we maintain that the same constants of design adhered to in previous equipments must be retained in order that there may be no sacrifice in the quality of reproduction. This immediately requires that no change be made in the sound mechanism as described above. Also, adequate control facilities must be retained since the duties to be performed remain the same. Thus the design variable is again the amount of power required.

It has been determined that an amplifier system capable of delivering 10 electrical watts affords adequate power for an 800-seat house and provides the margin of power required for the reproduction of the increased volume range of present-

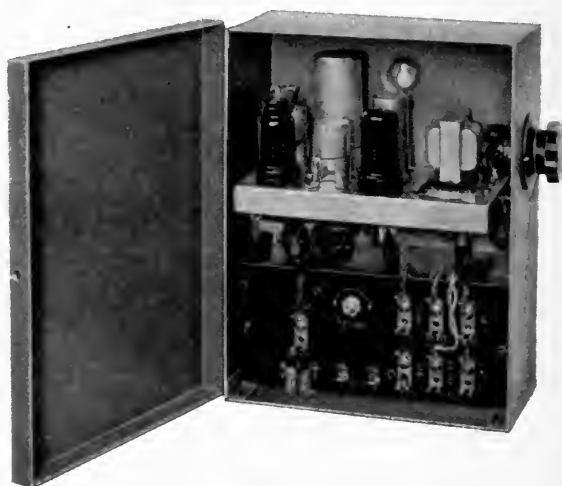

FIG. 2. Volume control amplifier.

day recordings. Since the cost of manufacturing a 10-watt amplifier is not a great deal less than that of a 15-watt unit, this alone will not result in an appreciable saving. Since we do not wish to sacrifice end-results, the economy must be

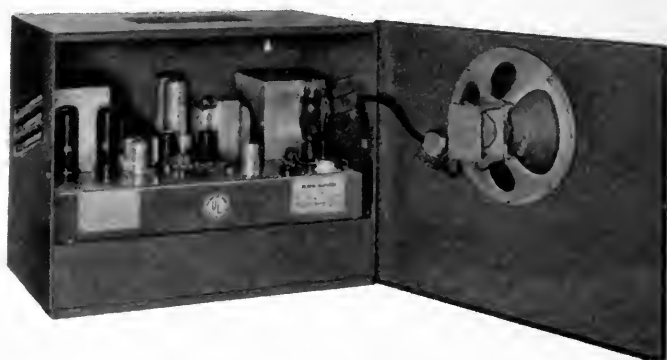

FIG. 3. Main amplifier in cabinet.

made in the elimination of certain facilities which are, of course, useful in operation and servicing but are not essential to the actual quality of reproduction.

First consideration of the facilities which might be sacrificed was given to the control, or front-wall, equipment. The use of high-impedance coupling between

the sound mechanism and preamplifier, having proved highly successful in previous designs, was maintained in the new system. A single front-wall unit is provided into which the high-impedance lines from the sound mechanism terminate. Fig. 2 shows a view of this amplifier in its cabinet. It is a two-stage resistance-coupled unit having a gain of approximately 45 db. All connections to the amplifier terminate on a bakelite terminal board located near the front of the cabinet. Screw connections are used here in order to facilitate removal of the amplifier chassis for service or replacement. A potentiometer balancing arrange-

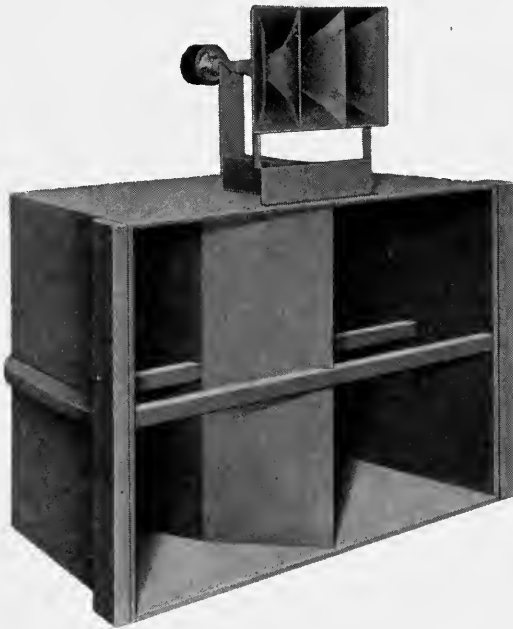

FIG. 4. Stage loud speaker equipment.

ment for the photoelectric cell voltage is arranged on the terminal board whereby the output of the two machines may be equalized. The volume control is located on the side of the cabinet to which an extension shaft is coupled providing a means of level adjustment at the operating side of either machine. A telephone jack is provided for the connection of non-synchronous attachments. Insertion of a plug into this jack disconnects the film input so that normal threading operations can be carried on without disturbances in the non-synchronous input.

Sound change-over is accomplished by means of exciter-lamp switching. A pair of interlocking switches is provided whereby the operating exciter-lamp voltage is transferred, and a standby voltage applied to the "OFF" exciter-lamp to prevent delay in change-over time.

Fig. 3 shows a view of the main amplifier cabinet with the amplifier installed. Resistance coupling is used between this unit and the front-wall amplifier since, as in former systems, we have shunned the use of audio transformers in order to avoid hum pick-up. The power amplifier is capable of delivering 10 watts of audio power with less than 1 per cent total harmonic distortion. Adjustable inverse feedback is employed for the purpose of providing equalization of the speech circuit in addition to its normal functions of noise suppression and reduction of distortion. Adjustment of the feedback circuit can be readily made by means of straps on the terminal board, which is conveniently located on the front of the amplifier chassis.

A separate monitor circuit is built into the amplifier, bridging across the output line, consuming practically no power and providing a gain of about 15 db above the stage line. The monitor unit and its control are mounted on the door

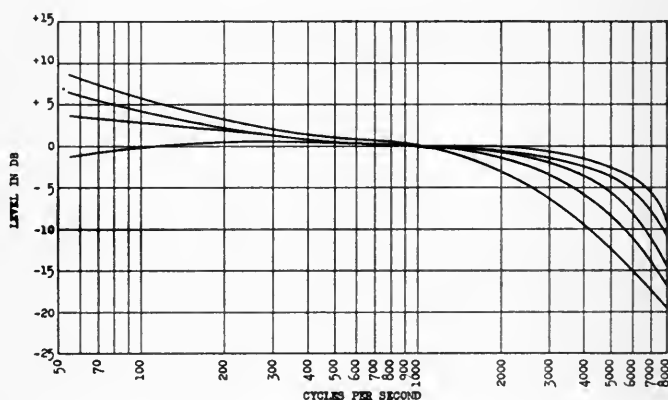

FIG. 5. Electrical characteristics of Simplex Type *E* system.

of the cabinet, and connected to the amplifier by means of a polarized socket on the amplifier chassis.

The amplifier chassis can be drawn forward and tilted upward at approximately a 45-degree angle in order to facilitate servicing. All connections to the amplifier are of the screw type, located on the terminal board back of the protecting plate, permitting easy removal of the unit to facilitate service and replacement.

The exciter-lamps are operated on alternating current. A high-wattage lamp was selected in order to reduce the 120-cycle modulation, since it is known that this factor is dependent on the heat storage or rate of cooling of the lamp filament. In addition, a 120-cycle tuned circuit is inserted in the front-wall amplifier which serves to attenuate the hum level resulting from a-c lamp operation.

Fig. 4 shows the two-way loud speaker equipment designed for use with this new system. The high-frequency loud speaker assembly consists of a multi-cellular, exponential horn for wide-angle distribution, insuring uniform balance

throughout its frequency range. The high-frequency unit is a permanent-magnet dynamic type, employing a metallic diaphragm. The low-frequency speaker is a 15-inch permanent-magnet dynamic type enclosed within a folded horn of solid and sturdy wood construction. Both the low- and high-frequency units are capable of handling more than 15 watts of electrical power, thus giving ample margin and dependable service. The dividing network is located back stage with the speakers. The overall gain of the system is about 100 db, which is sufficient for both film reproduction and the operation of non-synchronous equipment.

The electrical characteristic may be adjusted over a wide range at either the low or high frequencies. Fig. 5 indicates the range of equalization available. The recommendations of the Academy of Motion Picture Arts and Sciences, as well as the variations in acoustical conditions encountered in the field, have been regarded in the selection of these response characteristics.

The simplicity of installation of this equipment can be seen in Fig. 6. The single preamplifier, the exciter-lamp supply, and the two change-over switches are located on the front wall. The main amplifier cabinet, including the monitor, is located on the side or rear wall. Conduit requirements are reduced to a minimum, and the space required should not tax even the smallest projection room.

No sacrifice has been made in the quality of the component parts of this system, but rather every effort has been made to obtain the most reliable material available, servicing and replacement operations have been simplified and standard vacuum tubes, which are universally obtainable and inexpensive, are used throughout. Thus an economical sound equipment has been developed for the small houses affording a quality of sound reproduction comparable to that found in the larger theaters.

(Two recordings were used for the demonstration, one being Raymond Paiges' Dark Eyes from Hollywood Hotel released by Warner Bros. the latter part of 1937, recorded on standard variable-area track. The other was from Metro-Goldwyn-Mayer's Babes in Arms recorded on standard variable-density track. We wish to express our appreciation to Major N. Levinson, of Warner Bros., and to Mr. Lester Isaac, of Loew's Theatres, Inc., who furnished the films.)

REFERENCES

¹ FRIEDL, G., JR.: "A New Sound System," *J. Soc. Mot. Pict. Eng.*, **XXXI** (Nov., 1938), p. 511.

² HILLIARD, J. K.: "Projects of the Committee on Standardization of Theater Sound Projection Equipment Characteristics of the Academy of Motion Picture Arts & Sciences," *J. Soc. Mot. Pict. Eng.*, **XXX** (Jan., 1938), p. 81; *Bull. Academy of Motion Picture Arts & Sciences* (June 8, 1937).

DISCUSSION

MR. CRABTREE: This demonstration proves that we can do a lot more than is being done at present with the film emulsions that are now available. I had previously heard this film in a theater and the sound was terrible. I think that if we could always hear sound of the same high quality as we have just heard, we would be quite satisfied.

MR. MORGAN: What high-frequency unit do you use in the system?

MR. BARNETT: A permanent-magnet dynamic unit, metallic diaphragm. The horn is multicellular—three cells.

MR. READ: The speaker mentioned that the lamp was operated on a-c and that a 120-cycle filter was used. How great was the attenuation?

MR. BARNETT: The 120-cycle attenuation is about 10 db.

SIMPLEX DOUBLE-FILM ATTACHMENT*

W. BORBERG AND E. PIRNER**

The Simplex double-film attachment (Fig. 1) described herein is designed for use with the Simplex 4-Star sound system where separate picture and sound prints are to be run for reviewing purposes in studios or for showing pre-release prints in theaters.

The equipment consists primarily of a large magazine, in which are mounted two take-up shafts and one feed-shaft to accommodate three reels. A film channel, connecting the projector mechanism directly to this magazine, detours the film around the sound mechanism. This avoids congestion, facilitates threading, and permits easy observation during operation (Fig. 2).

The picture print is in the upper magazine on spindle *A*. It is threaded through the projector in the normal manner, but leaves the projector after passing over the lower holdback sprocket and goes through the film-channel over a pair of guide-rollers to the take-up reel, which is mounted on spindle *C*.

The sound-print feed-reel is placed on spindle *D* in the lower right-hand corner of the magazine. The film runs over a pair of guide-rollers to a special gear-driven sprocket which feeds it into the sound mechanism scanner. The film passes through the sound mechanism in the usual manner and then to the take-up reel, which is mounted on spindle *B*. There is ample clearance in the lower magazine to permit the use of three 1000-ft reels with 5-inch hubs.

For ordinary sound and picture projection, where the picture and sound are on the same print, the film is threaded through the projector and sound mechanism in the same manner as in standard projection equipment. In this case (Fig. 3) standard 2000-ft reels with 5-inch hubs can be used in the upper and lower magazines. With a 2000-ft reel in the take-up magazine it is necessary only to shift the guide-roller *a* in the lower magazine. The magazine door is double-hinged, and for single-film operation only one-half of the door need be opened. The clearance, when 2000-ft reels with 5-inch hubs are used, is similar to that in the standard 18-inch magazine.

Special consideration has been given to the importance of insuring smooth film passage through the projector, sound mechanism, and double-film attachment.

* Presented at the 1939 Fall Meeting at New York, N. Y.; received October 28, 1939.

** International Projector Corp., New York, N. Y.

The guide-rollers are equipped with ball-bearings, and have high flanges on both sides. All parts coming into contact with the film are sufficiently undercut to prevent damage to the sound-track and picture area. An extra sprocket is provided to feed the sound-print from the lower magazine into the sound mechanism. This makes threading easy, avoids sharp bends of the film, and thus reduces the



FIG. 1. Simplex double-film attachment.

possibility of patches coming apart. This sprocket is located in the upper part of the film-channel, and is directly geared to the sound mechanism projector drive-gear.

The entire feed-sprocket assembly is mounted on a hinged bracket which engages the feed-sprocket gear with the projector drive-gear, and permits adjustment for proper mesh of teeth without requiring shims (Fig. 4). When combined sound and picture prints are projected, this bracket can be raised to disengage the two gears.

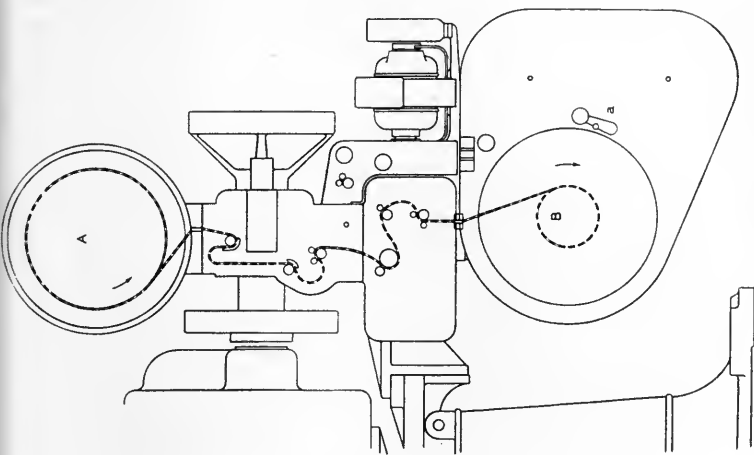

FIG. 3. Standard 2000-ft reels for ordinary sound and picture projection.

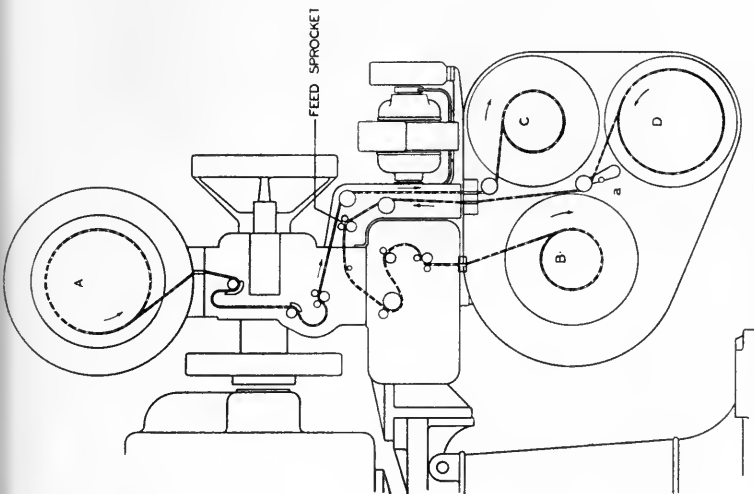

FIG. 2. Film path through projector.

Important features of the Simplex double-film attachment are simplicity of adaptation to the projection equipment, elimination of fitting and adjustments on the job, and the elimination of shims for alignment purposes. The double-film attachment is designed for interchangeable use with Simplex *E-7* or Super-Sim-

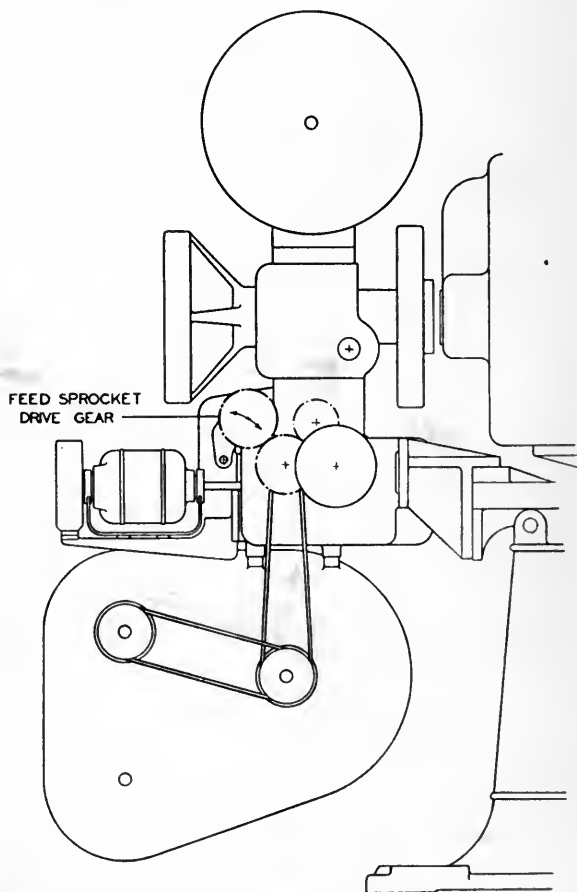

FIG. 4. Showing mounting of feed-sprocket assembly.

plex mechanisms. With this attachment, when used on installations with Super-Simplex or Simplex *SI* pedestals, downward projection angles to 30 degrees and upward projection angles to 3 degrees can be accommodated.

The overall length of projector, sound mechanism, and double-film attachment is increased by only $1\frac{1}{2}$ inches over that of the standard Simplex equipment with 18-inch magazines.

DISCUSSION

MR. RICHARDSON: What is the idea of projecting picture and sound-film separately with one projector?

MR. PIRNER: For preview purposes. After the preview all the changes necessary are made, and then the sound and picture are combined on one print.

DR. GOLDSMITH: Is this attachment adaptable to the standard projector?

MR. PIRNER: Yes.

MR. BRADY: What would be the effect of running two prints exactly alike, simultaneously and in perfect synchronism?

MR. FRIEDL: That is a very interesting question, although it is irrelevant to the paper. I believe what you are asking is the effect of superimposing identical prints, in the hope of obtaining stereoscopic effects, and, perhaps, stereophonic sound. Several times at this meeting mention has been made of three-dimensional pictures as being "on the horizon," and as representing a challenge to our technicians. This attachment, however, is not intended to achieve that result. This is only for projecting a picture film and a sound-film simultaneously, for the purpose of previewing. One of its major uses is in preview theaters, particularly in Hollywood. Before going to the expense of a final editing the producers want to try the picture on the public, and later edit it according to the reaction of the public and the comments of the studio executives. Usually the one film has the picture only and the other film the sound-track only. Two complete picture and sound-track films could be projected, but you would get only the picture off one and only the sound-track off the other.

MR. CRABTREE: In the case of a grainy picture, what would be the effect of simultaneously projecting several identical images?

DR. GOLDSMITH: It would be interesting to know whether graininess of the prints would be reduced by superimposed projection of several identical images. Theoretically, and on a basis of statistical averages, this process would reduce graininess. But since graininess in average focused pictures is a relatively mild fault, it would hardly seem worth while to use multiple projection to reduce it.

A NON-INTERMITTENT MOTION PICTURE PROJECTOR*

F. EHRENHAFT AND F. G. BACK**

The problem of non-intermittent film projection was treated in detail by Tuttle and Reid¹ in 1932. Since then a considerable number of various devices for such a projection method has been developed.

Our improvements are based upon the development of a projector designed in such manner that optical compensation is effected by means of a rotating glass prism placed between the film and the projection lens. This projector is very

* Presented at the 1939 Fall Meeting at New York; received October 10, 1939.

** New York, N. Y.

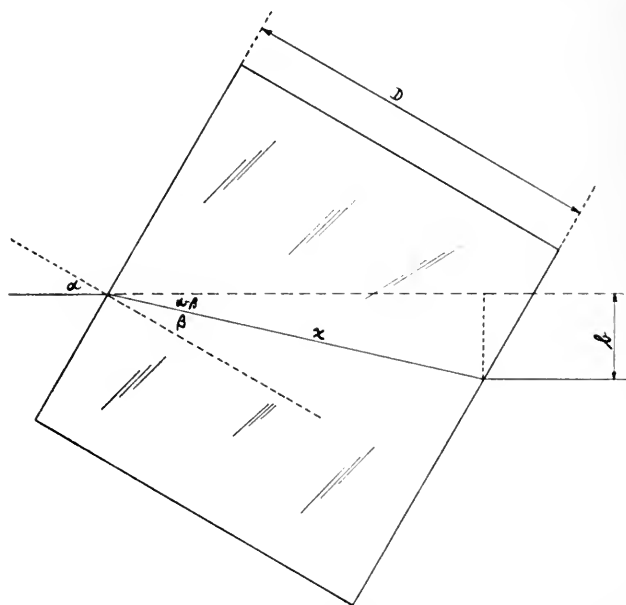

FIG. 1. Plane parallel glass plate penetrated by a light-ray.

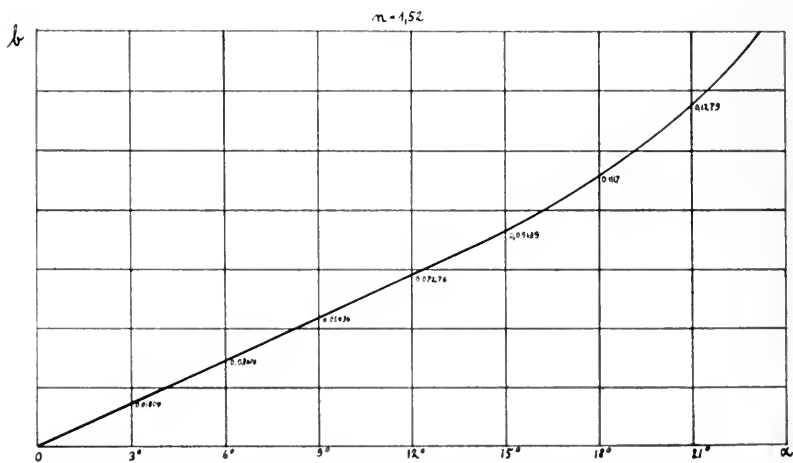

FIG. 2. The relation between the displacement and the angle of incidence.

simple and reliable in use, and is especially suited for synchronous sound reproduction. Its perfection and efficiency depend, of course, upon eliminating the optical errors caused by the glass prism or at least upon reducing such errors to a degree where they will not sensibly influence the projection.

Basic optical laws prescribe the dimensions of the rotating prism as well as its optical placement with respect to the mechanism. The latter in turn depends upon the size of the film frame and upon the glass material of the prism.

In Fig. 1 is shown a plane parallel glass plate penetrated by a light-ray. This light-ray enters the plate at the angle of incidence α , passes through the plate at the angle of refraction β , and emerges from the plate parallel to the incident ray,

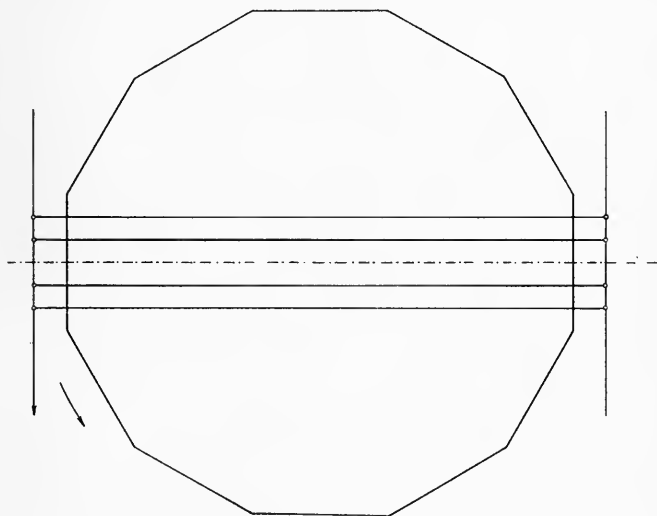

FIG. 3. Position of the rotating prism, two faces vertical to the optical axis.

but displaced by a distance b . As Fig. 1 shows all necessary angular relations, the vertical displacement b can be calculated.

Letting z equal the length of the path of the light-beam through the glass, and n the index of refraction:

$$\begin{aligned} b &= z \sin (\alpha - \beta) \\ D &= z \cos \beta \end{aligned}$$

$$b = \frac{D \sin (\alpha - \beta)}{\cos \beta} \text{ or } D = \frac{b \cos \beta}{\sin (\alpha - \beta)}$$

The vertical displacement b is a function of the angle of incidence α , the index of refraction n , and the thickness of the plate. Fig. 2 is a plot of this function for a value of $n = 1.52$, a value of unity having been assumed for the thickness D .

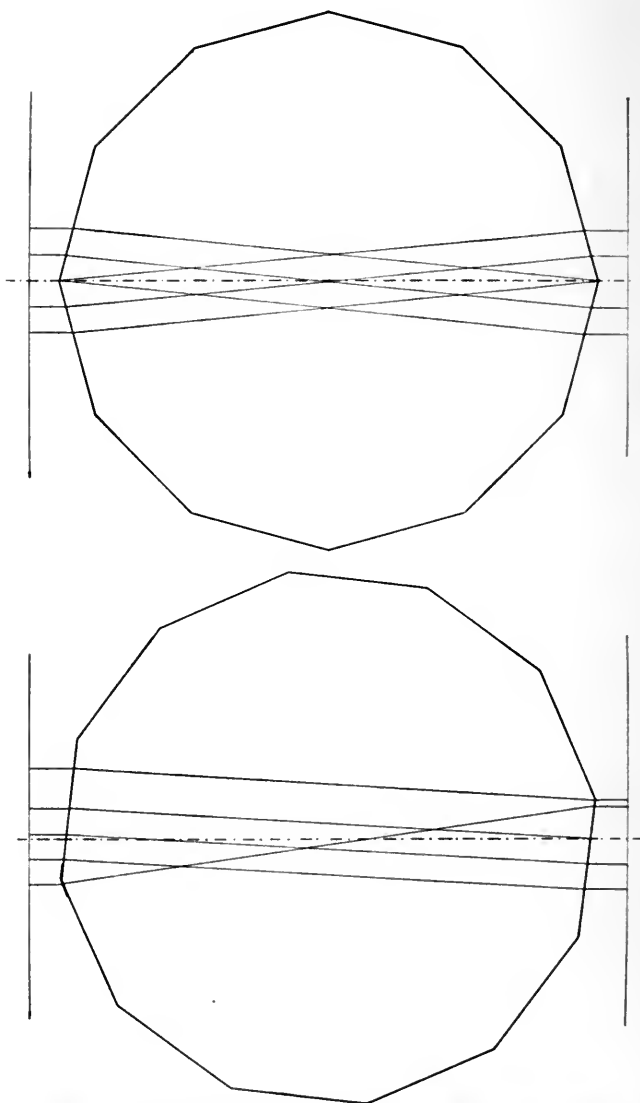

FIG. 4. (*Upper*) Position of the rotating prism, two edges on the optical axis.

FIG. 5. (*Lower*) Position of the rotating prism, two edges below the optical axis.

The function is linear up to the angle of 15 degrees. Therefore, a uniformly rotating plane parallel plate causes a uniform displacement of the light-ray so long as the tilting angle of 15° is not exceeded.

Applying this condition to a rotating glass prism, at the instant the prism has been rotated 15 degrees, the succeeding image must be projected; hence the necessary number of prism faces can be calculated:

$$\frac{360}{2 \times 15} = 12$$

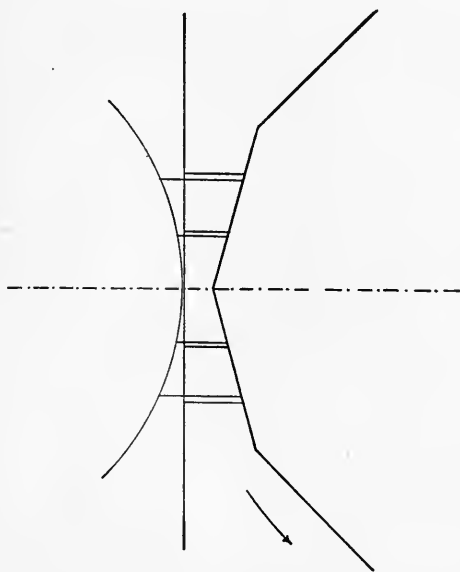

FIG. 6. The curved gate of the film.

A polygonal prism of 12 faces, therefore, allows a linear displacement. Now the necessary thickness of the prism can be calculated. Rotation of the prism by 15 degrees corresponds to a displacement of half an image, which is 3.81 mm in the case of 16-mm film. In Fig. 2, D was assumed equal to unity; hence, if B is height of the half-frame on the film and the value of b is taken as 0.0918, then

$$\frac{B}{b} = \frac{D}{1}$$

or $D = 41.5$ mm.

In the following discussion of the optical conditions the influence of the lens upon the light-rays has not been considered. The differences caused by the fact that the lens does not give strictly parallel rays are relatively so small that they may be neglected if a lens with long focal length is used.

In the projection of film frames two extreme positions of the prism must be considered. The position shown in Fig. 3 does not result in any outstanding effect. In Fig. 4 two edges of the prism are located on the optical axis. The image seen looking through the prism, hereafter termed *visible image*, is formed by the halves of two succeeding film frames.

The upper half of the visible image is formed by the upper part of the lower frame while the lower half is formed by the lower part of the upper frame. In this position of the prism the extreme angle of 15 degrees is exactly achieved but not exceeded, and the visible image is free from astigmatism.

Conditions become more unfavorable with further tilting of the prism (Fig. 5). The visible image is composed of a major portion of the upper film frame and a



FIG. 7. The complete projector.

minor portion of the lower film frame. The position of the prism faces now below the optical axis corresponds here with the unfavorable unlinear section of the curve of Fig. 2. The larger part of the visible image has good definition, since it corresponds to the linear section of the curve; the other part, formed by the lower frame, shows astigmatic distortions which increase with further tilting of the prism until the upper frame enters into the position shown in Fig. 3.

The effect of exceeding the 15-degree angle appears as varying astigmatism. To reduce this effect it would be useful to utilize a prism with 24, at least 16, faces; but the dimensions would be larger.

During the passage of the film frame from one position to the next, two positions exist without defects caused by tilting of the prism; namely, the positions of Figs. 3 and 4. Immediately before reaching the position of Fig. 3 the upper part of the visible image shows astigmatic distortion. These errors can be reduced by black-

ing out the edges of the prism in order to render them inactive when in the unfavorable position of Fig. 5.

Fig. 5 shows another phenomenon: The peripheral speed of the rotating prism is higher than the speed of the film. By using glass having a higher index of refraction, the diameter of the prism would be reduced, and hence its peripheral speed. A certain choice of index of refraction would nearly equalize the peripheral speed of the prism and the speed of the film and thereby minimize the defects caused by the different speeds, but unfortunately, glass of such an index can not be utilized for our purposes.

The shrinking of film has a marked effect upon the distortion, and the designer must consider seriously this important factor. The reduction of the length of the film can be compensated by an adjustable roller in a very simple manner, but in a

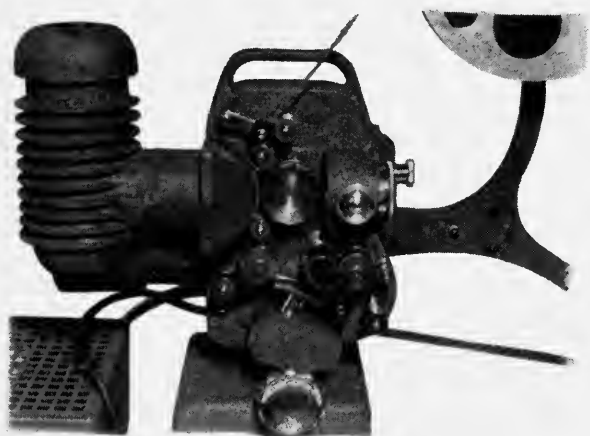

FIG. 8. Close-up of projector.

projector where the size of the film frame influences the entire optical arrangement, particularly dimensions of the prism, such compensation is not sufficient.

The frame of the shrunken film has a smaller vertical dimension than the figure used for the calculation of the prism and serious confusion of the projected image results. The use of an adjustable curved gate (Fig. 6) allows satisfactory compensation, the curve corresponding to the maximum size of frame and the prism being calculated for this size. Altering the curve in accordance with the amount of the shrinkage, then, will compensate for differences in the vertical dimension.

Guiding the film in a curve causes mislocation of the frame with respect to the optical system and incorrect definition is the consequence. This can be avoided by using lenses of greater depth of field. A slit limiting the vertical aperture of the lens used as stop for the projection lens achieves this condition and simultaneously reduces the astigmatic errors very materially.

A further advantage of using this slit is the following: Projecting a film upon a screen one sees a central image on the optical axis and secondary images above

and below caused by the other prism faces out of action. These disturbing secondary images must be screened out. The necessary diaphragm should be as distant as possible from the projection lenses. The smaller the vertical aperture of the lens the more effective is the diaphragm. The reduction of light-intensity as the consequence of using the diaphragms mentioned above may be tolerated as no rotating shutter is utilized in the projector.

Furthermore we must consider the fact that standard projection lenses are corrected for light-rays passing in air. It is necessary to correct the optical system for spherical aberration considering the glass prism in the beam of light.

The steadiness of the film frames in relation to the prism faces has been assumed to be perfect. Any unsteadiness of this sort causes distortion on the screen. To prevent misalignment of the prism faces with respect to the film frames during the rotation of the prism, the prism is driven by the film itself, in such a manner that the edges of the prism are located in the optical axis as well as on the dividing line between the film frames.

The chromatic errors caused by the fact that the indices for different wavelengths are different are insignificant. The projection of a still picture renders an image showing serious distortion but during the rotation of the prism the images of the complementary light-rays are superimposed upon each other throughout the symmetrical positions of the prism.

To reduce loss of light the condenser and the projection lamp are arranged to concentrate the light-rays in vertical direction. Finally it is necessary to prevent mirages caused by total reflection of the prism faces out of action. The concentration of the light-beam, mentioned above, and the arrangement of the diaphragms may achieve this result.

A projector designed according to the above-described optical arrangement shown in Figs. 7 and 8 gives satisfactory projection and is particularly suitable for sound scoring as the absence of the intermittent movement permits inherently continuous motion of the sound carrier.

The authors are at the present time designing a steel tape recorder in collaboration with Acoustic Consultants, Inc., to be incorporated in the projector. In practice, original records will be made an integral part of the photographic record and used for reproduction as sound-on-film. The original steel tape sound negative may be kept or the record obliterated and the tape used again for original sound recording.

REFERENCE

¹ TUTTLE, F., AND REID, C. D.: "The Problem of Motion Picture Projection from Continuously Moving Film," *J. Opt. Soc. Amer.*, **22** (Feb., 1932), p. 39; *J. Soc. Mot. Pict. Eng.*, **XX** (Jan., 1933), p. 3.

DISCUSSION

MR. OFFENHAUSER: At what speed was the film running? It appears to be faster than normal.

MR. EHRENHAFT: Sixty cycles. The machine was designed for 50 cycles.

MR. OFFENHAUSER: Have you had an opportunity to make studies of comparative flicker of this type of arrangement *vs.* that of a conventional mechanism?

MR. BACK: The prism has 12 faces, and it has been necessary to screen the edges, otherwise the astigmatism would be considerable. With a prism of 16 faces it is not necessary to screen the edges; there is then no flicker at all.

MR. TOWNSLEY: Is the compensation for shrinkage automatic? If in a reel there are two pieces of film of different shrinkages, is there compensation without manual adjustment?

MR. BACK: Not in this projector. The gate must be adjustable to compensate for shrinkage while the film is running.

MR. CRABTREE: What are the fundamental advantages, compared with our present intermittent type of projector. Both C. Francis Jenkins and A. J. Holman have demonstrated optical intermittents, but from a practical standpoint they do not seem to have shown any outstanding advantages.

MR. BACK: The sound reproduction is much simpler when there is no intermittency in the film movement. The film runs at constant speed, which is much better for the perforations and the emulsion.

MR. EHRENHAFT: Another advantage is that the film indirectly guides the prism, so there is no relative movement between the film and the prism.

MR. CRABTREE: It has always been claimed that the advantage of the non-intermittent projector was that it prolonged the life of the film. That is of no real value at the present time. Film is not discarded because of torn perforations but because of scratches. In other words, the film is strong enough to withstand the intermittent.

Optical intermittents have many disadvantages, including the difficulty of keeping the optical system free from dust and dirt, and there is the matter of expense.

MR. BACK: The expense is less than with other projectors because the sound system is much simpler.

MR. PALMER: We had a number of continuous projectors operating at the World's Fair this summer, and films have run through them as many as 1200 times without any damage to the perforations. The films have to be replaced because they become scratched, not because the perforations are damaged. The scratching is not usually caused by the projector gate, but by winding the film in a continuous roll; the friction of one layer against the other causes the scratches.

MR. HOLSLAG: Is it necessary to illuminate two full frames?

MR. BACK: No; only one frame and about one-eighth of the next.

MR. CRABTREE: I noticed a rather bad flicker at the top edge of the picture.

MR. BACK: That was caused by blacking out the edges of the prism. The prism is a 12-faced prism; when we use a 16-face prism it is not necessary to black out the edges, and then we have no flicker at all.

CURRENT LITERATURE OF INTEREST TO THE MOTION PICTURE ENGINEER

The editors present for convenient reference a list of articles dealing with subjects cognate to motion picture engineering published in a number of selected journals. Photostatic copies may be obtained from the Library of Congress, Washington, D. C., or from the New York Public Library, New York, N. Y. Micro copies of articles in magazines that are available may be obtained from the bibliofilm Service, Department of Agriculture, Washington, D. C.

American Cinematographer

20 (Dec., 1939), No. 12

- Testing New Weston Meter (pp. 533-534, 538) T. SPARKUHL
Use of Fine Grain Positive Emulsions for Variable Density J. K. HILLIARD
Film Recording (pp. 535-537, 564) W. STULL
M-G-M Builds Unique Camera Boom (pp. 539-540, 572) O. I. SPRUNGMAN
Reeves Builds 16-35-Mm. Developer (pp. 541, 566)
Reproduction of Film Exposed 40 Years Ago (p. 546)
Smoothing Scene Transitions (pp. 551-554)

British Journal of Photography

86 (Nov. 3, 1939), No. 4148

- Progress in Colour (pp. 659-660)
A Note on the Permanence of Agfacolor (pp. 663-664)
86 (Nov. 10, 1939), No. 4149
Progress in Colour (pp. 674-676)
86 (Nov. 17, 1939), No. 4150
Progress in Colour (pp. 685-686)

Communications

19 (Nov., 1939), No. 11

- Syncrosound System (pp. 12-13) R. C. POWELL
Television Economics. Pt. X (pp. 23-25) A. N. GOLDSMITH

Electronics and Television and Short-Wave World

(Nov., 1939)

- American Methods of Film Transmission (pp. 630-633) E. W. ENGSTROM,
G. L. MEERS, AND
A. V. BEDFORD

Kinotechnik

21 (Oct., 1939), No. 10

- Die geräuscharme Atelierkamera der Askania-Werke
A.-G., Berlin-Friedenau. (Noiseless Askania-Werke
Studio-Camera) (pp. 235-237) P. HEINISCH

Beziehungen zwischen Bild- und Tonsensitometrie.
(Relation between Image and Sound Sensitometry)
(pp. 237-241)

A. NARATH

Das Mehrfachkopieren von Kinofilmen. (Multiple Prints
from Motion Picture Film) (pp. 241-243)

O. BENDER

Philips Technical Review

4 (Oct., 1939), No. 10

An Acoustic Spectroscope (pp. 290-291)

J. F. SCHOUTEN

The Efficiency of Loud Speakers (pp. 301-307)

J. DE BOER

Photo Technique

1 (Dec., 1939), No. 7

A Flexible Time Lapse Outfit (pp. 28-31)

W. W. EATON

BOOK REVIEW

The History of Photography; Its Relation to Civilization and Practice; Dr. Erich Stenger; translation and footnotes by Edward Epstein (1939), *Mack Printing Co.*, Easton, Pa.

Here is a book on the history of photography written by the man who, after Professor Eder, is the most competent in Germany to write upon such a subject. The translation into English, faithfully carried out, is by Mr. Edward Epstein of New York, who has done more than anyone in recent years to make photographic history available to the English-speaking public. Mr. Epstein has given much of his time and money to the preparation of translations of the most important French and German works on the subject.

The present book is interesting from two points of view: (1) the early history of photography and the earlier stages in the development of photographic processes and their applications are dealt with in great detail, and will be a valuable source of reference; (2) the book represents a picture of the present German viewpoint of the subject. Mr. Epstein points out in his preface that it is difficult to write history objectively, and that any criticism that might be raised as to the preference of the author for his Fatherland might apply equally to history books written in other countries. A presumably "controlled" book on photographic history may in itself, however, be an interesting historical document. We must admire Mr. Epstein for arranging for the publication himself when the international situation led his original publisher to disavow any sponsorship of the book.

There is perhaps a tendency to place too much emphasis on information as to the first people who started to do things which later developed into something worth while, and not enough information about what they led to. However, there are many who will be interested in ready references to the early historical material, and to them the book will be valuable.

Mr. Epstein has added many footnotes, correcting certain misstatements in the text, and amplifying some of the material.

W. CLARK

1940 SPRING CONVENTION

SOCIETY OF MOTION PICTURE ENGINEERS

CHALFONTE-HADDON HALL, ATLANTIC CITY, NEW JERSEY
APRIL 22-25, INCLUSIVE

Officers and Committees in Charge

E. A. WILLIFORD, *President*
S. K. WOLF, *Past-President*
W. C. KUNZMANN, *Convention Vice-President*
J. I. CRABTREE, *Editorial Vice-President*
S. HARRIS, *Chairman, Papers Committee*
J. HABER, *Chairman, Publicity Committee*
H. GRIFFIN, *Chairman, Convention Projection*
E. R. GEIB, *Chairman, Membership Committee*
H. BLUMBERG, *Chairman, Local Arrangements*

Reception and Local Arrangements

HARRY BLUMBERG, *Chairman*

M. C. BATSEL	E. O. WILSCHKE	E. W. KELLOGG
A. B. FREEMAN	W. J. CHARLES	H. WALTERS
C. A. SEUBERT	M. LEWIS	F. B. EVANS
C. W. TREEN	W. CONNER	L. RATENER

Registration and Information

W. C. KUNZMANN, *Chairman*
J. FRANK, JR.

E. R. GEIB

F. HOHMEISTER

Hotel and Transportation

E. O. WILSCHKE, *Chairman*

S. ABRAMS	C. A. SEUBERT	J. DEFRENES
C. COHEN	B. BLUMBERG	H. J. MAIRE
F. J. BETTELLI	C. PRESGRAVE	G. L. DIMMICK

Publicity

J. HABER, *Chairman*

S. HARRIS	P. A. MCGUIRE
J. J. FINN	F. H. RICHARDSON

Convention Projection

H. GRIFFIN, *Chairman*

M. C. BATSEL	H. BLUMBERG	E. O. WILSCHKE
M. LEWIS	H. WALTERS	W. J. CHARLES
C. W. TREEN	F. HOHMEISTER	A. B. FREEMAN

Officers and Members Projectionists Local 310, IATSE

Banquet and DanceM. C. BATSEL, *Chairman*

H. BLUMBERG

E. W. KELLOGG

B. BLUMBERG

W. J. CHARLES

H. WALTERS

A. B. FREEMAN

E. O. WILSCHKE

O. F. NEU

C. W. TREEN

Ladies' Reception CommitteeMRS. O. F. NEU, *Hostess**assisted by*

MRS. M. C. BATSEL

MRS. E. O. WILSCHKE

MRS. H. BLUMBERG

MRS. C. W. TREEN

MRS. A. B. FREEMAN

MRS. B. BLUMBERG

MISS L. A. MOYER, *Social Director*, Chalfonte-Haddon Hall**Headquarters**

Headquarters.—The headquarters of the Convention will be the Chalfonte-Haddon Hall, where excellent accommodations have been assured, and a reception suite will be provided for the Ladies' Committee.

Reservations.—Early in March room reservation cards will be mailed to members of the Society. These cards should be returned as promptly as possible in order to be assured of satisfactory accommodations.

Hotel Rates.—Special rates have been guaranteed by the Chalfonte-Haddon Hall to SMPE delegates and their guests. These rates, European plan, will be as follows:

	<i>Four Lower Floors</i>	<i>Ocean View</i>	<i>Ocean Front</i>
Room for one person	\$ 3.50	\$ 4.00	\$ 5.00
Room for two persons	6.00	7.00	8.00
Parlor Suite, for one	10.00	12.00	14.00
Parlor Suite, for two	14.00	16.00	18.00

(All bathrooms at Haddon Hall have hot and cold running fresh and salt water)

If American plan rates are desired the hotel room clerk should be advised accordingly when registering. An additional charge of \$3 per day per person will be added to the above-listed European rates for three daily meals, American plan. Members and guests registering at the hotel on the American plan will pay only \$3 for the SMPE banquet scheduled at Haddon Hall on Wednesday evening, April 24th. If registered on the American plan, the clerk at registration headquarters should be advised accordingly when procuring your banquet tickets.

Parking.—Parking accommodations will be available to those who motor to the Convention at the Chalfonte-Haddon Hall garage, at the rate of 50¢ for day parking or \$1.25 for twenty-four hours. These rates include pick-up and delivery of car.

Registration.—The registration and information headquarters will be located at the entrance of the *Viking Room* on the ballroom floor where the technical and business sessions will be held. All members and guests attending the Convention

are expected to register and receive their badges and identification cards required for admission to all the sessions of the Convention, as well as to several motion picture theaters in the vicinity of the Hotel.

Technical Sessions

The technical sessions of the Convention will be held in the *Viking Room* of the Hotel. The Papers Committee plans to have a very attractive program on papers and presentations, the details of which will be published in a later issue of the JOURNAL.

Luncheon and Banquet

The usual informal get-together luncheon will be held in the *Benjamin West Room* of Haddon Hall on Monday, April 22nd, at 12:30 p.m. The forty-sixth Semi-Annual Banquet and Dance of the Society will occur on the evening of Wednesday, April 24th, in the *Rutland Room* of Haddon Hall—an evening of dancing and entertainment for members and guests.

Ladies' Program

A specially attractive program for the ladies attending the Convention is being arranged by Mrs. O. F. Neu, *Hostess*, and the Ladies' Committee. A suite will be provided in the Hotel where the ladies will register and meet for the various events upon their program. Further details will be published in a succeeding issue of the JOURNAL.

Entertainment

At the time of registering, passes will be issued to the delegates of the Convention admitting them to several motion picture theaters in the vicinity of the Hotel. The names of the theaters will be announced later.

Atlantic City's boardwalk along the beach offers a great variety of interests, including many attractive shops and places of entertainment.

W. C. KUNZMANN,
Convention Vice-President

SOCIETY ANNOUNCEMENTS

ATLANTIC COAST SECTION

At a meeting held on January 10th at the Engineering Societies Building, New York, a paper was presented by J. A. Maurer of the Berndt-Maurer Corporation, on the subject of "Motion Picture Production in 16-Mm."

Recent improvements in film stocks, apparatus, and laboratory technics have greatly improved the print quality attainable when photographing pictures directly on 16-mm film. With the availability of high-quality 16-mm sound-recording equipment, these developments have led to considerable activity in professional direct 16-mm production.

Mr. Maurer broadly surveyed the equipment, materials, and services existing in the 16-mm field, appraised the results attained, and forecast what may be expected from the application of still newer materials and technics not now in general use.

Results with currently available materials were demonstrated, including the reproduction of examples of sound and picture duplicates on Kodachrome, a field that has recently assumed considerable commercial importance.

The meeting was attended by approximately 200 persons and closed with an extended discussion of the paper.

MID-WEST SECTION

At a meeting held on December 9th at the meeting rooms of the Western Society of Engineers, Chicago, a paper by Mr. M. Wenzel of the Wenzel Company, Chicago, on the subject of "New Developments in Theater Motion Picture and Sound Projectors" was read by Mr. J. S. Scanlon of the same company. The paper dealt with recent developments in the design of theater equipment and the results attained therewith. The meeting was well attended and a lively discussion followed the presentation.

PACIFIC COAST SECTION

On December 11th, at the Bell & Howell Building, Hollywood, the subject of "Color—1939" was discussed by L. E. Clark.

In addition, an exhibition was given on Cinecolor 16-Mm Reduction Prints accompanied by an inspection of the Cinecolor reduction process, by A. M. Gundelfinger.

JOURNAL

OF THE SOCIETY OF

MOTION PICTURE ENGINEERS

Volume XXXIV

March, 1940

CONTENTS

	<i>Page</i>
Large Size Non-Rotating High-Intensity Carbons and Their Application to Motion Picture Projection.....	
D. B. JOY, W. W. LOZIER, AND R. W. SIMON	241
The Development and Practical Application of the Triple-Head Background Projector.....	
B. HASKIN	252
Motion Picture Auditorium Lighting.....	
B. SCHLANGER	259
Automatic Slide Projectors for the New York World's Fair....	
F. TUTTLE	265
The Vocoder—Electrical Re-Creation of Speech.....	
H. DUDLEY	272
The Objective Measurement of the Graininess of Photographic Emulsions.....	
A. GOETZ, W. O. GOULD, AND A. DEMBER	279
Regulations of the National Board of Fire Underwriters for the Storage and Handling of Nitrocellulose Motion Picture Film	311
New Motion Picture Apparatus	
A Flexible Time-Lapse Outfit.....	
A. B. FULLER AND W. W. EATON	334
Film Splicer for Developing Machines.....	
J. G. CAPSTAFF AND J. S. BEGGS	339
Current Literature.....	342
1940 Spring Convention at Atlantic City, N. J., April 22nd to 25th.....	344
Society Announcements.....	347

JOURNAL OF THE SOCIETY OF MOTION PICTURE ENGINEERS

SYLVAN HARRIS, EDITOR

Board of Editors

J. I. CRABTREE, *Chairman*

A. N. GOLDSMITH

A. C. HARDY

T. E. SHEA

J. G. FRAYNE

L. A. JONES

G. E. MATTHEWS

E. W. KELLOGG

Subscription to non-members, \$8.00 per annum; to members, \$5.00 per annum, included in their annual membership dues; single copies, \$1.00. A discount on subscription or single copies of 15 per cent is allowed to accredited agencies. Order from the Society of Motion Picture Engineers, Inc., 20th and Northampton Sts., Easton, Pa., or Hotel Pennsylvania, New York, N. Y.

Published monthly at Easton, Pa., by the Society of Motion Picture Engineers.

Publication Office, 20th & Northampton Sts., Easton, Pa.

General and Editorial Office, Hotel Pennsylvania, New York, N. Y.

West Coast Office, Suite 226, Equitable Bldg., Hollywood, Calif.

Entered as second class matter January 15, 1930, at the Post Office at Easton, Pa., under the Act of March 3, 1879. Copyrighted, 1940, by the Society of Motion Picture Engineers, Inc.

Papers appearing in this Journal may be reprinted, abstracted, or abridged provided credit is given to the Journal of the Society of Motion Picture Engineers and to the author, or authors, of the papers in question. Exact reference as to the volume, number, and page of the Journal must be given. The Society is not responsible for statements made by authors.

OFFICERS OF THE SOCIETY

* *President:* E. A. WILLIFORD, 30 East 42nd St., New York, N. Y.

* *Past-President:* S. K. WOLF, RKO Building, New York, N. Y.

* *Executive Vice-President:* N. LEVINSON, Burbank, Calif.

** *Engineering Vice-President:* D. E. HYNDMAN, 350 Madison Ave., New York, N. Y.

* *Editorial Vice-President:* J. I. CRABTREE, Kodak Park, Rochester, N. Y.

** *Financial Vice-President:* A. S. DICKINSON, 28 W. 44th St., New York, N. Y.

* *Convention Vice-President:* W. C. KUNZMANN, Box 6087, Cleveland, Ohio.

* *Secretary:* J. FRANK, JR., 356 W. 44th St., New York, N. Y.

* *Treasurer:* R. O. STROCK, 35-11 35th St., Astoria, Long Island, N. Y.

GOVERNORS

* M. C. BATSEL, Front and Market Sts., Camden, N. J.

* J. A. DUBRAY, 1801 Larchmont Ave., Chicago, Ill.

** A. N. GOLDSMITH, 444 Madison Ave., New York, N. Y.

** H. GRIFFIN, 90 Gold St., New York, N. Y.

* P. J. LARSEN, 29 S. Munn Ave., East Orange, N. J.

* L. L. RYDER, 5451 Marathon St., Hollywood, Calif.

** A. C. HARDY, Massachusetts Institute of Technology, Cambridge, Mass.

* H. G. TASKER, 14065 Valley Vista Blvd., Van Nuys, Calif.

* Term expires December 31, 1940.

** Term expires December 31, 1941.

LARGE SIZE NON-ROTATING HIGH-INTENSITY CARBONS AND THEIR APPLICATION TO MOTION PICTURE PROJECTION*

D. B. JOY, W. W. LOZIER, AND R. W. SIMON**

Summary.—The high-intensity, direct-current arc between small, copper-coated carbons operated in coaxial alignment without rotation with a reflector optical system has achieved a widespread and growing popularity over the past few years for theatrical projection of motion pictures. This type of light-source has now been extended to include larger carbons and higher currents. These larger carbons of this type with the proper optical system will give substantially higher light on the motion picture screen.

Fundamental facts about the arc behavior and the conditions necessary to obtain stable and steady operation with these larger carbons are described. The correlation of the luminous characteristics of the arc with the optical system is reviewed. The performance of a new arc with a suitable optical system is given from the standpoint of offering possibilities for projection. Carbon consumption rates, arc current and voltage, and light on the screen are discussed.

Throughout the entire history of motion picture projection there has been constant progress in improving the efficiency and quality of the projection and the amount of light available on the screen. From the beginning, light for projection in motion picture theaters has been furnished almost exclusively by the carbon arc because of its high intrinsic brilliancy. However, the early carbons, and optical systems used to utilize their light, were a far cry from the carbons, lamps, and optical systems of today. Some of the more important changes are the application of the high-intensity arc to motion picture projection,^{1,2} making possible the large theaters of today; the use of a mirror and small carbons instead of a condenser and large carbons for low-intensity arc projection;^{3,4} improvements in condenser lenses for high-intensity carbons; the advent of the so-called "Hi-Lo" high-intensity reflecting arc lamp; and more recently, the extension of the high-intensity arc on an economical basis to the medium and small

* Presented at the 1939 Fall Meeting at New York, N. Y.; received November 13, 1939.

** National Carbon Company, Fostoria, Ohio.

theaters by the simultaneous improvement in mirror optical systems, and simplification of high-intensity lamp design made possible by the development of the small size, non-rotating, copper-coated "Suprex" carbon.^{5,6} These simpler types of high-intensity reflecting arc lamps and "Suprex" carbons have become standard equipment in a majority of the medium size theaters.

The characteristics of this system have been described before;^{5,6} two of its outstanding features are high efficiency and simplicity. The ever-present demands for increased screen illumination have led to research to extend these high-intensity arcs with non-rotated carbons to larger sizes using the reflector system. The purpose of this paper is to present for consideration and to describe the characteristics of larger-size non-rotating high-intensity direct-current carbons and discuss means of utilizing them in a manner which will make it possible to double the screen light obtainable with systems in common use today, and to do this in some cases with less energy input into the arc. These results represent several years of research and development work on the theoretical and practical aspects of the problem.

(1) EFFECT OF HIGHER CURRENT ON ARC BEHAVIOR

The accepted practice of not rotating the positive carbon and the approximately coaxial alignment of the positive and negative carbons have resulted in desirable mechanical simplification of the lamp mechanism and the problem of arc control. This arrangement has given stable burning with 6-mm, 7-mm, and 8-mm "Suprex" positive carbons, the latter of which is used with currents up to 65 amperes. Attempts to use a 9-mm positive carbon in the lamps designed for "Suprex" carbons met with serious difficulties when the arc current reached approximately 75 amperes. At about this current a transition was observed in the nature of the arc stream. This transition was characterized by the occurrence of a relatively dark "tongue" in the arc stream which appeared to originate at the tip of the negative carbon and extend some distance into the arc stream. The appearance of the arc stream at currents below and above this transition point is shown in Fig. 1(A) and (B), respectively. This phenomenon of the appearance of this tongue in the flame from the negative carbon was observed and described some years ago by Bassett.⁷ With the coaxial alignment of electrodes, this tongue from the negative carbon is directed into the positive crater and causes the arc to become unstable, and the light is erratic and unsteady. At cur-

rents considerably higher than 75 amperes, this tongue goes over to the familiar bright inner "core" or tongue appearing to be attached to the negative carbon of standard well known arcs such as the 125-ampere arc between the 13.6-mm high-intensity positive carbon and $\frac{7}{16}$ -inch "Orotip" negative carbon. In this latter case the negative carbon is used at an angle with the positive and the bright tongue in the arc streams up in front of the positive crater instead of directly into it, and so causes no instability.

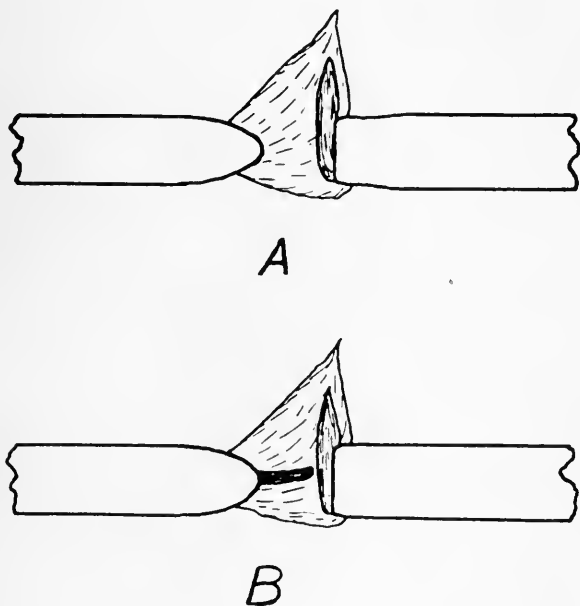

FIG. 1. Sketches showing the appearance of the direct-current arc with coaxially aligned electrodes: (A) With no negative "tongue"; (B) with negative "tongue."

Different factors were observed to have some small effect on the current at which this instability occurs but in no case was a factor of safety obtained which was sufficient to insure reliable operation with the large non-rotated carbons in coaxial alignment. However, it was observed that very satisfactory operation could be obtained without rotation of the positive carbon when the negative carbon was placed at an angle with the positive carbon, the range of 30 to 40 degrees appearing to give best results. Other angles of burning than

the range suggested may be made desirable by the use of auxiliary magnetic flux or by other design features of the lamp.

With this arrangement, it is possible to burn large-diameter non-rotated high-intensity positive carbons at high currents. In fact, it has been possible to burn positive carbons 15 mm in diameter above 150 amperes, with indications that still larger carbons and higher currents can be used under these same conditions. Operation is steady and easily controlled without the use of auxiliary magnetic flux.

(2) CHARACTERISTICS OF THE D-C ARC WITH ANGULAR-TRIM AND NON-ROTATING CARBONS

With this knowledge of the proper method of burning these larger carbons without rotation of the positive carbon, we proceeded to develop copper-coated positive carbons in sizes appreciably larger than the present 6- to 8-mm "Suprex" carbon range and having desirable characteristics for angular-trim reflecting arc lamps. We have also included in our development for angular-trim burning, carbons of the smaller diameters and have data on positive carbons (with suitable negatives) for this purpose ranging from 5-mm to 15-mm in diameter in 1-mm steps.

TABLE I

Burning Characteristics of 11-Mm Special Non-Rotated Positive Carbons and $\frac{3}{8}$ -Inch Negative Carbons Burned at 35° Angle

Current	Approximate Arc Voltage	Consumption (Inches per Hour)		Intrinsic Brilliancy at Center of Crater Candles per Sq Mm	Total Crater Candle-Power
		Positive	Negative		
110	56	13	2.3	640	30,000
115	60	16	2.4	700	35,000

Burning characteristics of an 11-mm copper-coated non-rotating positive carbon with a suitable negative carbon are given in Table I. This non-rotating angular trim gives steady light and has stable operating characteristics at the current and voltage indicated. It has been designed to give a higher intrinsic brilliancy than the 8-mm "Suprex" at its maximum current of 65 amperes. A comparison of the intrinsic brilliancy distribution across the crater face of these two carbons is given in Fig. 2. This figure shows also the relative size of the light-source from the 11-mm carbon compared with the 8-mm "Suprex" carbon. The question of how most efficiently to take advantage of this increased brilliancy and larger source diameter in

motion picture projection brings up the consideration of the properties of the optical system.

(3) POSSIBLE APPLICATION TO OBTAIN MORE LIGHT ON MOTION PICTURE SCREEN

The experiences gained with the reflector type lamps used with "Suprex" carbons provide much useful data on which to base our present considerations. Wide-angle elliptical reflectors having a

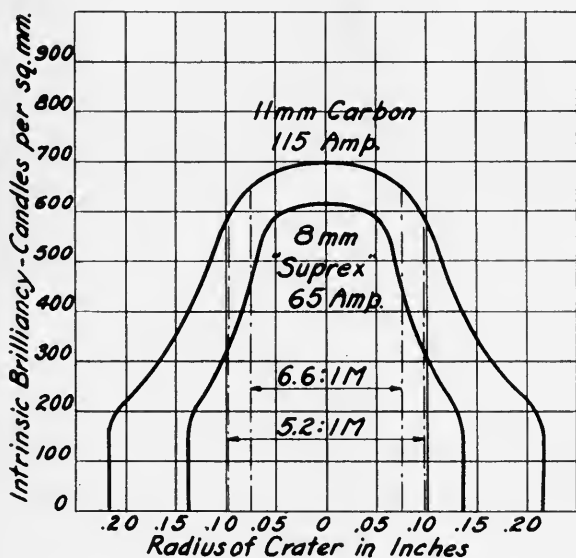

FIG. 2. Comparison of the intrinsic brilliancy and size of the crater of the 8-mm "Suprex" positive at 65 amperes in a horizontal trim, and the 11-mm carbon at 115 amperes in an angular trim.

collecting angle of approximately 145 degrees are employed with "Suprex" carbons, and the magnification ratio of these mirrors is about 6.5 to 7.0. The portion of the crater brilliancy curve of the 8-mm "Suprex," which, when magnified 6.6 times, falls within the diagonal of the sound projection film aperture, is shown in Fig. 2. Therefore, this shows approximately the portion of the "Suprex" crater light which is used in motion picture projection today. It is evident that the larger crater of the 11-mm Special carbon will permit a smaller magnification than 6.6:1 and still obtain good coverage

on the aperture. For example, the portion of the curve utilized with a magnification ratio of 5.2:1 is shown in Fig. 2. The 145-degree 6.6:1 elliptical reflector requires an $f/2.3$ projection lens to pass all the light which passes through the center of the film aperture. If the magnification of the mirror were reduced to 5.2:1 while still maintaining a large collecting angle, the relative aperture or "speed" of the system would be increased and a projection lens of higher "speed" could be filled.

The various factors affecting the screen illumination, including source brightness and speed of the optical system, have been discussed previously.^{8,9,10} Applying the principles discussed in those articles to the data in Fig. 2, it is evident that while the 11-mm carbon would

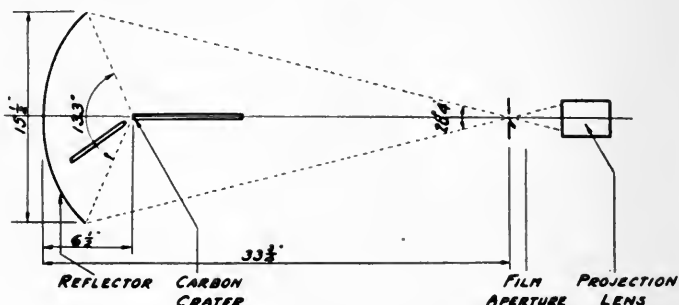

FIG. 3. Diagram of the $f/2.0$ reflector arc system.

give significant increase in screen light with an $f/2.3$ optical system, this increase will be more outstanding if used with a faster optical system.

TABLE II

Screen Light Measurements on 11-Mm Special Non-Rotated Copper-Coated Carbons in Angular Trim

Current	Approximate Arc Voltage	Screen Lumens; No Film Shutter	Screen Distribution Sides to Center
110	56	14,000	70%
115	60	16,000	70%

In order to determine experimentally the possibilities of the 11-mm non-rotated copper-coated carbons, an experimental burner was assembled. An experimental mirror of proper magnification and angular pick-up¹¹ was obtained from the Bausch & Lomb Optical

Company. The carbons were not rotated and the negative carbon was placed at an angle of 35 degrees from the positive carbon. The optical system of this lamp is shown in Fig. 3, where the various dimensions of the reflector system are given. A standard sound-film projection aperture was used in the system without a film shutter. Screen light measurements were taken with a 4-inch focal length $f/2.0$ experimental "Cinephor" type projection lens.¹¹ Weston photonic cells equipped with "Viscor" filters were placed at the center, sides, and corners of the screen image to measure screen illumination and screen distribution.

The results of these screen light measurements are shown in Table II for the same carbons whose burning characteristics are given in Table I.

TABLE III

Screen Light Obtainable with Various Carbons and Optical Systems

Carbons	Amperes	Lamp Optical System	Projection Lens	Screen Lumens; No Film Shutter
8-7-mm "Suprex"	65	Elliptical mirror	$f/2.3-f/2.5$	6000-8500
13.6-mm H.I. Pos.	125	Condenser type	$f/2.3-f/2.5$	6000-9000
$7/16$ " "Orotip" Neg.				
13.6-mm Super H.I. Pos $1/2$ " "Orotip" Neg.	180	Condenser type	$f/2.3-f/2.5$	8000-10,000
11-mm Special Non-rotated C.C. Pos. $3/8$ " Neg.	115	$f/2.0$ Mirror de- scribed in this paper	$f/2.0$ lens described in this paper	16,000

In order to understand better the significance of the values given in Table II, they should be compared with the amount of screen light obtained with conventional lamp systems and carbons in use today for motion picture projection. Such figures can be only approximate because of the many factors which affect the total luminous flux falling on the screen.

Table III shows the approximate amounts of screen light obtained with various well known carbons and optical systems, and that the new 11-mm carbon and $f/2.0$ reflector system described in this paper will give as much as twice the light of the two high-intensity systems most widely used today—the 8-mm "Suprex" positive carbon with mirror type lamps and the 13.6-mm H.I. positive carbon at 125 amperes with condenser type lamps.

It is of interest to compare the 11-mm non-rotated positive carbon and the 8-mm "Suprex" carbon each with its appropriate optical system, as regards the rapidity with which the screen light and screen distribution change as the positive carbon is moved along its axis away from the focal point of the mirror. This comparison is shown in

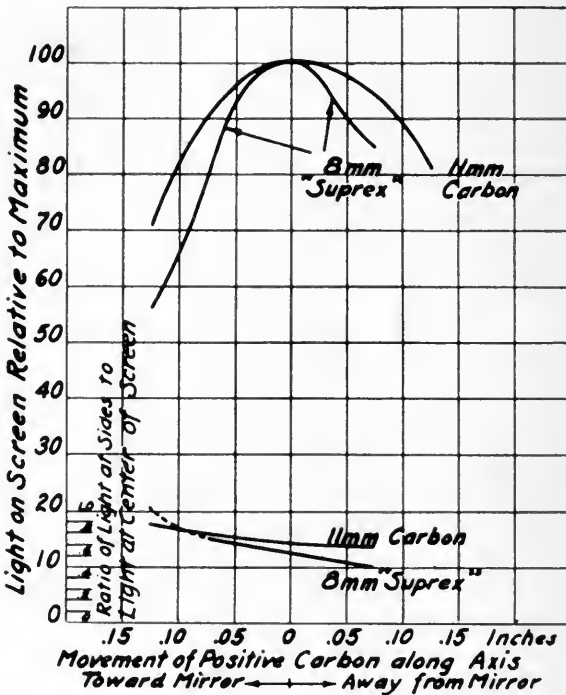

FIG. 4. Curves showing the change in total screen light and the distribution of screen light with movement of positive carbon, for the 8-mm "Suprex" and the 11-mm carbon used with their respective optical systems.

Fig. 4, and gives an indication of the "flexibility" of the two arcs with their respective optical systems. It can be seen that the 11-mm trim has a better distribution of light on the projection screen. For example, at the focal point of the reflector or the position of maximum light, the 11-mm carbon with its optical system gives a light at the sides equal to 70 per cent of that at the center, whereas the "Suprex" carbon gives a light of 63 per cent at the sides compared with the center.

If the positive carbon is moved either toward or away from the reflector and the current and relative position of the negative carbon with respect to the positive are kept constant, the total light on the projection screen will change for these two carbons and optical systems according to the two top curves shown in the figure, and the distribution will change as shown by the two bottom curves in the figure. It is evident that the light falls off much more rapidly with the movement of the carbon for the 8-mm "Suprex" combination than for the 11-mm angular-trim non-rotating carbon combination. It is also evident that with the movement of the positive carbon the distribution of light changes much more rapidly for the "Suprex" carbons than for the 11-mm carbons in their respective lamp systems. For a decrease from the maximum of 10 per cent in the total light on the screen, the 11-mm carbon in its optical system can move over a distance along its axis approximately 60 per cent greater than that required to give the same reduction with the 8-mm "Suprex" carbon. For a range in the side-to-center distribution ratio of light on the projection screen between 65 and 75 per cent, the 11-mm carbon with its optical system can move twice the distance of the 8-mm "Suprex" with its optical system. In other words, this 11-mm carbon with the optical system suggested gives a light on the projection screen which is about twice as stable with respect to carbon movement, *etc.*, as the 8-mm "Suprex" carbon in the commercial lamps of today. At the distributions indicated by the dotted portions of the curve in the figure, the 8-mm "Suprex" gives non-uniform color over the screen, whereas the screen distribution with the 11-mm carbon is satisfactory over the entire range shown.

This greater "flexibility" of the 11-mm carbon with its optical system is at least partially explained by reference to Fig. 2, where it is shown that the magnification of the optical system for the 11-mm carbon is so chosen as to use a portion of the crater which is relatively uniform in brilliancy. With a $5.2\times$ magnification of the crater of this carbon, the edge of the useful portion of the crater which is normally imaged on the corners of the aperture shows a reduction of only 15 per cent in brilliancy compared with the center; whereas with the 8-mm "Suprex" crater and $6.6\times$ magnification, this reduction is 25 per cent.

With the increased amount of light from the 11-mm carbon and $f/2.0$ optical system indicated in Table III, there will be an increased amount of heat on the film. Measurements have shown that the

spectral distribution of radiant energy with this 11-mm positive carbon is similar to that of the other high-intensity arcs, and therefore the radiant energy falling on the film is approximately in proportion to the light passing through the film aperture. Heat measurements have been made with a blackened receiver fastened to a thermocouple and mounted in the plane of the film aperture. These indicate that this 11-mm carbon burned at 115 amperes in the $f/2.0$ reflector lamp will put about 60 to 70 per cent more radiant energy on the film aperture than the conventional mirror or condenser type systems indicated in Table III. It may be advisable to make special provision to take care of this increase in heat at the film aperture. Methods for doing this are well known to the industry.

A further idea of the possibilities for motion picture projection with this 11-mm carbon and the $f/2.0$ reflector system is obtained from a consideration of the dimensions of the screen which can be adequately illuminated. Combining the data of Table II with the transmission of the film shutter, it is seen that about 8000 lumens can be put on the screen with the film shutter running and with no film in the gate. Under the above conditions the recommendations of the Projection Practice Committee¹² call for a screen brightness of 7 to 14 foot-lamberts. Assuming a diffusing screen of 0.75 reflectivity, it is possible to illuminate a screen approximately 34 feet in width to the minimum recommended brightness and 24 feet in width to the maximum recommended brightness. This is about 60 to 100 per cent greater screen area than can be illuminated to this level by the reflector or condenser lamp systems in common use today.

REFERENCES

¹ BASSETT, P. R.: "The High Power Arc in Motion Pictures," *Trans. Soc. Mot. Pict. Eng.*, No. 11 (1920).

² BENFORD, F.: "The High Intensity Arc," *Trans. Soc. Mot. Pict. Eng.*, No. 24 (1925), p. 71.

³ BASSETT, P. R.: "The Progress of Arc Projection Efficiency," *Trans. Soc. Mot. Pict. Eng.*, No. 18 (1924), p. 24.

⁴ STARK, S.: "Reflector Arc Projection—Some Limitations and Possibilities in Theory and Practice," *Trans. Soc. Mot. Pict. Eng.*, No. 23 (1926), p. 94.

⁵ JOY, D. B., AND DOWNES, A. C.: "Direct-Current High-Intensity Arcs with Non-Rotating Positive Carbons," *J. Soc. Mot. Pict. Eng.*, **XXII** (Jan., 1934), p. 42.

⁶ JOY, D. B., AND GEIB, E. R.: "The Non-Rotating High-Intensity D-C Arc for Projection," *J. Soc. Mot. Pict. Eng.*, **XXIV** (Jan., 1935), p. 47.

⁷ BASSETT, P. R.: "The Electrochemistry of the High-Intensity Arc," *Trans. Amer. Electrochem. Soc.*, **XLIV** (1923), p. 153.

⁸ HARDY, A. C.: "The Distribution of Light in Optical Systems," *J. Frank Inst.*, **203** (Dec., 1929), p. 773.

⁹ HARDY, A. C.: "The Optics of Motion Picture Projectors," *J. Soc. Mot. Pict. Eng.*, **XIV** (March, 1930), p. 309.

¹⁰ COOK, A. A.: "A Review of Projector and Screen Characteristics and Their Effects upon Screen Brightness," *J. Soc. Mot. Pict. Eng.*, **XXVI** (May, 1936), p. 522.

¹¹ We gratefully acknowledge the services of the Bausch & Lomb Optical Company in supplying the $f/2.0$ experimental reflector and 4-inch $f/2.0$ experimental Cinephor type projection lens used in these tests.

¹² Report of the Projection Practice Committee, *J. Soc. Mot. Pict. Eng.*, **XXIX** (July, 1937), p. 39.

THE DEVELOPMENT AND PRACTICAL APPLICATION OF THE TRIPLE-HEAD BACKGROUND PROJECTOR*

BYRON HASKIN**

Summary.—Up to a recent date, background process work had been limited to the size of a picture that could be successfully illuminated through a single projecting machine.

The origination of a combination of projectors superimposing identical prints of the same background on the screen simultaneously compounded the light delivery of a single machine and therefore greatly expanded the scope of background process photography for natural color and black-and-white.

In discussing the Warner Brothers' compound or triple-head projector, the author would like to quote from the Academy Award which this apparatus received for 1938: "for pioneering the development, and for the first practical application to motion pictures of the triple head background projector"—and give a brief history of the circumstances that led to the inception of the principle of compound projection in process work, along with some of the steps by which this principle was brought to mechanical application to motion picture production.

This discussion will be general, since the mechanical details have already been described comprehensively and excellently by A. F. Edouart.¹

In the fall of 1937 Warner Bros. Pictures, Inc., scheduled a picture *Gold Is Where You Find It* which was to be photographed in Technicolor. The story was a melodrama of the early days of hydraulic mining in California, and had as its climax a sequence involving the flooding of a huge valley wherein were conducted these mining operations. For obvious economic reasons a great many of the scenes of the climax had to be done by "trick work"—miniatures, and process projection shots utilizing the miniature backgrounds.

* Presented at the 1939 Fall Meeting at New York, N. Y.; received October 12, 1939.

** Warner Bros. Pictures, Inc., Burbank, Calif.

In planning and designing our process shots it soon became apparent that to achieve the required scope and dramatic effects to put the sequence over, we were faced with an apparently insurmountable barrier. The size of picture that had been successfully projected and rephotographed in color at that time was so small as to be practically useless in obtaining the scenes that the story demanded.

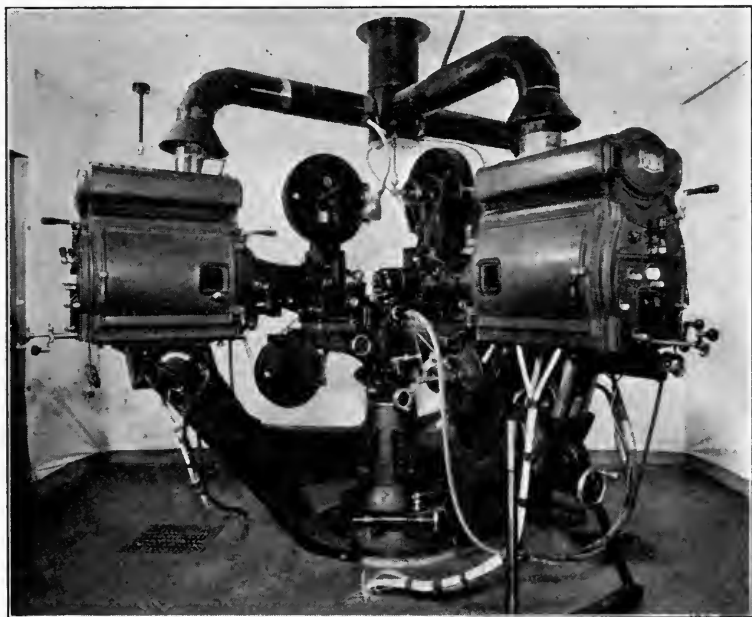

FIG. 1. Rear view, showing lateral panning screw at bottom of base; also swiveled exhaust pipes overhead.

The only development at that time was the single projector, equipped with the high-intensity and sundry types of light-sources which, in color process work, delivered as a maximum a picture 9×12 feet in size.

Our foreground settings consisted mainly of flumes, hydraulic guns, miners' shacks, *etc.*, all too big to be identified properly with a picture so small. We were therefore forced to attempt to break the limitations which bound us.

Reasoning that the practical maximum in light delivery had been reached through the single projector, the thought occurred that,

provided additional projectors could be superimposed over the one to compose a single image, the brilliancy of the picture should compound respectively and, by ratio, expand to the size required. After discussion relative to the amount of light needed we determined to attempt to superimpose three projectors because, in theory, this compounding of light would be enough.

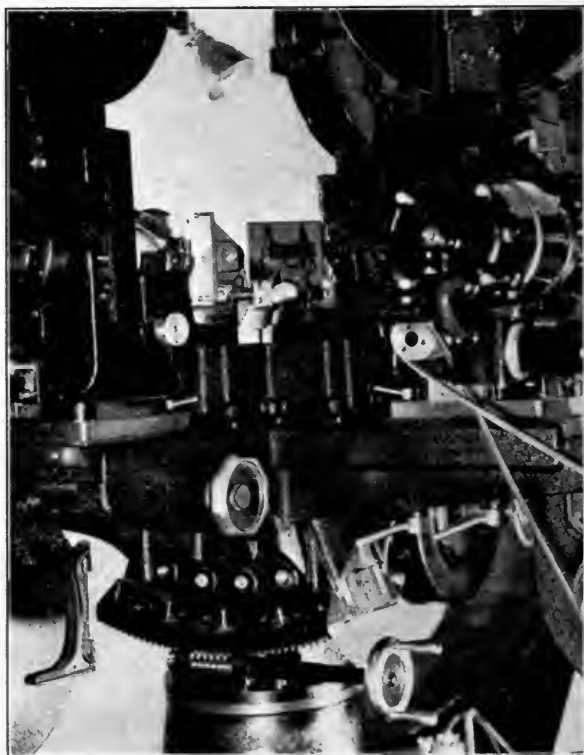

FIG. 2. Partial side view, showing vertical tilt device; also focusing handwheel in center. Rear view of mirror and adjustment screws.

We recognized at once that the problem of superimposing projectors was mainly a problem of parallax. Being faced with the necessity of using our existing equipment, which by its very size, when placed side by side, would introduce an impossible parallax condition, we were forced to devise a "bread-board" set-up.

This set-up was a *T*-shaped base of channel-iron, on the stem of which was mounted a center projector and on the two side arms of which were other projectors at right angles to the central machine, casting their pictures in the same plane through reflecting mediums consisting of 4-inch optical prisms. These prisms were separated laterally by a minimum distance that would clear the beam of the central machine, thereby making the three projecting beams originate from an area sufficiently small to cause no practical problems of parallax.

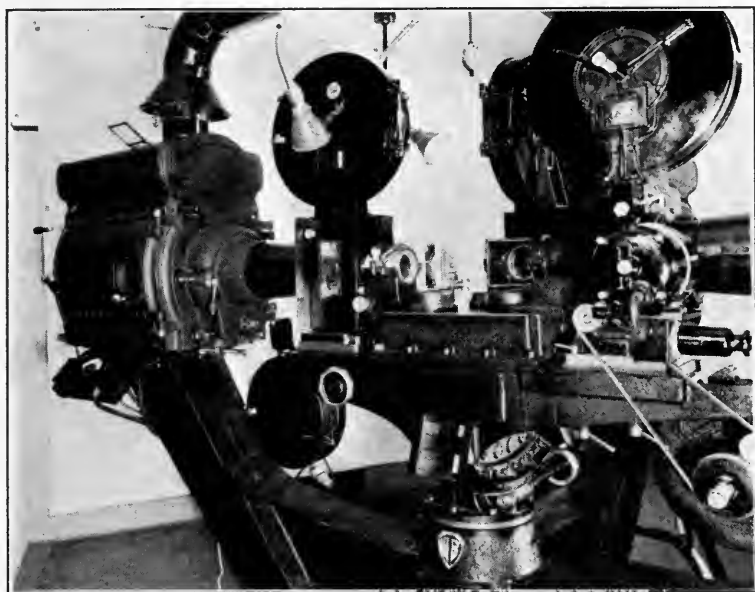

FIG. 3. Quarter front view, showing means of rotating the projector and optical bedplate about the optical axes of side projectors.

During the period of developing and applying this crude model to actual production conditions we were faced with many difficulties before it became practicable. Our first consideration, and the basis upon which the entire success of the experiment rested, was the question of whether our standard projector movements would prove steady enough for the absolute superimposition required. This, thanks to the precision of the standard Bell & Howell movements that we use, proved to be more than adequate. Our first projection of identical

charts on the three machines, while not superimposed absolutely as to position, showed no detectable creep or crawl. The foundation for practical application was there.

The next problem was the development of a micrometer adjustment for positioning the reflecting mediums of the outboard projector beams both laterally and vertically so that their images could be superimposed upon the image of the central beam with a minimum of time and trouble and, once superimposed, remain fixed.

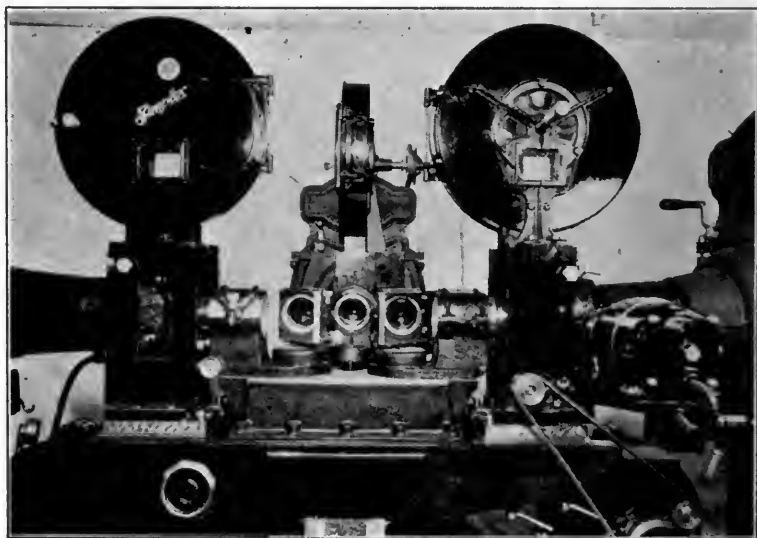

FIG. 4. Front close-up view, showing lens mounts, mirror holders, and optical bench. The Bell & Howell camera movement can be seen through the window in the left-hand head; sync motor on right-hand head.

The type of mounting was solved, but we found that the light loss and the weight of the 4-inch prisms that we first used hindered us in many ways. After experimentation, we ended with our present type of reflecting medium which is a fused quartz optical flat, surfaced to $1/2$ wavelength, aluminized first surface by the General Electrical Co. hardening process.

With this "bread-board" set-up we successfully completed our assignment of *Gold Is Where You Find It* in the early part of 1938, and through actual production working conditions were able to formulate all the requirements that eventually went into our finished triple-head projector.

A major requisite for production conditions was that the entire unit could be adjusted easily laterally and vertically to position the picture on the screen without inaccuracy of superimposition. To meet this requirement a gun-mount type of base was designed which swings laterally around an axis equidistant from the three lenses and rotates vertically about the optical axis of the two outboard lenses, thus never altering the focal distance of any of the lenses from the screen during the necessary "positioning" of the picture for the shot.

Another major requisite was rigidity of all the component parts in

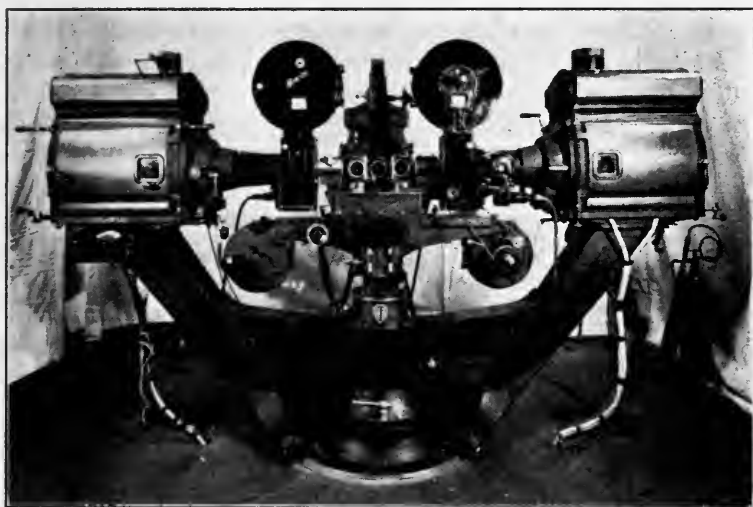

FIG. 5. Front view, showing division of lamp brackets from main base. The vertical load is carried on rollers in contact with the track forming the rim of the floor base. The projectors and optical bench are integral with the main rotating base.

relation to the inertia of the base. In order to avoid any disturbance to the projector-lens base and consequently to the rigidity of the optical components, when the lamp houses were being manipulated all lamp-house mountings were separated from the portion of the base that contains the optical parts. The lamps, however, were attached to the sub-base so that they would stay in their optical position while the unit is being rotated.

Arriving at the design of the optical base or optical bench, we found through developments of focusing apparatus that the whole set-up would be far more rigid if the lenses were solid to the bench

and the projectors moved back and forth on generous dovetailed ways to obtain focus on the screen. We therefore have rigid lens mounts dowelled to accept matched sets of lenses so that they are always the same focal distance from the screen, thereby eliminating any adjustment for superimposition when changing the size of the picture.

These problems that we solved and incorporated into the finished product constitute the main features of the triple-head as it differs from the standard single unit. In the construction of the finished machine we were fortunate in having had a thorough working experience with the "bread-board" set-up, and because of this we were able to design and build a finished product quickly without any further modification.

In the practical application of the finished triple-head projector to working conditions of motion picture production, we bent every effort to avoid delays in the actual lining up and shooting of scenes during the time an expensive production company was on the set.

It was our hope to be able to shoot a sequence of process shots with the same ease and expediency as was formerly done with the single unit. Mobility had been an important feature of the single unit. To gain this for the triple-head and at the same time not sacrifice its rigidity we placed it on a concrete foundation in a sound-proof booth which operates somewhat like the turret of a battleship. This permits us to have several screens set up within the radius of the rotating field of the booth.

Results during a period of constant use have proved that the triple-head is as practicable and economic as was the single unit. While the origination and completion of compound background projection came through a necessity for increasing the scope of process shots in color, it has proved through usage an important development in black-and-white work as well. Shots of a magnitude hitherto impossible have been successfully completed. Effects where great depth of focus is required by stopping down on the photographic lens have been made. Whatever had been done before its creation was enlarged in proportion by the use of the triple-head projector.

REFERENCE

¹ EDOUARD, A. F.: "Paramount Triple-Head Transparency Process Projector," *J. Soc. Mot. Pict. Eng.*, XXXIII (Aug., 1939), p. 171.

MOTION PICTURE AUDITORIUM LIGHTING*

B. SCHLANGER**

Summary.—The various functions of motion picture theater auditorium lighting are discussed. Particular analysis is made of the lighting which is used during the period in which the motion picture is projected. Past and present lighting practices in this respect are explained. The advantages and disadvantages of these practices, and a new type of lighting are discussed. It is proposed that the illumination levels of the interior surface of the auditorium be at greater levels than have been heretofore found to exist. A definite relationship between the screen brightness and that of the auditorium surfaces is indicated as desirable. Recent tendencies toward higher screen brightnesses have made a very low intensity lighting in the auditorium much more undesirable, and therefore have made it more important to arrive at a new solution for motion picture auditorium lighting. The realism of the projected picture can be considerably heightened by proper surface illumination. Controlled reflected light coming from the screen and re-reflected from the interior surfaces is discussed as a medium for lighting.

The auditorium of the motion picture theater is still being illuminated by the same methods, more or less, used in lighting the auditorium of the stage theater. Yet, the lighting requirements in the two cases are decidedly different. These differences are best understood when the shapes and sizes of the auditorium and the motion picture in the one case, and of the auditorium and stage opening in the other case, are compared. Fig. 1 shows the amounts of interior surface *vs.* the motion picture and stage opening areas within the spectators' range of vision. Due to the necessarily oblong shape of the motion picture auditorium and the necessarily square-shaped character of the stage theater auditorium, there is an important difference between the ratios of the interior surface areas and the areas comprising the motion picture or the stage opening. In each case there is a brightly illuminated area—in the one, the motion picture; in the other, the stage opening. Note that the highly illuminated area in the stage theater occupies $\frac{3}{5}$ of a 60-degree horizontal range of vision, and in the case

* Presented at the 1939 Fall Meeting at New York, N. Y.; received Oct. 16, 1939.

** New York, N. Y.

of the motion picture only $\frac{1}{8}$ of a 60-degree horizontal range of vision. This comparison shows that in the stage theater the surface area within the spectators' range of vision but outside the highly illuminated area is relatively small and therefore could remain without illumination or with optional illumination without any detriment to the proper unfolding of the stage performance. But in the case of the motion picture auditorium, the surfaces within the range of vision occupy a great proportion of the entire field, making it important to illuminate these surfaces so that they bear an appropriate relation and setting to the illuminated motion picture.

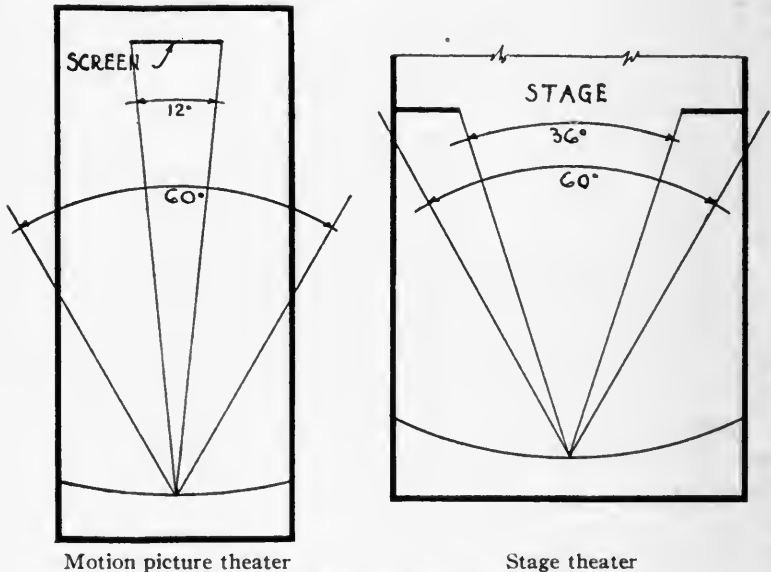

FIG. 1. Interior surfaces within range of vision.

For the same reasons that make it necessary to illuminate the auditoriums differently, it is also necessary to consider the design of the interior surfaces for each case. The decoration of the stage theater may be optional, but in the case of the motion picture theater, fixed traditional architectural decoration must be completely eliminated from the interior surfaces seen in combination with the motion picture. These surfaces must be neutral, and any divergence from the utmost simplicity in their treatment must be limited to changes in light intensity in the various parts for the purpose of creating a suitable setting for the picture.

Past practices have totally ignored this approach to motion picture auditorium lighting, giving undue emphasis to irrelevant decorative lighting and thereby detracting from, rather than adding to, the effectiveness of the picture presentation.

The lighting of the motion picture auditorium can be separated into three different and distinct functions:

(1) *Traffic Lighting*.—To permit patrons to move about safely to and from the seats.

(2) *Intermission or Decorative Lighting*.—Used solely for effect, during the waiting periods before and after picture showings.

(3) *Complementary Auditorium Surface Lighting*.—Used during the picture projection periods.

This paper deals primarily with the third type mentioned, but a few remarks regarding the first two functions are important at this point.

Traffic light should be controlled so that all the light intended for such purpose should fall upon the floors of the aisles and on the seated audience, avoiding any spill of light upon the wall and ceiling surfaces that come within the spectators' range of vision while viewing the picture. It is inadvisable to allow traffic lights to play upon such surfaces because the intensity and placement requirements of traffic light and other lights used during picture projection periods are distinctly different. Many successful methods of confining lighting to restricted areas have been developed and may be applied to traffic lights.

Intermission or decorative lighting may be optional, provided that such lighting is not used while the picture is being projected and that the lighting devices are concealed or rendered unobtrusive if within the range of vision while viewing the picture. The illuminated picture, if allowed to be, is the chief source of illumination of the motion picture auditorium during the projection period. Lack of recognition of this fact is the reason why the lighting problem has never been approached properly. Most screens have diffusive surfaces and screen illumination levels have increased considerably, with the result that a considerable amount of light is reflected from the screen to the interior surfaces of the auditorium. Hence the problem of lighting is concerned with both the proper absorption or re-reflection of this light as well as with the introduction of secondary light-sources.

Any contention that the use of light reflected from the screen should not be encouraged is not justified because it is exceedingly more ex-

pensive to use instead completely secondary lighting sources for the illumination. Furthermore, secondary sources of illumination can not, within practical limits, be made to supply the desirable "synchronous" type of lighting to be described later in this paper.

There are three or four possible theories of illumination during the picture projection period, leading to entirely different psychological effects upon the viewer. It may be contended that the entire auditorium should approach an apparent total blackness, leaving the picture in sharp contrast to its surroundings. In this case the necessary traffic lights, exit signs, and the screen light re-reflected from the audience is very likely to destroy the supposed illusion—and in this instance, of course, the light reflected from the screen is supposed to be completely absorbed. To carry out the "dark" idea to its full extent, a major part of the walls and ceiling would have to be of an almost black, flat color, and a considerable number of the fixtures for traffic lights would have to be built in, to concentrate the light upon seats and the aisle floors. Yet, even if such a black effect were attainable economically, its desirability is questionable. A screen brightness of 7 to 14 foot-lamberts has been found desirable for the picture, and with such a screen brightness the dark auditorium surfaces and screen surroundings contrast objectionably with the picture. This is so in the case of the black-and-white picture, and more so with color pictures. When daylight or other bright scenes are shown, the dark surroundings become even more undesirable. Therefore, the dark auditorium may be psychologically unsuitable as well as a factor in visual fatigue due to the strong contrast between the picture and the surrounding darkness.

Another theory would have the interior surfaces absorb most of the reflected screen light so that only the illumination from secondary sources would be apparent on the interior surfaces; but the cost of electric current and the installation expense makes this method uneconomical when the lighting design is carried out properly. The method requires the use of indirect lighting, which is highly inefficient. The lighting must of necessity be fixed in intensity and color, with the result that an unfavorable effect is produced when contrasting dark and light scenes are projected on the screen. However, this scheme does mitigate somewhat the visual fatigue which may be experienced while viewing a bright picture in dark surroundings.

Some experimental work has been done recently with the idea of causing the intensity and color of the secondary sources of light to

change in conformance with the screen picture. This method will prove even more costly than the previous method, since elaborate electrical controls will be needed to synchronize the lighting of the screen and the interior. The scheme has all of the disadvantages of the music cue sheets that had to be supplied to each exhibitor in connection with the silent pictures; or of requiring each exhibitor to evolve a new light-synchronization scheme with each picture involved. These disadvantages indicate the impracticability of such an idea. The exhibitor should have no more to do than to project the picture properly and to let the picture create the mood. Certainly, the artist who is responsible for making the picture would not like to anticipate a thousand individual and different interpretations of illumination settings for the presentation of the picture.

The successful lighting method must—

- (1) Be reasonably inexpensive to install.
- (2) Cause the least visual fatigue while viewing a picture.
- (3) Create a desirable psychological effect.
- (4) Provide safe traffic lighting.

While the first two requirements are of basic importance, the third is one that goes beyond the field of lighting and tends to deal more with the intended mood of the picture. Yet, since it is the lighting that creates the setting for the picture, all the requirements must be thought of as one and the lighting problem must embrace them all. The psychological problem nevertheless is the important one, because it determines the extent to which the picture will be enjoyed.

The lighting methods previously discussed do not solve all the problems involved, especially that of creating the appropriate psychological mood, and a method is proposed by the author that would prove economical, relieve eye-strain, and make the picture presentation more realistic. The patron would not feel picture-conscious, and would more easily come to feel that he existed in the actual scene depicted upon the screen. The effect is achieved by a lighting scheme that eliminates any contrasting framework around the picture.

To achieve this effect, three steps must be taken: (1) All the interior surfaces, both ceiling and walls, seen in combination with the screen within a range of vision, must be in a white or nearly white color. (2) All such surfaces must be broken up into angularized planes or be of such surface textures that their brightness to the audience, under the light reflected from the screen, may be appropri-

ately controlled. The surfaces are designed so that in certain parts they will appear brighter than in other parts. The apparent brightness at any point is controlled by re-reflecting the light from the screen toward either the cheeks or the eyes of the patrons in the desired proportions. Light reflected away from the eyes of the spectators is also helpful because it helps to increase the traffic lighting level. As a solution to the third step the use of synchronous screen border illumination, contiguous to the screen, is suggested. The area immediately around the picture is a transitional lighting area between the screen and interior auditorium surfaces—the areas blend with one another, and as a whole are blended to the screen picture itself. The entire scheme of lighting is unified and related in all its parts.

The result is a decided simplification. The lighting in the area adjacent to the picture is synchronous with the lighting that happens to occur at the edges of the picture. The surfaces beyond this adjacent area pick up their light in small amounts from the entire picture; but as the distance from the screen increases the apparent brightness of the interior surfaces becomes lower, leaving them in darkness in areas outside the range of vision of the spectators.

It is contended that present screen maskings and lighting and architectural embellishments on these important surfaces in the interior are all distractions and, therefore, undesirable. A word of caution is appropriate here; *viz.*, the mere setting up of a screen in a white auditorium not designed properly will be even more distracting than the dark auditorium, or an auditorium with secondary illumination, because the screen light will re-reflect on the white surfaces in an uncontrolled and disturbing manner.

With this method properly developed, the secondary light-sources needed for moving about the theater could be limited to small pilot-lights made to hug the floor in aisles, passageways, *etc.*; and even then, these lights would be obvious only when especially dark sequences appear on the screen. As to emergency lighting, it is extremely simple to arrange emergency lights that would automatically switch on.

AUTOMATIC SLIDE PROJECTORS FOR THE NEW YORK WORLD'S FAIR*

FORDYCE TUTTLE**

Summary.—Special slide-changing projectors were designed and built for the Kodachrome exhibit in the Eastman building at the New York World's Fair. Eleven machines are synchronized so that panoramic scenes one hundred and eighty-seven feet long may be shown. Indexing of the slides is controlled by notches in a sound-film so that the entire program is automatic.

The slides in each machine are arranged in two rows, and the machines each have two gates and two complete optical systems. All the slides in one row are rigidly bolted to a ring-gear forty-eight inches in diameter. For each new picture one of the two ring-gears is spring-indexed into a new position. An optical compensator geared to the ring-gear corrects for any inaccuracies in indexing, and the image is optically "dowelled" on the screen.

The main feature of the Eastman Kodak Company's exhibit at the New York World's Fair is the Cavalcade of Color, a showing of projected Kodachrome slide pictures.

The audience faces a semicircular faceted screen which is 187 feet long and 22 feet high. Above and behind the audience is a projection room which houses eleven special projectors. No operator is in this room. Day in and day out the only act performed by any operator is that of threading and running a notched sound-film. The first notch on this film dims the house lights; the last brings them up for an intermission. Other notches between these two put on the show. At times, synchronized with voice and music, the pictures projected on the screens change from individual shots of homely interest to complete panoramic views of nature's beauty spots. Altogether, more than two thousand individual screen pictures can thus be shown in a complete cycle.

Possibly the most important single factor in making the show automatic is the use of incandescent lamps as light-sources. The individual pictures are approximately one inch by one and a quarter, or

* Presented at the 1939 Fall Meeting at New York, N. Y.; received December 27, 1939.

** Eastman Kodak Co., Rochester, N. Y.

somewhat smaller than either the standard Retina or Bantam frame sizes. To obtain enough light for the $213\times$ magnification on the screen, it was necessary to have a special lamp made and to design a high-efficiency condenser and objective system. The lamp is a

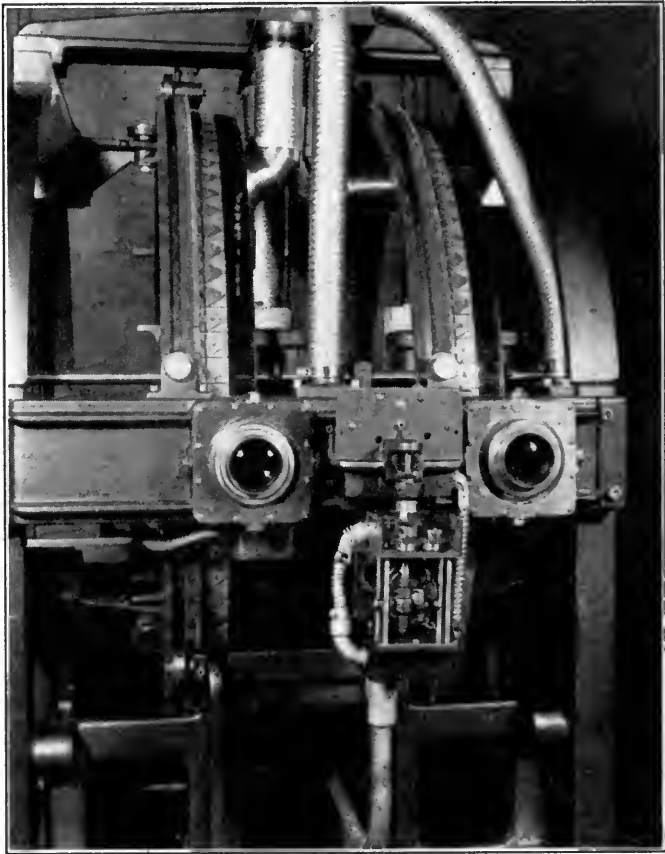

FIG. 1. General view of front of automatic slide projector, showing double projector system.

2500-watt, biplane, coiled coil, differentially wound, pressure-filled tungsten lamp which operates at a high color-temperature (3450°K). The condenser system is one quite free from spherical aberration, and consists of a plano-parabolic collection lens, two plano-spherical elements, and a plano-spherical field lens, the combination of which

images the filament to fill the diaphragm plane of the $4\frac{1}{2}$ -inch $f/2.0$ objective. The actual amount of light obtained with this system is 2250 lumens, giving better than six foot-candles illumination on the 17×22 -foot screens.

Some of the individual pictures used in the show are projected for periods as long as 20 seconds. For this reason it was found necessary to cool the film in the gate. Between the lamp and the gate a 4-inch ferrous sulfate liquid cell is used. Sulfuric acid has been added to the ferrous sulfate solution to retard deposition of oxidized material. The gate itself is enclosed by glass, and filtered air cooled to 50°F is blown over the film at a velocity of approximately 7000 feet per minute. The lamp is cooled by air at room temperature, circulated at the rate of approximately 100 cubic-feet per minute. The film, of course, is cemented on glass to prevent buckling and distortion in the hot gate.

During the change-over from one picture to the next, it is not necessary for the screen to go black. A change can be made almost instantly from slide to slide, or one picture can be faded gradually into the next in a slow cross-dissolve since every one of the eleven machines projecting onto the eleven individual screens is double-barrelled (Fig. 1). Each has two lamps, two gates, and two complete projection systems. During the time of projection from the left-hand gate of each of the eleven machines, new slides can be indexed into the right-hand gates; and as soon as they are positioned, by means of a shutter system, the left-hand pictures are faded out into the right-hand ones which allows new slides to be brought into the left-hand gates. The cross-dissolve shutters work in such a way that during the change-over the light to the screen remains constant. One picture can actually be substituted for another without alteration in the screen image if the registration of the two pictures is perfect on the screen.

Many effect pictures can be shown if the registration is satisfactory. A color picture can be changed into a monochrome; it is possible to go from front lighting to silhouette lighting on the same subject; and to show complete panoramic scenes by day and by night.

The big mechanical design job in making the projectors, then, was that of achieving precise registration. As noted, the film has to be cemented onto glass, so that it will not buckle or distort in the hot gate. The machines must be capable of handling some two thousand glass slides, keep them in order, and index them into position in such a way that the registration of the image on the screen seems to be perfect.

Many ways of doing this job were considered. The method finally selected has proved very satisfactory in actual practice. The film is cemented onto glass with the perforation holes located approximately with respect to the sides of the glass. The glass is then clamped and cemented onto metal carriers in an optical jig. The metal carrier has a machined face, which is used for locating it on the projector, and also gear-teeth which are used for registration purposes in the projector. The result of these cementing operations is to put the metal

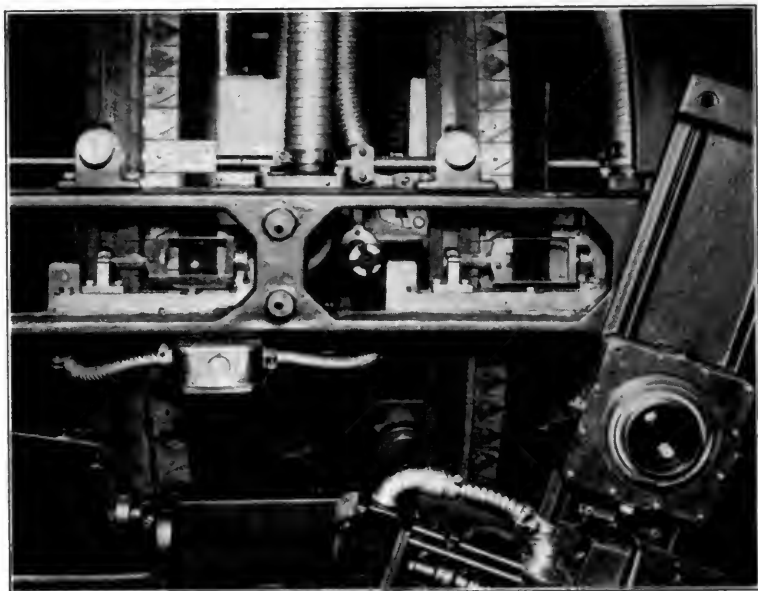

FIG. 2. Front with lens-plate removed, showing gear-teeth on slide-carriers and rotating plane-parallel plate for maintaining the picture stationary on the screen.

gear-teeth on the film, accurately located with respect to the perforation holes in the film. Once metal gear-teeth are on the film, they can be made to do some of the work of registration.

Ninety-six of these slide carriers with their cemented slides are then bolted onto a ring-gear. The gear-teeth of the individual slide carriers form a continuous spur-gear 48 inches in diameter. The glass plates overhang the metal carrier and form a cylindrical drum of glass plates about 46 inches in diameter. The whole ring-gear and glass-plate drum assembly is mounted to rotate in a vertical plane.

The lamp house and condenser system is inside the glass-plate drum, and the slides pass vertically through the gate.

Vertical and circumferential faces of the ring-gear are accurately machined. The ring-gear assembly rolls through the gate on precision ball-type roller bearings, riding on these vertical and circumferential surfaces. The bearings furnish accurate side-guiding for the pictures, which are rigidly attached to the ring-gear. They also force the pictures to stay in the focal plane.

The whole ring-gear, metal film-carrier, and glass-plate assembly

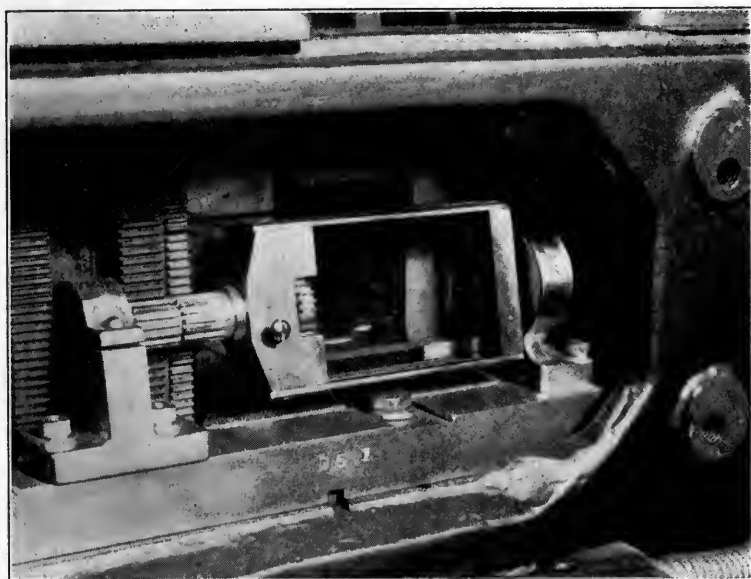

FIG. 3. Close-up of plane-parallel glass plate; note the pinion-gear engaged by the ring-gear and the gear on the slide-carrier.

weighs approximately two hundred pounds. In the indexing operation this 200-pound drum assembly is rotated one ninety-sixth of a revolution and stopped in its new projection position. If good vertical registration by purely mechanical means is to be achieved the ring-gear must be stopped in exactly the right place. Conceivably this could be done (with a great deal of clatter) by dropping a mechanical dowel-pin into an accurately located hole. Such a mechanism, however, would wear out rapidly. Instead of this mechanical dowelling of the entire ring-gear, it was decided to dowel the picture

optically in position. It is for this purpose that the gear-teeth were placed on the slide carriers (Fig. 2).

The simplest form of "optical-dowelling" mechanism is the rotating plane-parallel plate. As was known from other uses of such a device an image of a moving object can be made to appear stationary. If this device could be used no matter where the ring-gear is stopped, or no matter whether it is still in motion during projection, the image can be made to appear in a fixed and stationary position; and to use it all that has to be done is to engage a pinion driving the glass plate with the gear-teeth of the film carriers (Fig. 3). By using the glass

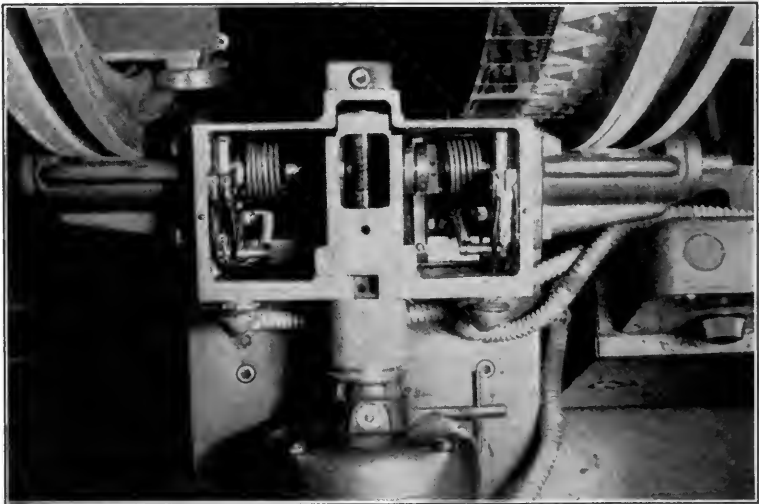

FIG. 4. Close-up of spring element and overrunning clutch, which assures accurate, rapid indexing of the drums.

plate one can afford to be $1/500$ as inaccurate in stopping the ring-gear as without the plate.

In the actual indexing operation of the drums, advantage has been taken of the fact that there are two drums and that the two are being indexed alternately. While one is moving the other is stationary. Let us consider these two drums as the two mass elements of a torsion-pendulum system. Connecting the two drums is a spring element wound up enough initially so that if one drum is held stationary when the other is released, it will swing to its stopped position (Fig. 4). Mechanically it is caught and held there by an overrunning

clutch which refuses to allow the drum to go backward. At this far position of its swing, it has stored up energy in the spring sufficient to index the other drum when it is released to its stop position, except for the frictional loss in the system. Actually, a small motor is used in the projector to keep the spring wound up, the power supplied by the motor being used to overcome the frictional losses of the system. This torsion-pendulum arrangement of the projector drums accomplishes the indexing in a very short time, gives a purely sinusoidal start and stop, is very quiet, and accurate enough in its indexing throw to bring the new pictures into such a position that the glass plate can register the images. Because of the long projection periods used, the motor that rewinds the spring is not running continuously. It starts when the spring needs power and is automatically turned off when sufficient power has been supplied.

The eleven machines as a group are electrically interlocked. Every time the left-hand drum on one machine indexes, the left-hand drums on all machines index. As soon as this indexing has taken place, the shutter mechanism starts a cross-dissolve which closes the right-hand lens and opens the left-hand lens. In general, this cross-dissolve occurs simultaneously on all projectors. However, the cross-dissolve can be made to occur in the machines in series.

THE VOCODER—ELECTRICAL RE-CREATION OF SPEECH*

HOMER DUDLEY**

Summary.—In the Bell Telephone Laboratories have been developed electrical circuits for the artificial production of speech. One form of the device is itself voice-controlled, thus differing fundamentally from the Voder of the World's Fair which is controlled by keys and pedals. It has been christened the "Vocoder" or "voice coder."

Many startling effects are possible when the code is varied, for the Vocoder then re-creates sounds quite different from those used by the person speaking. Cadences may become monotonous, rising inflections may be turned to falling inflections, a vigorous voice may become a quaver, or a single voice may accompany itself at any desired musical interval—thus converting a solo into a duet, etc. Also non-speech sounds may be coded into intelligible speech and instrumental music into vocal music.

At the World's Fairs in New York and San Francisco great interest has been shown in the speech synthesizer of the Bell System exhibits. Known as the *Voder*,¹ or Voice Operation *DE*monstrato*R*, this device creates spoken sounds and combines them into connected speech. Its raw materials are two complex tones, a hiss and a buzz; selection of one or the other and its intensity and tone quality are controlled by an operator through a keyboard.

The Voder is an off-shoot of a more extensive system, first demonstrated in an experimental stage some three years ago. That system analyzed spoken sounds, and then used the information to control the synthesizing circuit. At the time, the World's Fair displays were under consideration, so it was naturally perceived that the synthesizer, manually controlled, could be made into a dramatic demonstration. Development was for a while concentrated in that field; as a successful Voder became assured, attention was shifted back to the broader parent system. Shortly thereafter the system was named *Vocoder*^{2,3} because it operates on the principle of deriving voice codes to re-create the speech which it analyzes. The Vocoder is pictured in Fig. 1.

* Presented October 17, 1939, before a joint meeting of the Society of Motion Picture Engineers with the New York Electrical Society, at New York, N. Y.

** Bell Telephone Laboratories, New York, N. Y.

Fig. 2 shows the overall circuit for remaking speech; the analyzer is at the left and the synthesizer at the right. Electrical speech waves from a microphone are analyzed for pitch by the top channel and for spectrum by a group of channels at the bottom.

In the pitch analysis the fundamental frequency, which for simplicity will be called the pitch, is measured by a circuit containing a



FIG. 1. The Vocoder. .

frequency-discriminating network for obtaining this frequency in reasonably pure form; a frequency meter for counting, by more or less uniform pulses, the current reversals therein; and a filter for eliminating the actual speech frequencies but retaining a slowly changing current that is a direct measure of the pitch. (Unvoiced sounds, whether in whispering or the unvoiced sounds of normal speech, have insufficient power to operate the frequency meter.) The output cur-

rent of the pitch channel is then a pitch-defining signal with its current approximately proportional to the pitch of the voiced sound and equal to zero for the unvoiced sounds.

There are ten spectrum-analyzing channels,* the first handling the frequency range 0–250 cycles and the other nine, the bands, 300 cycles wide, extending from 250 cycles to 2950 cycles, a top frequency which is representative of commercial telephone circuits. Each spectrum-analyzing channel contains the proper band filter followed by a rectifier for measuring the power therein and a 25-cycle low-pass filter for retaining the current indicative of this power but eliminating any of the original speech frequencies.

The operation of the analyzer is illustrated in Fig. 3 by a group of

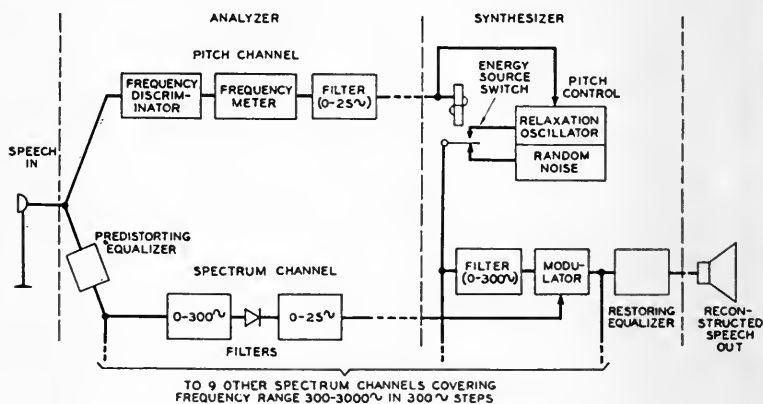

FIG. 2. Schematic arrangement of the Vocoder.

oscillograms taken in analyzing the sentence *She saw Mary*. To insure that the same speech was analyzed in obtaining the various oscillograms, the sentence was recorded on a high-quality magnetic-tape recorder with reproductions therefrom supplying current to the analyzer. The speech wave input to the analyzer is shown in the line next to the bottom, while the output is shown in the other oscillogram traces; the pitch-defining signal is at the bottom in the figure and the ten spectrum-defining signals in numerical order at the top. For convenient reference the oscillograms are lined up together, whereas in

* A 30-channel Vocoder covering the wide range of speech frequencies required for high quality has also been built and is being used as a tool in laboratory investigations.

the actual circuit the speech-defining signals lag about 17 milliseconds behind the speech input wave. The inaudible speech-defining output signals contain all the essential speech information as to the input wave, but it is to be noted that they are slow-changing and in this way correspond to lip or tongue motions, as contrasted with the higher audible vibration rates of the rapid-changing speech wave itself. The dropping of the pitch to zero for the unvoiced sounds *sh* and *s* is also readily seen.

Fig. 3 gives an idea also as to the synthesizing process. In the analyzer the speech wave is the input and the eleven speech-defining

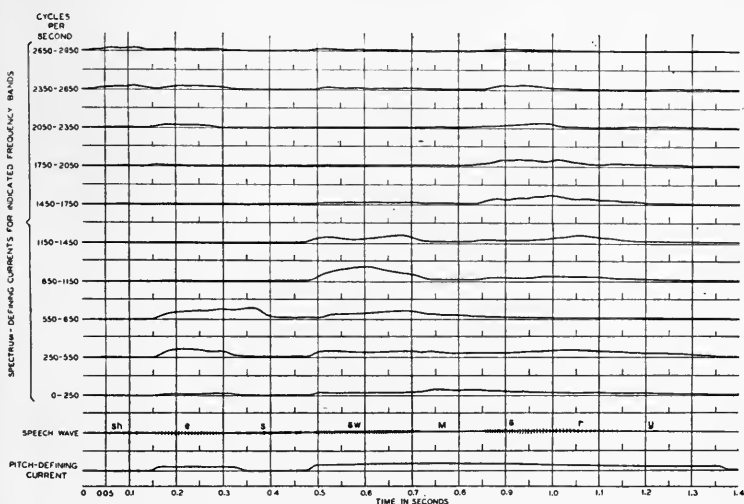

FIG. 3. The original speech wave and an analysis of its components, expressed by the variation of several direct currents.

signals are the output; in the synthesizer the eleven speech-defining signals are the input and the speech wave the output.

The steps in speech synthesis are indicated at the right of Fig. 2. The relaxation oscillator is the source of the buzz; and the random noise circuit the source of the hiss. The hiss is connected in circuit for unvoiced sounds and for quiet intervals. (In the latter case no sound output from the synthesizer results because there are no currents in the spectrum channels.) When a voiced sound is analyzed a pitch current other than zero is received with the result that the buzz is set for the correct pitch by the "pitch control" on the relaxation oscillator; and at the same time the relay marked "energy source

switch" operates, switching from the hiss source to the buzz source.

The outputs from the spectrum-analyzing channels are fed to the proper synthesizing spectrum controls with the band filters lined up to correspond. The power derived from the energy sources of the synthesizer in these various bands is then passed through modulators under the control of the spectrum-defining currents. The result is that the power output from the synthesizer is sensibly proportional in each filtered band to that measured by the analyzer in the original speech. From the loud speaker comes, then, speech approximately the same in pitch and in spectrum as the original. This synthetic speech lags the original speech by about 17 milliseconds due to the inherent delay in electrical circuits of the types used.

In the present models of the Vocoder, control switches have been introduced which permit modifications in the operation of the synthesizer. Through the manipulation of these controls interesting effects are produced. Some of the possibilities were demonstrated by the author and his associate, C. W. Vadersen, before the Society of Motion Picture Engineers and other groups. In this presentation Mr. Vadersen supplied by his own voice the incoming speech which was picked up by a microphone as shown in Fig. 2, while at the same time he manipulated the controls to produce desired effects. A remote-control switch was also provided through which, for purposes of comparison, the author could switch the microphone directly to the loud speaker and so let the audience hear how the speech would sound if it had not been modified by passing through the Vocoder.

In these demonstrations comparison is first made between direct speech and the best re-creation that the Vocoder can make. Then by manipulation of dials and switches, speech is modified in various ways. Normal speech becomes a throaty whisper when the hiss is substituted for the buzz. Although the hiss is relatively faint, it is shown to be essential for discrimination as between *church* and *shirts*.

Ordinarily the re-created pitch moves up and down with that of the original. If variation is prevented, the re-created speech is a monotone, like a chant. When the relative variation is cut in half, the voice seems flat and dragging; when the swings are twice normal, the voice seems more brilliant; when four times normal it sounds febrile, unnatural. - The controls can be reversed so that high becomes low: the tune of a song is then unrecognizable, and speech has some of the lilting characteristics of Scandinavian tongues. Another control

fixes the basic value of the re-created pitch; if this is "fluttered" by hand, the voice becomes that of an old person. By appropriate setting of the basic pitch, the voice may be anything from a low bass to a high soprano, and several amusing tricks can be performed. In one of these, the basic pitch is set to maintain a constant ratio of 5 to 4 to the original. This is a "major third" higher and harmonizes with the original. In two-part harmony, the demonstrator then sings a duet with himself. Connecting a spare synthesizer set for a 3 to 4 ratio, he then sings one part in a trio, the others being taken by his electrical doubles. Finally with the basic pitch-control, he becomes a father reprimanding his daughter; then the girl herself; and then the grandfather interceding for the youngster.

For the vocal-cord tones of the original, the Vocoder substitutes the output of a relaxation oscillator. But any sound rich in harmonics can be used: an automobile horn, an airplane roar, an organ. In some demonstrations, the sound, taken from a phonograph record, replaces the buzz and hiss inputs. Keeping careful time with the puffs of a locomotive, the demonstrator can make the locomotive puff intelligibly "We're—start—ing—slow—ly—faster, faster, faster" as the puffs come closer together. Or a church bell might be made to say "Stop—Stop—stop—don't—do—that." A particularly striking effect is that of singing with an organ to supply the tones; while the words may be spoken, the demonstrator usually sings them to hold the rhythm, but it makes no difference whether his voice is melodious or not; the tonal quality comes only from the musical source.

These demonstrations of taking a speaker's voice to pieces, measuring the pieces and then building a related new voice shows that the Vocoder has possibilities as a tool in the investigation of speech, since by its numerous controls important variables in speech can be isolated for study. As to the engineering possibilities which may grow out of the application of the principles employed in this device, it is hard to predict at the present time. The speech-defining currents, however, do have features of simplicity and inaudibility which may open the way to new types of privacy systems or to a reduction in the frequency range required for the transmission of intelligible telephonic speech.

It is obvious that this remaking of the voice is of interest in sound recording. Voice can be added to any natural or artificially produced sound. Thus the ringing of a bell may be made to convey

intelligible speech without, however, losing the distinguishing features of the notes of the bell. New voices can be made extending beyond the limitations of human voices. On the one hand uniform changes can be projected into a number of voices to give a family characteristic while on the other hand the same voice can be given an almost unlimited variety by merely adjusting control dials. The voice changes are produced consistently and automatically without effort on the part of the talker. This apparatus gives promise of ultimately bringing to the sound in the talking motion picture a degree of flexibility comparable to that already available for the picture itself to enhance its enjoyment.

REFERENCES

- ¹ DUDLEY, H., RIESZ, R. R., AND WATKINS, S. S. A.: "A Synthetic Speaker," *J. Franklin Inst.*, **CCXXVII** (June, 1939), p. 739.
- ² DUDLEY, H.: "The Automatic Synthesis of Speech," *Proc. Nat. Acad. Sci.*, **XX** (July, 1939), p. 377.
- ³ DUDLEY, H.: "Remaking Speech," *J. Acoust. Soc. Amer.*, **XI** (Oct., 1939), p. 169.

THE OBJECTIVE MEASUREMENT OF THE GRAININESS OF PHOTOGRAPHIC EMULSIONS*

A. GOETZ, W. O. GOULD, AND A. DEMBER**

Summary.—A definition of a graininess coefficient G is given by the distribution function $(2/G'\sqrt{\pi}) \int_0^x e^{-(x/G')^2} dx$ of relative transparency fluctuations $(\Delta T/T_m = x)$ in emulsions. In practical units $G = 1000G'$.

An instrument is described which measures the graininess of an emulsion sample directly in G . It consists of the graininess photometer which produces a microphotometric record in terms of x and an integrator which analyzes this record photoelectrically in terms of the probability function and indicates G . There are no standards involved in the instruments except for the geometrically defined area which scans the sample and which is simply related to G .

The G values obtained for different emulsions are described for constant density as well as the variation of G with the density. The transformation of G into G_s , the graininess effective in sound reproduction, is given as $G_s = G \cdot 10^{-D}$; furthermore, the corrections necessary for G to obtain visual graininess impressions, are discussed. The latter varies with the illumination on account of deviations from Fechner's law for certain ranges of brightness. Their visual effects are predictable from G .

The effect of scattering of the incident light within the emulsion upon the measured graininess is discussed.

The observed graininess density functions are compared with those of other authors and agreement and deviations are found where they are to be expected.

The relation between graininess and grain size is discussed with the conclusion that *a priori* no relation exists between the two qualities.

The grain distribution is found to follow, in many cases, very closely the probability function.

In a previous paper¹ the theoretical background for an objective and absolute determination of the graininess of photographic emulsions has been discussed; moreover, the fundamental design of an instrument performing graininess measurements has been given. Meanwhile a graininess meter for practical use was developed which has been in continuous operation for more than a year in a large industrial laboratory. Its construction and some of the results obtained with it shall be described henceforth.

* Received February 13, 1940.

** California Institute of Technology, Pasadena, Calif.

*Fundamental Principle.**—The objective measure of the graininess, as previously proposed, makes the following assumptions:

(a) The graininess is defined by the size and the frequency of occurrence of transparency fluctuations. This definition does not consider explicitly the average grain size but *solely* the grain distribution which for the same optical density involves the former implicitly.

(b) This frequency of occurrence of fluctuations can be adequately described in terms of the probability law (Gaussian function). The assumption of a distribution law for the occurrence of fluctuations is necessary, as without it the definition of a graininess coefficient is impossible which is *at once* descriptive of the frequency as well as of the size of transparency fluctuations.

(c) An adequate approximation to the subjective impression of graininess is given by expressing the size of the fluctuations in terms of *relative* transparency fluctuations. If T_m is the mean transparency of the emulsion and $\pm \Delta T$ the absolute size of a particular fluctuation, $\Delta T/T_m$ represents the relative size of the fluctuation which is descriptive of the subjectively realized density variation (ΔD). The approximation becomes faulty for large densities, however, graininess measurements are in general not interesting in such regions.

The above assumptions result in the following definition of the graininess coefficient G' in terms of the Gaussian function for the probability:

$$\phi = \frac{2}{G'\sqrt{\pi}} \int_0^x e^{-(x/G')^2} dx \quad \text{for} \quad x = \Delta T/T_m$$

where G' alone describes the degree of irregularity in the grain arrangement: Large values of G' thus indicate a large frequency of occurrence (probability) for large fluctuations, whereas for small values of G' the number of large fluctuations is small and that of small fluctuations is increased correspondingly. The units of G' , as defined by the equation, prove to be too large for a convenient description of the graininess actually occurring in photographic emulsions. Therefore $G = G' \cdot 10^{-3}$ is used as the practical unit.

The establishment of this coefficient requires an instrument which measures and indicates the graininess in terms of G . In principle a microphotometric record of the relative transparency fluctuations of

* For theoretical details see ref. 1.

an emulsion is taken, then this record is analyzed in terms of the probability law and the graininess coefficient is evaluated. The former operation is performed by the graininess photometer, the latter by the graininess integrator.

The Graininess Photometer.—The purpose of this instrument is to obtain a record of the relative transparency fluctuation ($\Delta T/T_m$) of a sample of a photographic emulsion. The record is produced photographically on 35-mm positive film. Each record has the length of one meter, which in turn can contain up to 10^5 fluctuations which

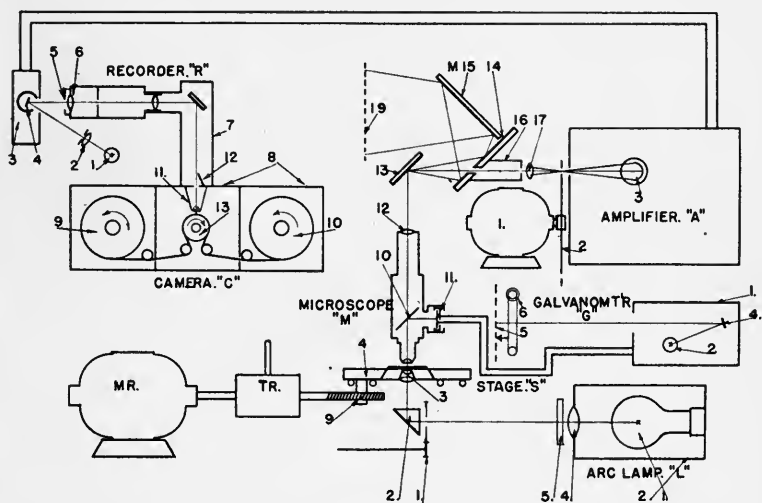

FIG. 1. Scheme of the graininess photometer: (The numbers refer to the various parts of each unit designated with a capital letter).

number represents the upper limit of the combined resolving powers of the taking as well as the recording systems.

A schematic drawing of the arrangement of the instrument is given in Fig. 1. The light-source for the microphotometric unit consists of a d-c tungsten arc lamp which is mounted adjustably in a ventilated housing. The light passes an achromatic condenser lens L_4 and a heat-absorbing filter L_5 , before entering the microscope M . Here the beam passes an iris diaphragm M_1 upon which the image of the anode of L_2 is focused. The iris M_1 is adjustable by means of a gear transmission which is led to the front panel of the instrument to K_3 . The purpose of this iris is to adjust the illumination of the

emulsion without changing the current in the arc lamp (which would result in a change of the spectral qualities of the light).

Behind the iris a 90-degree prism *M2* is mounted which deflects the light-beam into the optical axis of the microscope. The light then passes the aplanatic condenser *M3* (0.6 numerical aperture), whence it passes through the emulsion sample which is mounted upon the photometer stage *M4* into one of the two objectives *M5* or *M6* which are mounted upon a revolving nose piece. *M5* is used for the survey of the sample. It is achromatic 5 \times whereas *M6* is used for the taking of the actual record and is apochromatic 20 \times (0.65 N.A.).

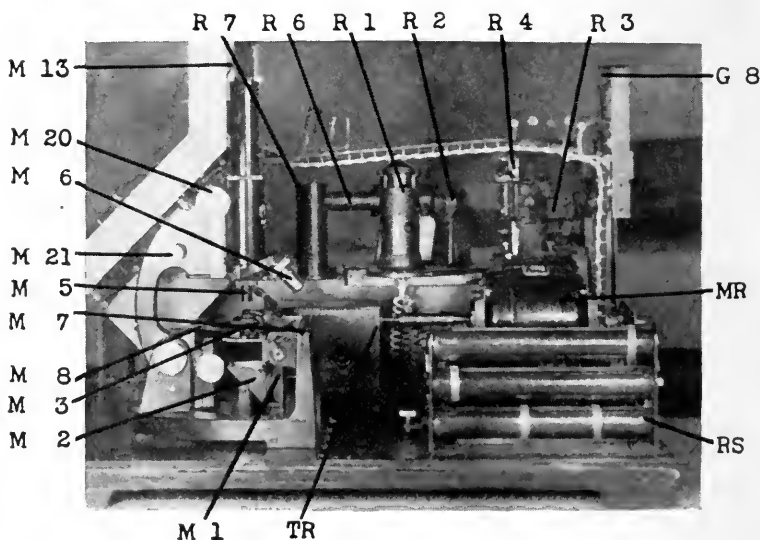

FIG. 2. Photograph of right side of graininess photometer half assembled. (The designations refer to those in Fig. 1.)

The stage which facilitates the promotion of the mounted sample during recording is supported upon the base of the microscope at three points, two of which lie in the groove *M7* (Fig. 2), the third upon a pivoted steel disk *M8*. The former supports are given by polished steel balls which roll with an interposed spacer in the groove *M7* and carry the stage *S* in a groove. The disk *M8* supports the stage at a planed surface.

The motion of the stage *S* on the base of the microscope is controlled in the following way: A micrometer spindle rests in two adjustable

bearings in the base exactly parallel to $M7$. This spindle is rotated (at 3 rpm) by a motor drive. The thread of the spindle (10 threads per cm) engages into a worm gear which rests on pivots attached to the stage. The worm gear can be clamped so that its free motion relative to the stage is arrested; consequently the stage is propelled against the base if the micrometer spindle is turned. If the clamping mechanism, however, releases the worm gear, the stage does not move as only the worm gear is turned by the spindle. The clamping mecha-

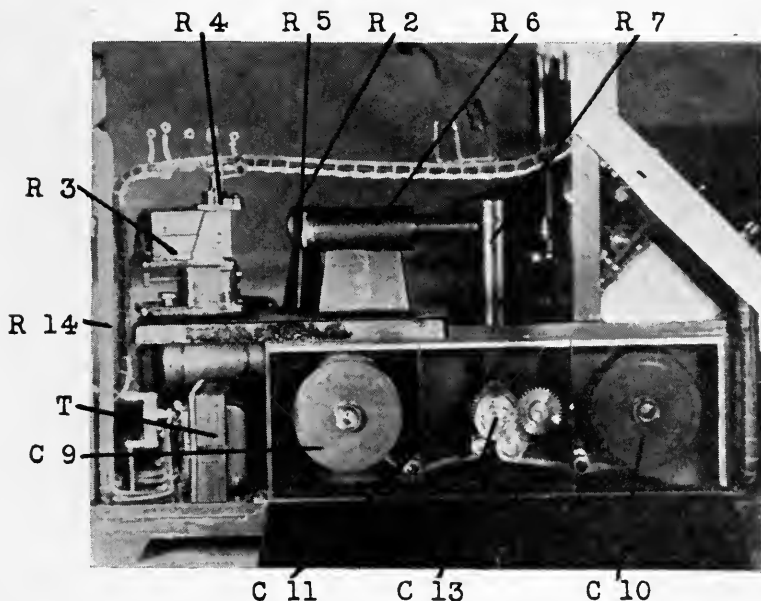

FIG. 3. Photograph of left side of graininess photometer half assembled. (The designations refer to those in Fig. 1.)

nism is operated by a flexible wire control from a push button ($Z9$, Fig. 4) on the switchboard; at the same time it controls, through two mercury switches, the motor and the recording light (see later).

The stage is driven by a resiliently mounted induction-motor which is coupled flexibly with a transmission assembly of spiral gears mounted in a box TR , coupled flexibly with the spindle $M9$ (Figs. 1 and 2).

The propelling mechanism of the stage moves the sample at a uniform speed of 3 mm per minute during recording; it is adjusted to

move the stage over exactly 1 cm which corresponds to a length of a record of slightly more than 1 meter; when the stage has travelled over this distance, the clamping device *S5* is released and the stage is pushed back, by means of a spring, into its starting position. The impact of the backward motion on the microscope is damped by a shock-absorbing device. In this way it is possible to start the motion of the stage at any position of the latter, by the engagement of the clamping mechanism, and to release it automatically, and return to the starting position, after the stage has travelled through a distance sufficient for one record.

On the upper side the stage carries an adjustable cross stage which clamps the emulsion sample and is arranged for holding of 1 × 3-inch plates. Its purpose is to facilitate the selection of a perfect region of the emulsion sample which is free from dust particles, scratches, *etc.* The sample is embedded in Nujol and mounted between thin plane glass plates.

Above the objectives *M5* or *M6* the light passes a semitransparent mirror *M10* (Fig. 1) which splits it into two beams. The reflected beam enters the barrier-layer photocell *M11* (Lange-type) whereas a fraction of the transmitted beam passes through the ocular *M12* (15×). The latter beam then enters a system of mirrors: The small mirror *M13* (Fig. 1) reflects the light horizontally upon the mirror *M14* from where the major part is reflected upon *M15* and from there upon a ground glass screen *M19* mounted into the front panel of the instrument (Fig. 4). All mirrors are first-surface mirrors (aluminum) on plate glass.

The photocell *M11* receives the light from the full optical field of the objective which is large enough to be independent of the local transparency fluctuations (graininess). The current produced by *M11* is thus the measure for the mean transparency T_m . This current is brought by a shielded cable to the mirror galvanometer (d'Arsonval-type) *G* of compact construction. Its light mark is focused upon and visible through the ground-glass screen *G5* in the front panel (Fig. 4) where accordingly an image of the pointer on *G3* appears. A travelling mark can be adjusted with *G6* for fixing the particular galvanometer deflection desired.

A fraction of the light reflected from *M13* passes through a hole drilled 45 degrees in the center of *M14*. Before it is received by the photoelectric cell *A3* (vacuum type) it is restricted by the diaphragm *M16*, the aperture of which is proportional to the "stand-

ard scanning area" α , or "standard integer" (see below). From there it passes through a short-focus lens *M17* which spreads a diffused magnified image of the section of the emulsion transmitted through *M16* upon the full cathode area of *A3*.

The purpose of this arrangement is to measure relative transparency fluctuations of a small area of the emulsion (defined by diaphragm aperture/magnification) with a photoelectric cell and to be able to check the neighborhood of the recorded area of the emulsion all the time by visual observation of *M19* (where the hole in *M14* appears as a black circle in the center of the projected image). It is thus possible

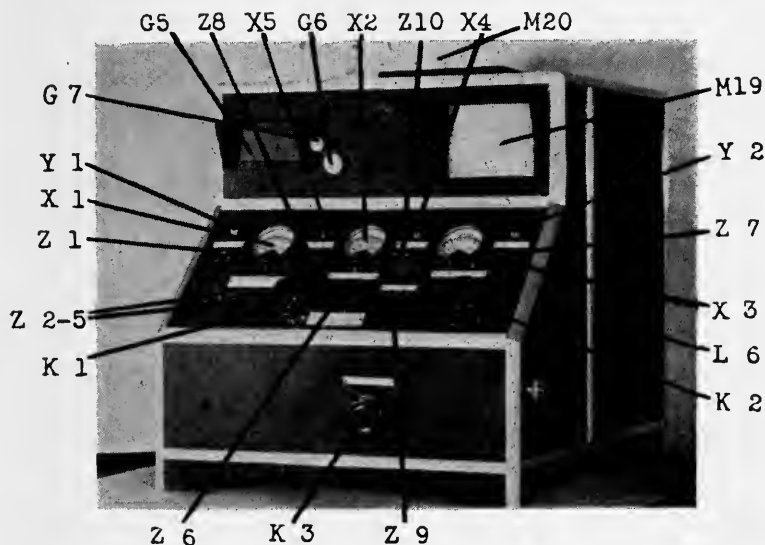

FIG. 4. Photograph of graininess photometer fully assembled.

to see whether or not accidental transparency fluctuations due to dust particles, *etc.*, lie in the path of the record.*

The power required for the recording of the relative transparency fluctuations is supplied by an amplifier *A* (Fig. 1) which is controlled

* The photometer is arranged also for use as photomicrographic apparatus for emulsions. For this use *M19* can be slid out of its position and replaced by a 9×12 -cm. photographic plate holder. As it is undesirable to have an image of the hole in *M14*, provision is made to slide *M14* into a position where the hole becomes invisible.

by the fluctuations of the photocell *A3*. In order to avoid the complications involved in a d-c amplifier the light-beam after *M17* is chopped at its focal point by a chopping disk *A2* which is driven by a small electromotor *A1*, mounted in a resilient cradle. The holes in the disk are arranged so as to produce an alternating light-beam of 860 cps, the wave-form of which is nearly square since the focal point of *M17* lies in the center of the holes.

The amplifier is of the resistance-coupled audio-frequency type and is mounted in a carefully shielded separate unit which rests upon a welded steel frame above the lamp *L* and the driving motor *MR*. The output goes into a power stage and then through a transformer into a full-wave rectifier, where the current is rectified so that a direct current of 1720 fluctuations per second results. The gain of the amplifier is controlled by a variable potentiometer resistance which is adjusted through a flexible lead from the switchboard at *K2* (Fig. 4).

This current is led into the recording galvanometer *R3* (Figs. 1 and 3), which is of the liquid-damped oscillograph type and responds to vibrations up to 1800 per second.

The optical path of the recording system is designed as follows: From the light-source *R1* the beam passes the spherical condenser *R2* which carries a slit; after reflection at the galvanometer mirror it passes through the diaphragm *R5* and the system *R6*; it is then reflected by a mirror and enters the camera vertically through a slit which can be closed by the shutter *R12*. The cylindrical objective *C11* focuses an image of *R2* upon the recording film. The width of this image is 10 microns, its length up to 20 mm. The fluctuating deflection of *R4* thus causes a variation of the length of the slit image on the recording film. The zero position of the image on the center of the film is adjustable. The record is taken on 35-mm positive cine film. The capacity of the camera is 100 feet.

The camera is loaded through the lid *C* (Figs. 1 and 3) on the left side of the instrument where the full reel *C9* supplies fresh film. This is led over the friction drive *C13* to the reel *C10* upon which the exposed film is stored. For the purpose of adjustment of the image of the recording light-beam, the shutter *R12* is provided, which prevents the exposure of the film.

C13, together with *C9* and *C10*, are driven by the motor *MR*, through the transmission *TR* through a flexible coupling which guarantees a synchronous motion of the microscope stage and the recording camera, at a rate of 1:100.

The electric power supplies are the following: 110-v a-c, 60-cycle for the motors and lights; 110-v d-c for the tungsten arc supplied by storage batteries; 270-v from dry-cells for the amplifier and photocell and 6-v from a storage-battery for the filaments. Figs. 5 and 6 are reproductions of graininess records produced by the photometer—they will be discussed later.

The Graininess Integrator.—The purpose of the graininess integrator

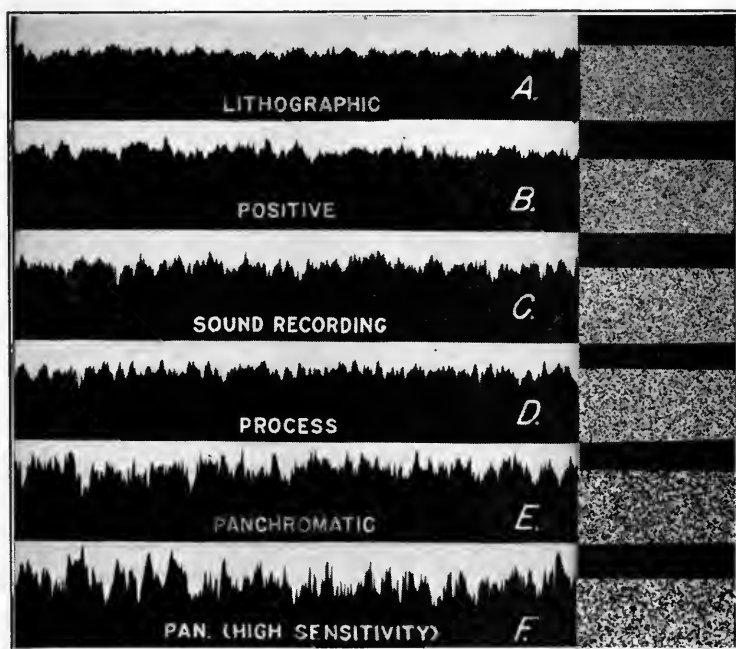

FIG. 5. Graininess records of six different emulsions of nearly equal density. On the right, photomicrographs of emulsions (300 diam.) for comparison of objective and subjective graininess.

is to analyze the graininess record of the photometer in order to determine the distribution of the relative transparency fluctuations quantitatively. This analysis requires of the integrator the measurement of the amplitude of each single fluctuation, furthermore the establishing of the frequency of occurrence of fluctuations of the same amplitude, *i. e.*, the "counting" and "assorting" of up to 100,000 ΔT 's. This statistical calculation, if performed by the customary methods, would require the labor of several days or even weeks,

whereas the integrator performs these operations photoelectrically in a few minutes with the accuracy of an extended calculation.

In principle the working of the apparatus is illustrated in Fig. 7: The drum *I* rotates about its horizontal axis *I2* and carries at its outer circumference a groove into which the record *R* is mounted.

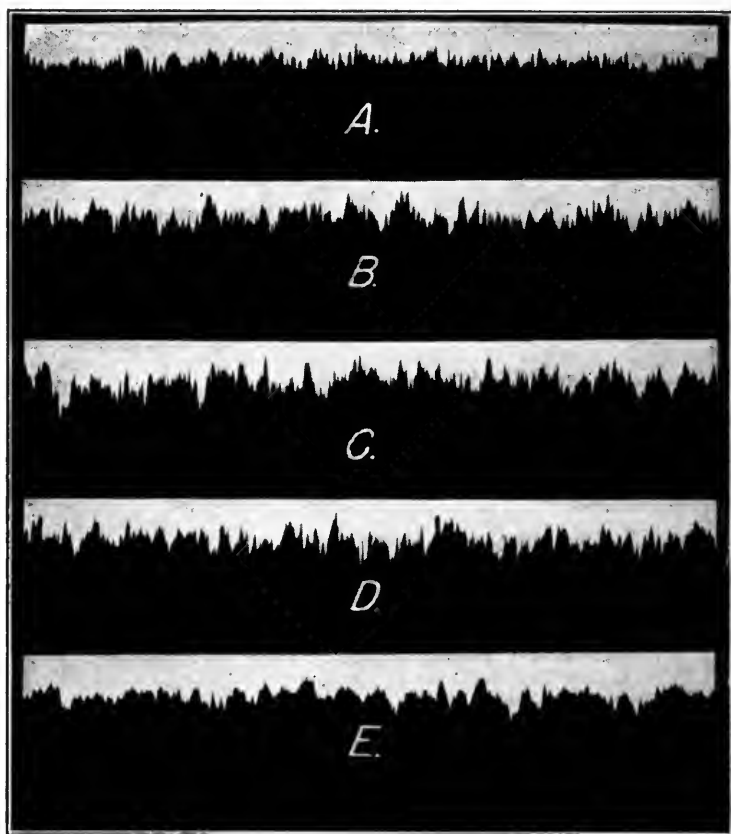

FIG. 6. Graininess records of a panchromatic emulsion for different densities.

The drum is driven by the motor *MT* through a friction drive. A small section of the record is illuminated by the projector *2*, consisting of a light-source *21*, a condenser *22*, and a slit *23*. The direction of the slit is parallel with the direction of the rotation of the record. An image of this slit is projected by the microscopic objective *24* upon

the record. The light transmitted by *R* is received by the photocell 25 built into the same frame with the projector. This frame 2 is mounted on a bed along which it can be moved normal to the direction of rotation of the record. This motion is accomplished by the attachment of 2, to the micrometer spindle 3, which is, by a number of gear transmissions (not shown in Fig. 7) connected with the dials 33 and 34.

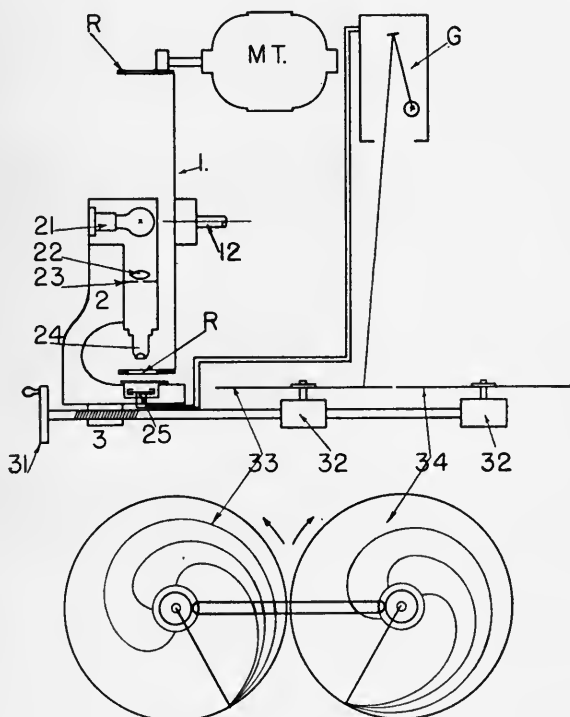

FIG. 7. Scheme of the graininess indicator. (The lower section shows a front view, on a larger scale, of the dials with three *G*-spirals on each.)

The operation of this arrangement causes the taking of an average of the recorded fluctuations for each particular position of the slit; in other words, the light transmitted to the photocell through the record corresponds to an average transparency when the drum is rotated, equivalent to the light transmitted through a slit one meter long were the record at rest. This, of course, is true only if the speed

of the drum is high, relative to the period of the indicating galvanometer.

The photocell 25 is connected with a mirror galvanometer G whose light-beam is focused upon the plane of the dials 33 and 34 which face the front of the instrument. The antiparallel motion of the dials, facilitated by the gear transmission 32, is coupled with the motion of the spindle 3, so that each position of the dials corresponds to a certain position of the slit on the record. The image of the cross-hair of the galvanometer moves thus gradually from the center of one dial to the center of the other dial when the slit moves from the black to the transparent side of the record, *i. e.*, as the photo-current goes from zero to a value corresponding to the transparency of the clear part of the record.

The dials are of semitransparent material upon which a family of spirals with numerals is drawn (Figs. 7 and 8). These spirals represent the function of the probability law drawn in polar coordinates, where the angle represents the relative transparency fluctuation, and the radius vector the frequency of occurrence. Each spiral being drawn for a different G -value represents thus the geometrical locality ("locus") of occurrence of the frequencies for a given value of G (graininess constant).

The analysis mentioned above is thus performed by moving the slit across the record and observing the resulting motion of the cross-hair on the dials: if the probability law is fulfilled, the cross-hair will be seen to "select" one of the spirals and follow it through both disks from one end to the other. The number attached to this particular spiral (*i. e.*, the G -value for which it was constructed) is the graininess coefficient of the emulsion from which the record was drawn.

The dials are mounted behind the front panel which carries a shielded slit through which the part of the former is visible which is illuminated by the light-beam of the galvanometer.

Although the operation of the instruments in principle appears to be rather involved, the taking and analyzing of graininess records is a matter of a few minutes which is a very short time compared to the labor necessary for a mathematical analysis of a record. It may be mentioned that this instrument can be applied also to the analysis of many other statistical problems.

The Standards of the Graininess Meter.—One of the most important problems in the definition of the graininess coefficient G and the development of the graininess meter is the question of the dependence of

the results on standards of the individual instrument which are *not* directly a part of the definition of G .

Aside from the undesirability of such instrument standards on account of their variation with time and wear of the meter, the unavoidable discrepancy of measurements taken with different instruments makes it highly desirable to reduce the number of individual instrument constants to a minimum. The previous description shows that they have been eliminated entirely with the sole exception of the size (α) of the "standard scanning area" (or "standard integer"*) as defined by the area of the diaphragm $M16$ in Fig. 1, which determines the size at which a given grain fluctuation will ap-

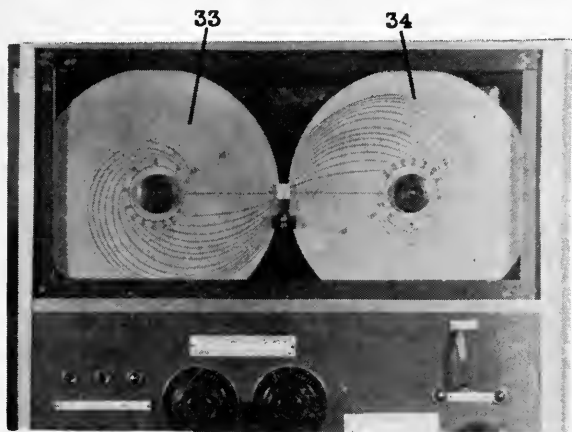

FIG. 8. Photograph of front of integrator, showing the dials. (Front panel removed.)

pear on the record. The larger α , the smaller the resolving power of the recorder—as long as the section of the sample which is determined by α is large compared with the size of a single grain.

The choice of α is practically limited toward lower sizes by the photoelectric sensitivities required which would render the instrument too delicate for practical use, and toward larger sizes by the lack of resolving power for graininess details. The area of $M16$ chosen in view of these considerations corresponds to a radius of 15 microns or an area of 0.0007 mm^2 on the emulsion.

* This "standard scanning area" should not be confused with the area of the emulsion actually scanned during the taking of a graininess record,

It must be noted that, although the G -values obtained depend on the α , they can be compared easily with values G_1 obtained with a different scanning area α_1 through the relation $G = G_1\sqrt{\alpha_1/\alpha}$.

The indications of the photometer, which depend on the sensitivity of photocells and amplifier, do not require standards as only an initial adjustment before operation is necessary, which consists in adjusting the gain of the amplifier and with it the resulting sensitivity of the recording system to a standard deflection of the galvanometer G_2 ($T_m = 1$) without interposition of a sample on the stage. This adjustment takes care of the relative sensitivity of all different elements of the photometer.

For similar reasons no standards are involved in the integrator, as the galvanometer deflections are always adjusted to the scale of the dials. The width of the integrating slit (23, Fig. 7) does not affect the evaluation of G except in that the width determines the lower limit of G accessible to measurement which is also the margin of error of all readings taken with it. As such a limit is already given by the size of α , the sensitivity of the recorder, and the imperfections of the profile on the record, the increase of the "resolving power" of the integrator does not need to exceed these limitations.

The Graininess of Different Emulsion Types.—Some of the results obtained with the graininess meter are described in the following: It has been shown previously that the graininess coefficient G was chosen in such a manner that its values can be expected to be representative of the subjective impression of inhomogeneity realized by the observer of a sufficiently enlarged section of a photographic emulsion. The subjective impression in each special case, of course, may vary with the individual observer, with the nature of the optical system used for observation, with the color of the light, etc.

Hence, for comparing the subjective effect with G , graininess records obtained from six widely different types of emulsions are shown, each being placed next to its photomicrograph of 300 diameter. This comparison requires approximately the same density of the different emulsions.

Figs. 5A to 5F represent thus reproductions of emulsions which are typical representatives of negative and positive material used for professional and amateur purposes:

(a) Material for lithographic reproductions (density: 0.46) $G = 39$.

(b) Positive film (density: 0.47) $G = 57$.

(c) Sound recording film (density: 0.50) $G = 63$.

(d) Process emulsion for purpose of reproduction (density: 0.45)
 $G = 59$.

(e) Panchromatic emulsion of medium sensitivity (density: 0.41)
 $G = 93$.

(f) Panchromatic motion picture film of very high sensitivity
(density: 0.47) $G = 105$.

The comparison of G -values shows perfect qualitative agreement with the subjective experience after which the emulsions are arranged. They demonstrate, in addition, a number of rather interesting facts at closer inspection.

From the previous description it is obvious that the smallest detail in a graininess record is equivalent to the size of a single grain, and it is interesting to find on the records that the shape of the smallest detail varies considerably with the type of emulsion inasmuch as it is of almost equal size in Fig. 5A, 5B, 5C, and is considerably larger in the last two emulsions of known large granularity (average grain size). The first three emulsions show, in spite of an approximate equal grain size, considerable variations in the size of the fluctuations, *i. e.*, in graininess. Furthermore, it appears that, apart from granularity and graininess, each emulsion possesses a rather characteristic *shape* of an average fluctuation which indicates that in different emulsions the grains group themselves in a more or less typical fashion. The fluctuations of all emulsions were found to obey the probability law sufficiently well so that the G -value is descriptive of the occurrence of *small* as well as *large* fluctuations.

Graininess and Density.—The dependence of graininess on density lies in the nature of the former: It must depend upon the density of the emulsion because the probability for the occurrence of larger fluctuations depends naturally upon the number of grains present so that one should expect a larger graininess for a larger photographic density of the same emulsion. This dependence of the graininess upon the density is demonstrated in Figs. 6A–6E, where samples of the same (panchromatic) emulsion have been analyzed for five different densities. The data resulting are the following:

Fig. 5	Density	G
(A)	0.10	58
(B)	0.25	75
(C)	0.41	93
(D)	0.67	92
(E)	1.09	114

Close inspection of the records reveals that the width of the smallest detail of the recorded pattern is (indicative of the size of the individual grain) unaffected by the density. This is not true any more for high densities (Figs. 6D and E) where the grains begin to "overlap," which fact is indicated by the occurrence of very broad fluctuations which then result in the decrease of the slope of the curve.

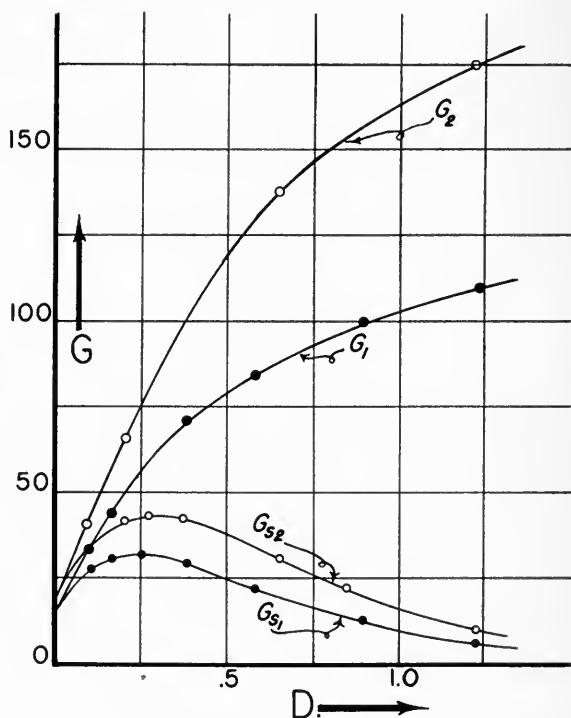

FIG. 9. G - D diagram: G_1 and G_2 are the graininess-density functions of two different emulsions from which G_{s1} and G_{s2} have been derived by transformation.

Fig. 9 represents these results in diagrammatic form where the graininess of two different emulsions is plotted (as heavily drawn curves) against the density [$G = f(D)$]. Obviously the functions are in qualitative agreement with the subjective measurements. Although one should expect $G = 0$ for $D = 0$, experience shows that considerable inhomogeneity remains in this case, partly due to the celluloid base and partly to the gelatin and the fog. The graininess

produced by these factors can be estimated, depending on the conditions, to be between 10 and 20 so that the effect of base, gelatin, and fog can produce easily 30 to 50 per cent of the graininess of fine-grain emulsions at low densities.

In order to render the graininess-density function representative of the graininess impression under various conditions, two principally different types of graininess realization must be distinguished: First, the case of *relative* transparency fluctuations ($\Delta T/T_m$) to which G refers and which are realized by determining the amplitude and frequency of the fluctuations with constant field brightness (constant *transmitted* light). Second, the case in which the *absolute* transparency fluctuations (ΔT) are realized. In this case the function $G = f(D)$ is not directly representative of the graininess impression as the transparency fluctuations are obtained by constant illumination (constant *incident* light). The graininess realized under these conditions will be called G_s as it is closely analogous to the graininess effect in sound reproduction.

Although it would be possible to use the graininess meter under the latter conditions it is not necessary to do so for the determination of G_s because the mathematical definition of G permits, by simple calculation, the transformation of $G = f(D)$ into $G_s = f_s(D)$. Since the probability function used has the simple relation between G and $(\Delta T/T_m)_a$, the average *relative* fluctuation:

$$G = (\Delta T/T_m)_a \cdot \sqrt{\pi} \quad \text{or} \quad G \cdot T_m / \sqrt{\pi} = (\Delta T)_a^\circ$$

G_s is then defined in analogy to G as:

$$G_s = (\Delta T)_a \cdot \sqrt{\pi} \quad \text{or} \quad G_s = G \cdot T_m = G \cdot 10^{-D}$$

With the aid of a transparency-density table it is thus easy to reduce a known graininess-density relation into $G_s = f_s(D)$. It is obvious that the two functions are considerably different; the difference is the larger, the larger the density; and the origin of both functions is the same as $G = G_s$ for $T = 1$ ($D = 0$).

This transformation from G to G_s results in the curves in Fig. 9. The G_s function differs mainly from the former by a maximum* at fairly low densities after which G_s declines and approaches zero for $D = \infty$. The fact that in Fig. 9 the numerical values of G_s are

* The density at which this maximum occurs depends, of course, on the shape of the G function.

smaller than G should not lead to the erroneous impression that the disturbing effect of the graininess, if realized as G_s , is *relatively* smaller than if realized under the conditions of G , because the subjective impressions received through either eye or ear are not commensurable in any case. The absolute values occurring are, of course, correctly presented by G_s , as well as by G .

The Effect of Scattering on Graininess Measurements.—The dependence of the graininess on density renders the *scattering effect* of the emulsion important. As is well known, the spatial distribution of

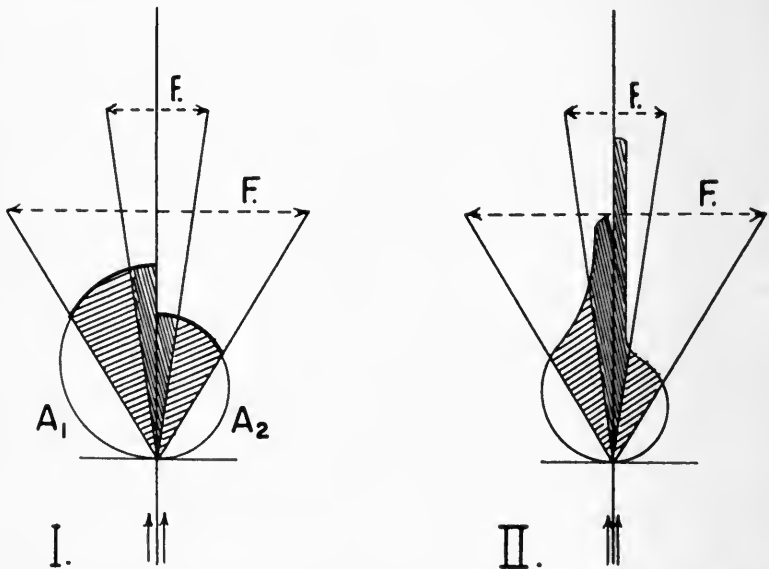

FIG. 10. A schematic demonstration of the influence of scattering upon observations with two different apertures: (I) the situation arising for a perfectly scattering emulsion; (II) for an imperfectly scattering emulsion.

the illuminating light is changed as it is diffracted and scattered on the grains while penetrating the emulsion (Callier effect). The resulting change of the light distribution is largest for parallel and least for scattered illumination for a given sample. The absolute intensity at which the fluctuations (ΔT) are realized depends, consequently, on the aperture of the receiving system in a non-proportional manner, as illustrated in Fig. 10, I and II. The former demonstrates the spatial light distribution in polar coördinates over an emulsion element illuminated with parallel light, if the former is a perfect

scatterer. The left half of I (Fig. 10) represents the conditions for a transparency twice that of the right half, as the areas of the circles which represent the total light intensity transmitted through the emulsion are related by $\sqrt{A_2/A_1}^3 = 1/2$ or $A_1/A_2 = \sqrt[3]{4}$. If this light is received by two optical systems of which one has the small aperture f , the other the large aperture F , the intensity observed through the former will be obviously smaller than in the latter, but the variation of transparency observed will in both cases be the same since the spatial distribution is the same. If the emulsion would not scatter, the difference between the intensities found at f and F would be very small; the transparency ratio observed would, however, remain the same.

If the emulsion scatters only part of the transmitted light the situation shown in Fig. 10 (II) occurs, where the left half demonstrates an emulsion of larger scattering qualities than the right half, the diffuse transparency being approximately the same for both cases. It is evident that the increase of intensity when increasing f to F is different from the former case (I) and, furthermore, differs between the left and the right half of (II). Consequently a photometric transparency measurement for a given (small) aperture can be made only for similar spatial distributions. This restriction can introduce a serious error in graininess measurements, as the spatial distribution depends not only on the grain size but also on the number of grains per unit area, *i. e.*, the transparency itself, so that in order to determine $\Delta T/T_m$ the same aperture has to be used for measuring T_m as well as ΔT , the absolute size of which is irrelevant (as long as sufficient resolving power and light-intensity are obtained). It is thus incorrect to measure, *e. g.*, the total light transmitted by a sample with a photocell at small distance (large aperture) and observe or record through an optical system at relatively small aperture. In this case the graininess values, if measured in terms of relative fluctuations, will appear too small, the more so the larger the scattering power of the emulsion.

The above description of the graininess photometer demonstrates that this difficulty is avoided inasmuch as none of the diaphragms in the scanning system decrease the aperture of it below that of the integrating system. Nevertheless, an effect occurs which is in certain respects analogous to the consequences of unequal apertures, for the experience with the graininess photometer has proved that the average amount of light received at the scanning area α (see above) and that at the integrating cell (MII , Fig. 1) is *not* proportional for different

samples if the scattering is appreciable, in spite of the same aperture of both systems. In other words, whenever the emulsion is scattering, a situation similar to Fig. 10 (*II*) arises and the average transparencies measured over the large and the small field are not commensurable.

The reason for this is probably to be found in the dissimilarity of the two light paths so that the illumination of the scanning cell is more dependent upon the parallel component of the light transmitted through the emulsion than the illumination of the integrating cell. As the two cells are balanced with each other without the interposition of a scatterer, a change of this distribution affects the light shares received by each of the systems. If thus the field brightness B in the integrating cell is kept constant ($B = 1$) the scanning cell receives an average illumination $b = B$ and the mean transparency measured here is consequently $t_m \leq T_m$. The graininess amplitudes recorded thus are $\Delta t/T_m$; if, on the other hand, the light-intensity is adjusted to a constant average brightness in the scanning system, the integrating cell receives, instead, more light and the amplitudes are measured in $(\Delta t/T_m)(B + \delta B) = \Delta t/t_m$.

The G evaluated under the latter conditions can be used directly; it represents the graininess measured in terms of the light reaching the scanning cell (*i. e.*, the more parallel light components). Correspondingly, this G -value can be reduced to the T_m value of the integrating cell as $G' = G/(B + \delta B)_m$. G' represents the more parallel transparency fluctuations in terms of a wider range of angular light components. Consequently $G' \leq G$. It is not simple to interpret the exact relationship between the two quantities. The difference between the density functions of G and G' for a panchromatic emulsion is demonstrated in Fig. 11. In all other diagrams of this paper, G has been chosen as being probably more representative for most purposes.*

This scattering effect appears to be independent of the graininess and dependent principally on grain size and grain number, and is not simply related to the measurement of the Callier quotient Q . It will be discussed in a separate paper.

Subjective and Objective Graininess.—In the introductory chapter it was stated that the graininess coefficient G is measured in terms of

* In our previous papers G' has been employed in the diagrams because the former instrument did not permit an exact comparison between t_m and T_m .

the *relative* transparency fluctuations $\Delta T/T_m$ in order to approach the logarithmic relation between stimulus and visual sensation (generally known as Fechner's law). One should thus expect that the graininess density function $G = f(D)$ should represent the subjective visual impression under all conditions of illumination of the emulsion; *i. e.*, it should be independent of the absolute value of the field brightness as well as of its variation with D .

It is, however, well known that the logarithmic relationship holds

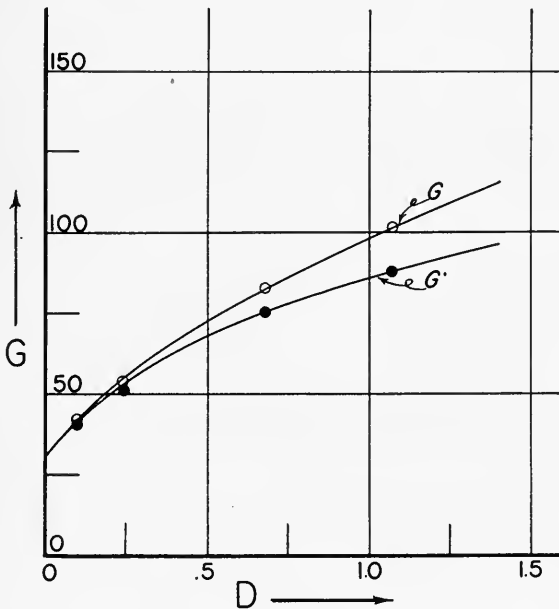

FIG. 11. G - D diagram: The two curves demonstrate the deviations in G observed on a scattering emulsion for higher densities.

only within a certain range of illumination, below and above which range considerable deviation occurs for the normal eye. As the brightness of the projection of an emulsion observed visually is frequently considerably below this range, particularly as far as regions of higher densities are concerned, it is unavoidable that deviations of the subjective visual graininess realization from the G - D function result. Furthermore, this deviation causes a dependence of the graininess impression upon the absolute brightness at which the impression

takes place, a fact which would not occur if the logarithmic sensitivity of the eye would hold over the full range of illumination used in photography. Especially the latter consequence is easily realized if one compares the graininess of the same emulsion at low and at high brightness. Due to the higher capacity for discrimination for medium brightness values, the graininess impression is considerably larger in the latter than in the former case. It is thus necessary to apply certain corrections to the $G-D$ function if the graininess is to be realized at low illuminations. These corrections can, however, be

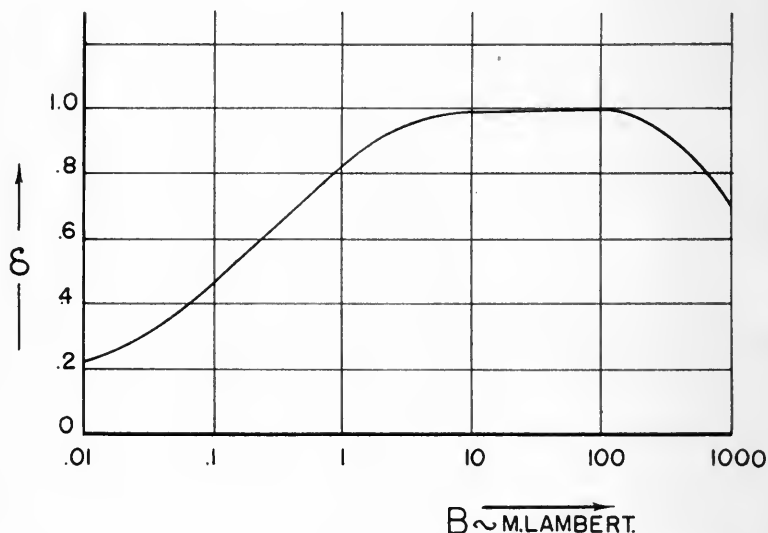

FIG. 12. δ - B diagram: The discrimination factor δ is plotted against the absolute brightness. The scale for δ is shown arbitrarily so that $\delta = 1$ for the brightness region in which Fechner's law is valid.

applied for every case in fair approximation by the following considerations.

The difference in brightness ΔB of two adjacent or alternating fields of view necessary to distinguish them visually depends upon the average brightness B at which the experiment is conducted. According to Fechner's law the relative change in brightness ($\Delta B/B$) should be the same for all light intensities. However, even under the most favorable conditions this is strictly true only in a narrow range of field brightness (10 to 100 millilamberts).² At these intensities the value of $\Delta B/B$ proves to be a minimum; therefore the visual

contrast sensitivity $B/\Delta B$ is higher in this range than at a lower or higher field brightness. Fig. 12 shows the contrast sensitivity or discrimination factor δ as a function of the field brightness $\delta = f(\log B)$ for a range sufficient to cover all actual conditions under which the graininess of emulsions may be realized. It is obviously convenient to define the discrimination factor in the brightness range for which Fechner's law ($d\delta/dB = 0$) is valid as $\delta = 1$. Consequently all other δ -values must be < 1 , $(1 - \delta)$, thus being always representative of the loss of visual discriminating power.

To obtain the values of the *visual graininess* G_v for a given brightness B , defined by the field brightness B_0 for $D = 0$ as $B = B_0 10^{-D}$, each G -value must be multiplied with the δ -value corresponding to the actual field brightness:

$$G_v = G \cdot (\delta)_B$$

This transformation is shown in Fig. 13, the upper section of which describes the dependence of δ on D for constant illumination at four different intensities ($B_0 = 1, 10, 100, 1000$ millilamberts). It is seen that a somewhat involved relation results inasmuch as δ decreases with D for low intensities, remains practically constant ($\delta = 1$) for $B_0 = 100$ millilamberts and increases for extremely large values of B_0 . The reason for the latter is due to a "blinding" effect (glare) occurring at low densities.

In the lower section of Fig. 13 the G_1 - D function of Fig. 9 is shown dashed, and each G -value has been multiplied with the δ -values for the corresponding D , resulting accordingly in four G_v functions which represent the visual graininess impression of the same emulsion for the four different intensities of (constant) illumination given above.

It follows from the previous discussion that the G - D function represents the upper limit of all G_v values. Whether the deviation of G_v from G occurs at low or at high densities is determined only by the intensity of illumination. For extremely low levels of brightness the G_v function does not even approach the G -function. Moreover, the transformation causes a change of the shape, for—depending on the shape of the particular δ - D function used—a maximum can occur for $G_v(D)$, evident in Fig. 11, for $B_0 = 1$ and 10 millilamberts.

The general shape of $\delta(D)$ determines, of course, the deviation of G_v from G . Although the seemingly best available values have been used in Figs. 12 and 13, it is not quite certain whether the function represents perfectly the physiological process involved in the realiza-

tion of the graininess, since the shape of test-objects used differed from general graininess textures. Fundamental deviations from the function used are not to be expected.

Concerning the acoustic realization of graininess by the noise

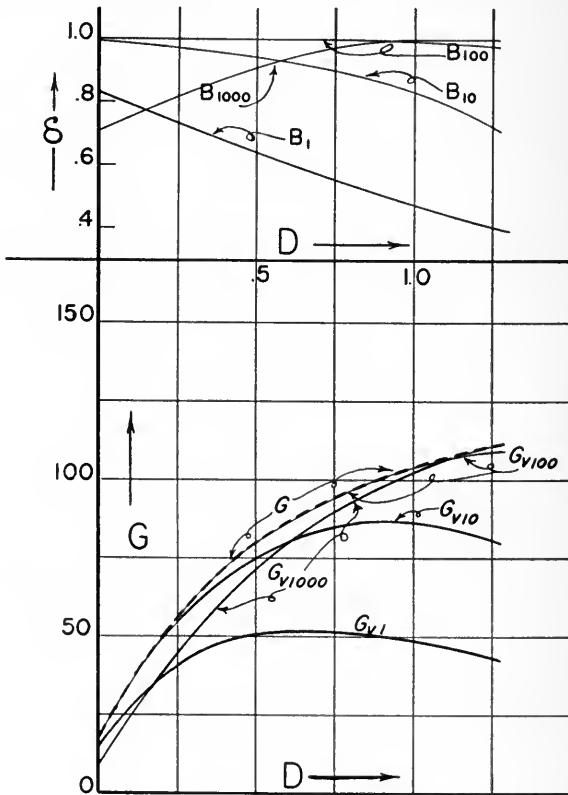

FIG. 13. The effect of field brightness upon the visually observed graininess. In the upper section δ is plotted against D for $B = 1 - 10^3$ millilambert. In the lower section the G_1 curve of Fig. 9 (dashed) is transformed with the above $\delta(D)$ into subjective graininess-density functions for different illuminations.

level, similar considerations must be made: as long as the noise level is measured with an instrument in terms of energy the G_s curve derived in Fig. 9 is representative, provided that all elements in the sound equipment are linear. If the subjective noise impression is to be represented, the G_s - D function has to be reduced in the same manner as

shown above for the visual impression, by replacing δ with the factor of acoustic discrimination (δ_s) and B with the sound intensity. The reason why, in the case of visual observation, the *relative* transparency fluctuations have to be considered, whereas the *absolute* fluctuations are representative of the graininess realized as noise, can be given as follows: For visual realization the eye adapts itself to the average brightness of the field ($\sim T_m$) and observes the fluctuations ($\sim \Delta T$) resulting in a realization in terms of $\delta \cdot \Delta T / T_m$. For sound reproductions, however, only the alternating component ($\sim (\Delta T)_a$) of the light falling upon the photocell of the amplifier will be transformed into sound energy, independent of the average light intensity ($\sim T_m$). Consequently the acoustic discrimination factor δ_s will determine the relation between the objectively measured sound energy and its subjective realization [$\sim \delta_s \cdot (\Delta T)_a$].

Comparison with Graininess Measurements of Other Observers.— Since the main practical purpose of graininess determination lies in the evaluation of a defined coefficient which is representative of the subjective impression caused by the graininess, it has been shown above what factors enter into the interpretation of G in order to render it descriptive under different conditions of observation. It is thus not out of place to compare the G - D functions obtained by other authors with those described above.

The graininess measurements so far available can be divided into 4 classes:

- (1) Subjective visual comparison with standards. (Jones and Deisch,⁴ Hardy and Jones,⁵ Crabtree,⁶ Lowry,⁷ Conklin.⁸)
- (2) Objective photometer methods. (van Kreveld and Scheffer,⁹ Siedentopf,¹⁰ Selwyn.¹¹)
- (3) Noise level. (Narath.¹²)
- (4) Caillier coefficient. (Threadgold,¹³ Eggert and collaborators,¹⁴ Narath.¹²)

The instrument developed by van Kreveld and Scheffer⁹ is in principle a microphotometer connected with an automatic device which evaluates its indications in terms of the average density fluctuations. To allow a comparison of their results, given for a numerically different unit for the graininess constant, two typical representatives of their graininess-density curves were reduced (Fig. 14) so as to coincide at $D = 0.5$ with the curve G_1 of Fig. 9. The same reduction was applied to the curve G_2 , thus permitting a fair comparison of the shapes. The agreement is obviously satisfactory for lower

densities whereas at large densities van Kreveld's curves show flat maxima.

Attempts at mathematical analysis of the density fluctuations to be expected in a photographic emulsion and its dependence on the scanning area and grain size were given by Selwyn¹¹ and Siedentopf.¹⁰ Assuming a Gaussian distribution for the density fluctuations, both authors predict a graininess-density dependence: $G \sim d\sqrt{D}$ accord-

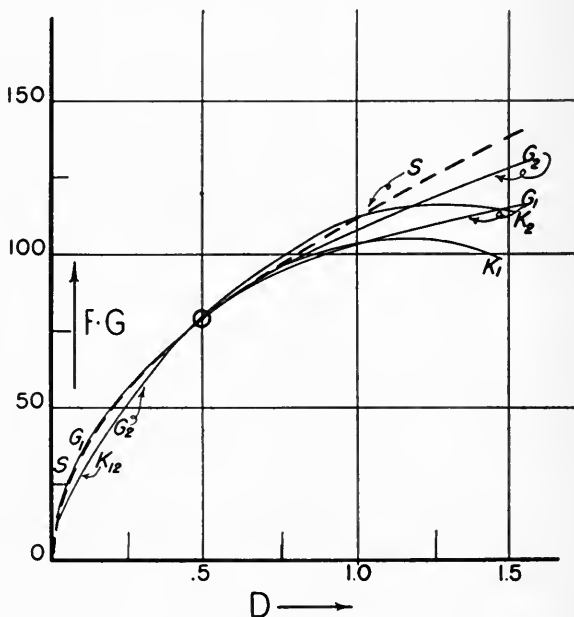

FIG. 14. Comparison of graininess-density functions obtained by different methods and observers. For commensurability all curves have been reduced to an identical G -value for $D = 0.5$. The dashed curve (S) represents the parabola $G \sim d\sqrt{D}$; K_1 , K_2 are by van Kreveld;⁹ G_1 , G_2 are identical with those in Fig. 9.

ing to which the G - D function should be parabolic for a constant average grain diameter d . (The proportionality factor depends on the units for G and the size of the scanning area.) Both authors prove by experimental data for different types of emulsions that the assumptions upon which the calculations were based are valid for the usual photographic emulsions. This parabola, coinciding at $D = 0.5$ with the experimental curves, is shown dashed in Fig. 14. Again the agreement with G_1 and G_2 is good for low and medium densities;

all experimental curves show, however, lower graininess values than predicted above $D = 1$. This deviation between all experimental curves and the parabola for high densities may have several reasons which tend to decrease the graininess for the presence of many grains; aside from this, the decrease of grain size with the density, as shown by Eggert and Kuester¹⁴ and not considered in the relation, may cause an effect in this direction.

It was stated in a previous section that for sound reproduction the average absolute transparency fluctuation measured by G_s will be indicative of the background noise. Narath finds a maximum of the noise level as function of density for $D = 0.2$, which is in good accordance with the position of the maxima of the two G_s -curves derived from the original G -curves obtained with the graininess meter.

As far as the results of the subjective methods are concerned, an instructive survey is given by Lowry, whose studies on the influence of the field brightness on the visual graininess impression are of special interest. The method consists in observing a virtual magnified image of the emulsion and measuring the magnification at which the deposit ceases to appear inhomogeneous. A halftone screen serves as standard. The observations of the graininess-density dependence at different illumination levels ($B_0 = 100, 50, 15$, and 6 millilamberts) allow a comparison with the results obtained from our graininess measurements and corrected according to the visual discrimination curve to represent the subjective impression at varying field brightnesses (Fig. 13). The general dependence of the graininess realization on density and illumination is similar, though a larger decrease at high densities is observed, resulting in a sharper maximum toward lower values of D , this effect being more pronounced at low light intensities. This can be explained by the dependence of the δ - B function (Fig. 12) upon the nature of the test-object, as pointed out before, since—as Hansen and Keck¹⁵ have stated—the discriminating capacity of the eye is not only determined by illumination and contrast, but also by the texture of the object. In this respect Conklin's⁸ comparison of the graininess of different emulsions with each other is probably the closest approach to a correct situation in this particular sense.

Graininess and Grain Size.—An entirely different principle is involved in the graininess determination by means of the Callier effect. Threadgold¹³ suggested first the use of the Callier quotient $Q = D_s/D_d =$ specular density/diffuse density, as a quantitative repre-

sentation of the "graininess"; later Eggert and his collaborators¹⁴ proposed the use of the coefficient $K = 100 \log_{10} Q$ for $D = 0.5$ for the same purpose. By means of a specially designed instrument, "the granulometer," K has been very carefully determined for a large number of emulsions in comparison with microscopic determinations of the average grain diameter d . A linear proportionality between d and K was found.

If—according to these measurements—it is taken for granted that this semi-empirical relation is truly representative of the grain diameter under all conditions, still the question arises whether the grain diameter determines the graininess. Obviously this is *not* true in the case of the positive print, as the fluctuations occurring here are largely determined by the graininess of the negative superimposed upon the graininess of the positive emulsion, without affecting the grain size of the latter. Experiments prove that the scattering power of a positive emulsion remains unchanged regardless of whether it was exposed directly or through a negative.

Since the practical interest centers chiefly upon the fluctuations occurring and not upon the grain size itself, and as, furthermore, the positive copy represents in the majority of cases the final photographic product and the actual manifestation of the graininess, measurements of this type can not replace, in general, direct determinations of fluctuation frequencies.

Less obvious is the problem when only "primary" graininess is concerned. If the graininess G represented by the frequency of transparency fluctuations could be determined by the average size d of the grain whose position relative to its neighbors fluctuates, and if one assumes the general validity of a Gaussian distribution for *all* grain arrangements occurring in emulsions, the proportionality $G \sim d$ follows only if one assumes in addition the constancy of the degree of disturbance represented by all the influences which contribute to the irregularity of the final grain arrangement.*

* An analogy with Galton's board may clarify this point: If a large number of equal sized balls, starting from one point, roll over an almost vertical plane into equidistant boxes at the lower end while the path is obstructed by pins arranged in a certain pattern, the distribution of the balls in the boxes will follow the probability function $e^{-(hx)^2}$ where $1/h$ ($= G$) determines the degree of average disturbance the balls experienced on the way to the boxes. It results in a distribution which is the broader the larger the average disturbance; the latter is determined by the arrangement of the pins and the size of the balls. The disturbing

To assume that this average disturbance of the grain is the same for all emulsions is not obvious, even though it may very well be similar for similar emulsions and similar processing.

These considerations lead to the conclusion that the use of the Callier quotient facilitates a simple and valuable method for the measurement of the grain size, but that it does not lead to a direct relationship with the actual graininess.

Graininess and Grain Distribution.—The problem of the type of distribution law valid for the grain arrangement in an emulsion has been discussed in detail previously.¹ Although there does not appear an *a priori* reason for the necessary validity of the probability law and no reliable, truly statistical method has been developed to prove this, it has generally been assumed to be true. The *G*-determination with the graininess meter is, to our knowledge, the only method which permits a precise check on the validity, for not only are a very large number of fluctuations considered in the measurement, but also the frequency for each size of fluctuation is determined in terms of the Gaussian function (by comparison of the path of the light-beam with a *G*-spiral of the integrator).

It is interesting to note that the large number of measurements on very different emulsions have shown that in many cases the probability function is an astonishingly correct description of the relation between frequency and size of fluctuations. There appear, however, to occur systematic deviations in emulsions under certain conditions, about which we intend to report separately.

The relation is generally true also for positive prints from negatives, as is to be expected, for the superposition of two (or more) truly

factor remains the same for any size of the board, balls, and pin arrangement as long as the proportions remain the same. If only the size of the balls is changed, their disturbance by the (now relatively narrower) pin arrangement is increased, resulting in a broader final distribution. Since each box determines a certain magnitude of deviation x from the average (center of the board) and the number of balls within the frequency of this deviation, and as the ball size stands for the grain diameter, the width ($\sim 1/h$) of the distribution in the boxes represents the graininess. A proportionality between *G* and *d* means the assumption of either an invariable disturbance with a linear proportionality between ball size and width of the distribution or a variation of the disturbance with the ball size in such manner that the simple above relationship occurs. The disturbance in an emulsion must be interpreted as the sum of all physico-chemical effects in the manufacturing, exposing, and processing of an emulsion which determines the grain distribution.

statistical distributions will again produce a similar distribution of a disturbance greater than that of either component. To what extent, however, this relation is quantitatively fulfilled for positives is not yet sufficiently investigated.

If one could take the strict validity of the probability relation for granted in all cases, it would be necessary only to measure an average deviation of the transparency from the mean for the determination of the graininess, as several authors have done, for a known distribution function permits the calculation of the frequency of any size of deviation from a known average size. The experience, however, that one can not rely upon the strict validity of the Gaussian distribution in an emulsion renders a type of measurement necessary which "weighs" each size of deviation against all others. There is thus the possibility of determining the frequency of fluctuations, the size of which may be particularly important for a given application of the emulsion and one can, furthermore, eliminate the effect of nonstatistical fluctuations, *e. g.*, scratches, dust particles, *etc.*, which occur in the measurement as nonsystematic deviations from the G -spirals.

CONCLUSION

The establishment of an absolute and objective graininess coefficient and the construction of an instrument which permits the measurement of this coefficient in a comparatively simple manner, renders possible the prediction of the graininess realization under different conditions of observation. Only two of these different types have been discussed—the deviation of the noise levels from the graininess density function, and the corrections for known deviations from Fechner's law with regard to the discrimination coefficient of the eye.

The problems are, of course, not the only important ones, as, for instance, the question to what extent the graininess of a negative determines the graininess of a positive made from it and the dependence on the methods of printing—the nature of the dependence of the graininess of an emulsion on its gamma—the effect of the so-called fine-grain developers upon the relation between grain size and graininess—are questions of no lesser practical importance than those described. We hope to be able to report soon on some of these questions.

In conclusion, it may be noted that progress along these lines could be furthered considerably and the results of different laboratories would be rendered comparable, once a general agreement concerning

the means and units for determining and describing this evasive quality of emulsions will be attained.

Acknowledgments.—The graininess meter was built with the aid of the Agfa Ansco Research Fund. The authors are indebted also to the directors and the staff of the Agfa Ansco Corporation, Binghamton, N. Y., and the Agfa Raw Film Corporation, Los Angeles, for technical coöperation; to C. Zeiss, Inc., for the loan of optical equipment for tests; to the RCA Manufacturing Company for the donation of two recording systems; and last but not least, to the mechanical skill of Mr. Charles Edler of this laboratory, without which the precision required in the instrument could not have been attained.

REFERENCES

¹ GOETZ, A., AND GOULD, W. O.: "The Objective Quantitative Determination of the Graininess of Photographic Emulsions," *J. Soc. Mot. Pict. Eng.*, **XXIX** (Nov., 1937), p. 510.

See also:

DEMBER, A., GOETZ, A., AND GOULD, W. O.: "The Objective Quantitative Definition of the Graininess of Photographic Emulsions," *Phys. Rev.*, **54** (1938), p. 240.

GOULD, W. O., GOETZ, A., AND DEMBER, A.: "An Instrument for the Objective and Quantitative Determination of Photographic Graininess," *Phys. Rev.*, **54** (1938), p. 240.

GOETZ, A., GOULD, W. O., AND DEMBER, A.: "An Instrument for the Absolute Measurement of the Graininess of Photographic Emulsions," *J. Soc. Mot. Pict. Eng.* **XXXIII** (Oct., 1939), p. 469.

GOETZ, A.: "Graininess of Photographic Emulsions," *Photo Technique* **1**, (Jan., 1939), p. 21.

GOULD, W. O., AND GOETZ, A.: "About the Physical Nature of the Graininess of Photographic Emulsions," *Phys. Rev.*, **56** (1939), p. 850.

² NUTTING, P. G.: "1919 Report of Standards Committee on Visual Sensitometry," *J. Opt. Soc. Amer.*, **4** (1920), p. 55.

³ TUTTLE, C.: "Densitometry and Photographic Printing. Illumination of the Negative and Its Effect upon Density," *J. Opt. Soc. Amer.*, **24** (1934), p. 272.

⁴ JONES, L. A., AND DEISCH, N.: "The Measurement of Graininess in Photographic Deposits," *J. Frank. Inst.*, **190** (1920), p. 657.

⁵ HARDY, A. C., AND JONES, L. A.: "Graininess in Motion Picture Negatives and Positives," *Trans. Soc. Mot. Pict. Eng.*, No. 14 (1922), p. 107.

⁶ CRABTREE, J. I.: "Graininess of Motion Picture Film," *Trans. Soc. Mot. Pict. Eng.*, No. 11 (1927), p. 77.

⁷ LOWRY, E. M.: "An Instrument for the Measurement of the Graininess of Photographic Materials," *J. Opt. Soc. Amer.*, **26** (1936), p. 65.

⁸ CONKLIN, O. E.: "Some Applications of the Comparison Microscope in the Film Industry," *J. Soc. Mot. Pict. Eng.*, **XVI** (Feb., 1931), p. 159.

⁹ VAN KREVELD, A.: "Objective Measurements of Graininess of Photographic Materials," *J. Opt. Soc. Amer.*, **26** (1936), p. 170.

VAN KREVELD, A., AND SCHEFFER, J. C.: "Graininess of Photographic Materials in Objective Absolute Measure," *J. Opt. Soc. Amer.*, **27** (1937), p. 100.

¹⁰ SIEDENTOPF, H.: "Ueber Körnigkeit, Dichteschwankungen und Vergrößerungsfähigkeit photographischer Negative," *Phys. Zeitschr.*, **38** (1937), p. 454.

¹¹ SELWYN, E. W. H.: "A Theory of Graininess," *Phot. J.*, **75** (1935), p. 571.

SELWYN, E. W. H.: "Experiments on the Nature of Graininess," *Phot. J.*, **79** (1939), p. 513.

¹² NARATH, A.: "Ueber die Körnigkeit photographischer Schichten," *Kino-technik*, **16** (1934), pp. 255, 287.

¹³ THREADGOLD, S. D.: "The Measurement of Graininess," *Phot. J.*, **72** (1932), p. 348.

THREADGOLD, S. D.: "The Callier Coefficient and Its Relation to Graininess," *Phot. J.*, **79** (1939), p. 524.

¹⁴ KÜSTER, A.: "Ueber die Körnigkeit und das Auflösungsvermögen photographischer Schichten," *Veröff. Agfa*, **3** (1933), p. 93.

EGGERT, J., AND KÜSTER, A.: "Callierquotient and mittlerer Korndurchmesser entwickelter photographischer Schichten," *Veröff. Agfa*, **4** (1935), p. 49.

BRANDES, H.: "Apparate zur Messung der Körnigkeit entwickelter photographischer Schichten," *Veröff. Agfa*, **4** (1935), p. 58.

EGGERT, J., AND KÜSTER, A.: "Statistische Versuche zur Beziehung zwischen Callier-Quotient, Körnigkeit und Grenzvergrößerung," *Veröff. Agfa*, **6** (1939), p. 186.

¹⁵ HANSEN, G., AND KECK, P. H.: "Messungen der Körnigkeit an Negativschichten," *Zeitschr. f. wiss. Phot.*, **37** (1938), pp. 86, 99.

REGULATIONS OF THE NATIONAL BOARD OF FIRE UNDERWRITERS

FOR THE

STORAGE AND HANDLING OF NITROCELLULOSE MOTION PICTURE FILM

AS RECOMMENDED BY THE

NATIONAL FIRE PROTECTION ASSOCIATION

(These regulations are published herein for information and ready reference by the readers of the Journal. Publication in the Journal is therefore in no way related to approval or disapproval of these regulations by the Society, although much of the material relating to motion picture projection rooms has been based upon recommendations made by the Sub-Committee on Fire Hazards of the SMPE Projection Practice Committee, published in the November, 1938, issue of the Journal.)

The following regulations are reprinted from NBFU Pamphlet No. 40, July 1, 1939, copies of which may be obtained from the National Board of Fire Underwriters, New York, N. Y.)

- (1) Application of Rules
- (2) Scope of Regulations
- (3) Arrangement of Regulations
- (4) Approval of Plans
- (5) Definitions

Part I. General Provisions Regarding the Storage and Handling of Film

- (11) Construction and Arrangement of Buildings
- (12) Electrical Equipment
- (13) Heating Equipment
- (14) Sprinklers and Other Fire Protection Appliances
- (15) Storage of Film
- (16) Film Cabinets
- (17) Film Vaults
- (18) Handling of Film
- (19) Motion Picture Projection and Special Processes

Part II. Special Provisions for Special Occupancies

- (21) Motion Picture Theaters and Other Occupancies in which the Principal Use of Film Is in Motion Picture Projection

- (22) Motion Picture Film Exchanges
- (23) Motion Picture Film Laboratories
- (24) Motion Picture Studios

(1) *Application of Rules.*—These regulations are intended to apply to the storage and handling of nitrocellulose motion picture film, in all places except establishments manufacturing such film and storage incident thereto. They are not intended to apply to the storage and handling of film having a cellulose acetate or other approved slow-burning base nor to photographic and X-ray film. (See separate regulations on *Photographic and X-ray Film.*)

(2) *Scope of Regulations.*—(a) These regulations are intended to provide reasonable provisions for the storage and handling of motion picture film, based on minimum requirements for safety to life and property from fire.

(b) It is strongly recommended that film exchanges, laboratories, and studios be permitted only in sprinklered buildings of fireproof* construction. In buildings of non-fireproof construction which have been adapted to such occupancies, automatic sprinklers should be installed as hereinafter specified and suitable fire cut-offs provided between each room in which film is handled or stored and other sections of the building, and adequate exit facilities provided. Suitable requirements will be found in the Recommended Building Code of the National Board of Fire Underwriters.

(3) *Arrangement of Regulations.*—(a) These regulations are divided into two parts: Part I gives general provisions regarding the storage and handling of film; Part II gives special provisions for special occupancies as motion picture theaters, exchanges, laboratories, and studios, which apply in addition to any and all of the general provisions which may also be applicable.

(b) The grouping of the special provisions under the heading of special occupancies is merely for convenience in the application of these regulations. Any particular process or operation in any type of occupancy shall be governed by the provisions given for that process or operation, whether under the heading of that occupancy or any other heading, unless otherwise specifically provided herein.

* The term "fireproof" is used as defined in the *Building Code of the National Board of Fire Underwriters* and as having in these regulations the same meaning as the term "fire-resistive" as used by the National Fire Protection Association.

For example, any process in a studio which, from the standpoint of the authority enforcing these regulations, partakes of the same nature as some process covered under laboratories, shall be governed by the provisions for that process given under laboratories.

(4) *Approval of Plans.*—Before constructing any building for use as a motion picture film occupancy, or remodeling any building for such occupancy, or building any film vault, or installing any enclosure for motion picture projection, or installing any screening room, complete plans of such proposed construction or installation should be submitted to the inspection department having jurisdiction for approval. These plans shall show in detail all proposed construction and structural changes and the means of protection to be provided, the heating system with the protection for it, the electrical equipment, and the character and location of exposures.

(5) *Definitions.*—Whenever used in these regulations the following words shall be construed as having the meanings given below.

(a) "Film" or "motion picture film," motion picture or sound recording film having a nitrocellulose base, whether in the form of unexposed film, positives, negatives, scrap, or used film.

(b) "Vault," a vault constructed and equipped in accordance with the requirements of Section 17.

(c) "Cabinet," a cabinet constructed and equipped in accordance with the requirements of Section 16.

(d) "Standard roll," a roll of film $1\frac{3}{8}$ inches (35 mm) wide and 1000 feet long, weighing approximately 5 pounds, used as a unit in calculating the weight of film.

NOTE.—This definition is intended to establish a measure of length and weight and is not designed to prohibit the use of double rolls (2000 feet) of film in theaters and exchanges.

(e) "Partition," except where some other form of construction is specified, a partition constructed in accordance with the specifications given in sub-section 112.

PART I. GENERAL PROVISIONS REGARDING THE STORAGE AND HANDLING OF MOTION PICTURE FILM

Section 11.—Construction and Arrangement of Buildings

(111) Motion picture film should preferably be stored or handled only in buildings of fireproof construction.

(112) *Partitions*.—(a) All rooms in which motion picture film is stored or handled, except motion picture projection rooms and film vaults, shall be separated from each other and from all other parts of the building by partitions of suitable stability and having a fire retardant classification of not less than 1 hour as determined by the Standard Fire Test. Partitions constructed as follows shall be deemed to have the required fire retardant classification:

(1) Hollow clay tile laid in cement mortar, cement lime mortar, or gypsum mortar, not less than 4 inches thick and plastered on both sides with not less than $\frac{1}{2}$ inch of gypsum mortar or cement mortar;

(2) Gypsum blocks, either solid or hollow, laid in gypsum mortar, not less than 3 inches thick and plastered on both sides with not less than $\frac{1}{2}$ inch of gypsum mortar;

(3) Metal lath supported by incombustible studs, plastered on both sides to fully cover the metal lath and studs with not less than $\frac{3}{4}$ inch of gypsum mortar or cement mortar and having a total thickness of not less than $2\frac{1}{2}$ inches;

(4) Wood studs covered both sides with metal lath and $\frac{3}{4}$ inch gypsum mortar or cement mortar, and having a total thickness of not less than $5\frac{1}{4}$ inches. (This type of construction to be used only in buildings not of fireproof construction.)

(b) Partitions shall be continuous from floor to ceiling and securely anchored to walls, floor, and ceiling.

(c) Openings in partitions shall be protected by approved fire doors of a type suitable for use in Class C situations as defined in the *Regulations for the Protection of Openings in Walls and Partitions against Fire*.

(113) In buildings not of fireproof construction, all rooms in which motion picture film is stored or handled shall have floors and ceilings of at least double $\frac{7}{8}$ -inch tongue and groove boards, or the equivalent.

(114) *Exits*.—It is essential that all rooms in which film is handled be provided with adequate aisle space and safe means of egress. Aisle space should not be less than 30 inches clear wherever walking is necessary. Rooms in which film is handled and in which more than two persons work shall have two or more exits, remote from each other. Every exit shall be marked "Exit" in letters not less than 6 inches high, or by an illuminated sign with letters of the same height.

(115) *Vents*.—All new buildings erected to be used for film occupancy, and all existing buildings remodeled for such occupancy, except projection rooms (sub-section 191), rewind rooms (paragraph

212), and rooms associated therewith (paragraph 213(a)4), shall be provided in every room where film is stored or handled, with vents that will open automatically in case of fire. These should be of ample size; they may be in the form of automatic skylights or automatic-opening window sash. All rooms in which film is stored or handled in existing buildings shall be provided with such vents wherever practicable.

(116) *Spacing of Workers.*—A feature which often contributes materially to the hazard to life in film handling rooms is the congestion of workers together with large quantities of film. To prevent such congestion of workers and the attendant hazard to life, the number of persons working in a room where film is handled should never be more than will result in a ratio of floor area to number of workers, less than 35 square feet per person. Not over 15 persons shall work at one time in any one room (not including the stage of motion picture studios) in which film is handled.

(117) *Tables and Racks.*—Tables and racks used in connection with the handling of film (joining, inspection, and assembling tables, for example) shall be of metal or other non-combustible material. They should be kept at least 4 inches away from any radiator or heating apparatus. Tables shall not be provided with racks or shelves underneath them, which might be used for keeping film or other materials.

Section 12.—Electrical Equipment

(121) Artificial illumination in any room where film is handled or stored shall be restricted to incandescent electric lights, except that arc lights or other forms of electric lights may be used in studios.

(122) All electrical wiring and equipment shall conform to the *National Electrical Code*. The wiring method shall be rigid metal conduit or other approved type of metal raceway. Fuses shall be enclosed.

(123) Light fixtures shall be firmly fixed in place, and lights shall be protected by vapor-tight globes. All lights shall be equipped with keyless sockets and operated by wall switches.

(124) Light boxes reading "EXIT" in letters not less than six inches in height shall be placed at the exits of all darkrooms.

(125) Portable electric lights on extension cords shall not be used in any room in which film is handled or stored, other than the stage of motion picture studios, except that in emergency such portable lamps may be used if equipped with approved keyless sockets and metal

protective lamp guards, and having rubber-covered cords of the Hard Service (type *S*) or Junior Hard Service (type *SJ*) varieties, with suitable locking plugs.

(126) Motors shall be of the non-sparking type, or shall be of an enclosed type, so arranged as to minimize the danger of sparks.

(127) Motion picture projectors and other associated electrical equipment shall be of approved type and safeguarded in accordance with the requirements of the *National Electrical Code*.

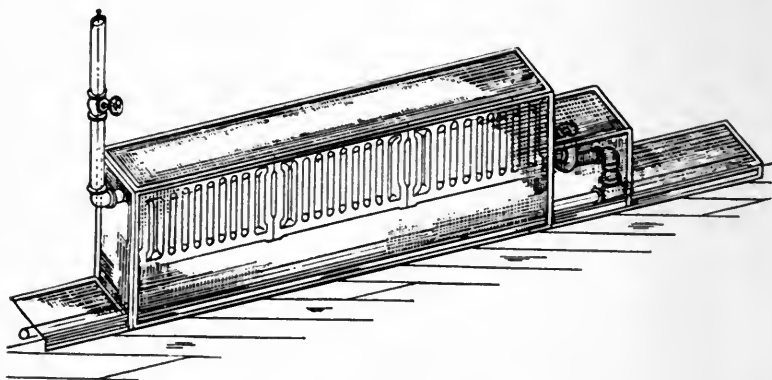

FIG. 1.

FIGS. 1 AND 2. Method of Guarding Radiators.

Guard of $\frac{1}{4}$ -inch mesh galvanized steel wire cloth 20 gauge. Bottom hinged to lift up for cleaning purposes. Top slopes so articles placed thereon will slide off. The top therefore can not be used as a shelf.

Section 13.—Heating Equipment

(131) Artificial heating in any building or room, other than a vault, in which motion picture film is used, handled, or stored, shall be restricted to steam not exceeding 15 pounds' pressure or hot water, provided, however, that this shall not be construed as prohibiting the installation of an indirect system employing high pressure steam when the radiators or heating coils of such system are not located in the room or rooms to be heated. Heat generating apparatus shall be in a separate room.

NOTE.—Ordinary hot air furnaces are prohibited. Gas, oil, and electric heaters are prohibited in rooms where film is handled or stored.

(132) All steam pipes within 6 feet of the floor, and where passing through partitions or racks or near woodwork, shall be covered with

approved pipe covering. All radiators, heating coils, and pipes and returns that are near the floor or are so located as to permit any combustible material, waste or dirt to come in contact therewith shall be guarded and protected by means of $\frac{1}{4}$ -inch mesh galvanized steel wire cloth No. 20 B. & S. gauge, or by its equivalent. The bottoms of such guards shall be arranged so as to lift up for cleaning purposes and the tops to slope so that guards can not be used as shelves. Guards shall be so constructed that no film can come within 4 inches of the heating surface, and shall be made with a substantial metal framework which will prevent the wire mesh being forced against the radiator or pipes.

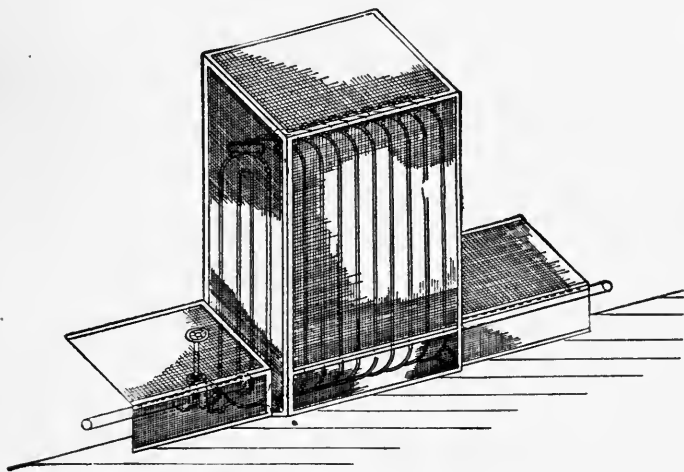

FIG. 2.

(133) Air conditioning, warm air heating, air cooling, and ventilating systems employing ducts shall be installed in accordance with the *Regulations on Air Conditioning, Warm Air Heating, Air Cooling, and Ventilating Systems*. In addition to the fire dampers required by said regulations, approved automatic fire dampers shall also be located at such points as may be necessary so that, as far as the duct system is concerned, each room in which film is handled is cut off by dampers from every other room, including those where film is handled as well as those where film is not handled. (See Par. 191(g) regarding ventilation of projection rooms.) Any system used for air conditioning a film vault shall be entirely independent, with no duct connecting to any other vault or room.

Section 14.—Sprinklers and Other Fire Protection Appliances

NOTE.—See sub-section 175 regarding sprinklers in film vaults.

(141) Every room in which film is stored or handled in quantities greater than 50 pounds (10 standard rolls), except in motion picture projection booths or rooms and rewinding rooms connected therewith, shall be equipped with an approved system of automatic sprinklers. Buildings or sections of buildings used as exchanges, laboratories, or studios shall be equipped with automatic sprinklers, as provided under sub-sections 221, 231, and 241. All buildings used for the storage or handling of film should be completely equipped with automatic sprinklers.

(142) The spacing of sprinkler heads in all sections where film is handled shall not exceed one head for each 64 square feet, with heads and lines not over 8 feet apart; provided, that in the stage section of motion picture studios the spacing of sprinklers shall not exceed one head for each 80 square feet. In existing buildings where the spacing of sprinkler heads exceeds that specified above, the inspection department having jurisdiction may require the installation of additional heads wherever the hazard of some machine, process, or accumulation of film warrants such protection.

(143) (a) Water supply shall be provided acceptable to the inspection department having jurisdiction.

(b) Water supplies for automatic sprinklers shall be based on an estimate of 20 gallons a minute per head for 20 minutes for the total number of heads in one vault, plus 25% of the number of heads in the largest fire area. (A fire area is regarded as an area cut off by brick or concrete walls having a minimum thickness of 8 inches. Each opening in these walls to be protected by one self-closing fire door, Class A type.)

(144) Every room in which film is stored or handled, except film vaults, shall be provided with first aid fire appliances of types using water or water solutions.

NOTE.—Small hose equipment is recommended, and the following types of extinguishers are considered suitable: soda acid, calcium chloride, pump tank, and loaded stream.

See *Regulations on First Aid Fire Appliances, and Standpipe and Hose Systems.*

Section 15.—Storage of Film

(151) The storage of motion picture film, not in process or being

worked upon, and except as hereinafter specifically provided shall be in accordance with the following rules:

(a) Except as provided in paragraph (b)—

(1) Amounts in excess of 25 pounds (5 standard rolls) but not in excess of 1000 pounds (200 standard rolls) shall be kept in approved cabinets if not in vaults;

(2) Amounts in excess of 1000 pounds shall be kept in vaults;

(3) Storage for any considerable length of time should be in vaults only.

(b) Unexposed film enclosed in the original shipping cases, conforming to I. C. C. regulations with each roll in a separate container, shall be kept in a sprinklered room, and if over 5 cases aggregating in excess of 750 pounds (150 standard rolls) shall be kept in a sprinklered room used for no other purpose.

(152) Valuable negatives shall be stored in vaults used only for such film, in suitable heat-insulating containers designed to minimize water damage.

NOTE.—The above paragraph being principally concerned with safeguarding values would not need to be inserted in an ordinance.

Section 16.—Film Cabinets

(161) *Construction.*—(a) Cabinets including doors shall be of a type of construction approved by the inspection department having jurisdiction.

NOTE.—Cabinets may be of approved metal construction, or may be built into the building with a type of construction listed under partitions, sub-section 112 (a) 1, 2, or 3, if otherwise conforming to the provisions of this section.

(b) Cabinets shall have a capacity of not in excess of 375 pounds of film (75 standard rolls).

(c) Racks in the cabinet shall be of metal and so arranged that containers will be stored on edge only.

(d) Doors shall close tightly against the jambs, and should be so arranged as to remain normally closed and latched.

(162) *Vents.*—(a) Cabinets having a capacity of over 50 pounds of film (10 standard rolls) shall be provided with a vent from each compartment to the outside of the building. The vent shall have a minimum effective sectional area of 14 square inches per 100 pounds

of film capacity. For long lengths of vent pipe a larger size may be necessary to take care of friction loss and turns in the pipe.

(b) Vent flues shall be of construction equivalent to 18 U. S. gauge riveted sheet metal, and where inside the building shall be covered with 1 inch of approved heat insulating material.

(163) *Sprinklers.*—(a) Cabinets holding over 75 pounds of film (15 standard rolls) shall be provided with at least one automatic sprinkler; provided, however, that a cabinet constructed so that each roll is in a separate compartment and will burn out without communicating fire to film in any other compartment, need not be provided with an automatic sprinkler.

(b) Cabinets of not over 125 pounds' capacity for use in projection booths and rewinding rooms only, may have the required sprinkler head connected to the house supply by not less than $\frac{3}{4}$ -inch pipe, provided the water pressure at that elevation be not less than 15 pounds, and is sufficient to supply not less than 15 gallons a minute.

(164) Film in cabinets shall be in individual roll containers or in I. C. C. shipping containers. Materials other than film shall not be stored in the same cabinet with film.

Section 17—Film Vaults

(171) *Construction.*—(a) Vaults shall be constructed in accordance with plans submitted to and approved by the inspection department having jurisdiction.

(b) Vaults shall not exceed 750 cubic feet in inside dimensions.

(c) Walls and floor shall be constructed of not less than 8 inches of brick, 6 inches of reinforced concrete, or of 12 inches of hollow tile plastered on both sides with cement plaster to a thickness of at least $\frac{1}{2}$ inch; they shall be without cracks or holes permitting escape of gases of combustion into the building.

(d) Vaults shall be supported by masonry or steel of sufficient strength to carry the load safely. Beams shall rest at both ends on steel girders, iron or steel columns, or walls or piers of masonry. The supports shall afford at least 4 hours' protection as determined by the Standard Fire Test. Hollow tile shall not be used for foundation walls or for walls of other than the top vault where vaults are superimposed.

(e) The roof shall be of reinforced concrete at least 6 inches thick; where the floor or roof above is equivalent to this, it may serve as the vault roof; a heavy wire screen of not less than 2-inch mesh, or its

equivalent, may be installed below the required roof to limit the interior vault space to 750 cubic feet.

(f) Vaults shall be provided with suitable drains or scuppers to the outside of the building.

(g) Proximity to stacks and other sources of heat shall be avoided.

(172) *Doors.*—Door openings shall be protected with approved fire doors, one on each face of the wall.

NOTE.—Vaults may have two door openings. Such an arrangement is often a great convenience, as in laboratories, where the vault is located between rooms and used for the temporary storage of film in process.

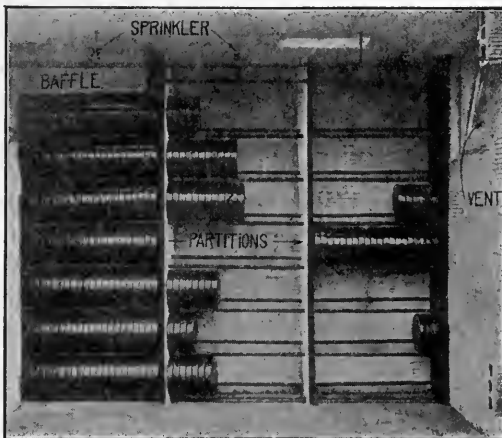

FIG. 3. Film storage vault. Showing construction of racks and installation of partitions, baffles, and sprinklers.

Doors shall be of the type suitable for use in Class *B* situations as defined in the *Regulations for the Protection of Openings in Walls and Partitions against Fire*. The interior door shall be automatic. The outer door shall be of the swinging type and close into an approved frame or otherwise made tight to prevent the passage of flame around the edges. It shall be self-closing, and if fastened open shall be arranged to close automatically in case of fire originating in or out of the vault. Approved quick-operating devices for closing vault doors are recognized as having advantages over the fusible link, and their use is recommended.

(173) *Vents.*—(a) Each vault shall be provided with an indepen-

dent vent having a minimum effective sectional area of 140 square inches per 1000 pounds of film capacity (equivalent to 70 square inches per 100 standard rolls). The vent area for a vault of 750 cubic feet shall be not less than 1400 square inches.

NOTE.—In determining the proper vent opening, allowance must be made for the window frame and sash, for the area of the glass is considered the effective sectional area of the vent opening.

(b) Vent flues inside the building shall be constructed of 5 inches of reinforced concrete or of a construction equivalent to that required for smoke chimneys. Exterior flues shall be of a construction equivalent to that of smoke stacks.

(c) The outlet of each vent shall be above roof or shall be made to face street, court, or other clear opening which will give a distance of at least 50 feet to any window or other opening exposed thereby and not in the same plane, and a distance of at least 25 feet to any fire escape on the same or higher level.

(d) Vaults, especially those having a vent in the form of a window, shall be arranged in some manner which will protect the film in the vault against ignition by—

(1) Rays of the sun, whenever the film in the vault is exposed to direct rays of the sun entering through the vent. This may be done by painting the glass in the vent opening a dark color;

(2) Radiated heat entering through the vent opening, as from an exposure fire, whenever the vent is severely exposed by buildings or storage of combustible material, or by other openings in the same wall.

NOTE.—To effect the above protection, one method which has been used employs two baffle walls inside the vault. The baffle wall nearer the vent should extend from the ceiling down to within about 3 feet of the floor, and the inner baffle wall from the floor up to within about 3 feet of the ceiling. Baffle walls should be of substantial construction and should be so spaced and arranged as to afford the full required vent area from the film storage space to the outside.

(e) Each vent shall be protected against the weather by single thickness glass ($\frac{1}{16}$ inch thick), in a sash arranged to open automatically in case of fire by the means of an approved releasing device placed inside the vault. The use of approved quick-operating devices is recommended. The area of the glass shall be the effective sectional area of the vent opening. No pane of glass shall be smaller than 200 square inches. Any protection equivalent to the above may be accepted in lieu thereof.

(f) A light wire screen not coarser than $1/8$ inch mesh shall be placed in each vent. Bars or screen designed to prevent burglary or injury to contents shall not have a mesh of less than 4 inches, shall be located inside the light wire screen, and shall give a net opening equal to that called for in (a). Bars and screens shall be so arranged as not to interfere with the automatic operation of the sash.

(g) Film vaults shall not be provided with skylights or glass windows other than as specified for vents.

(174) *Racks*.—Racks in film vaults shall be of metal or other incombustible material and arranged for the storage of single reel containers on edge or for I. C. C. shipping containers. Negatives need not be stored on edge. Vertical incombustible partitions equivalent in durability and heat insulation to $3/8$ -inch hard asbestos

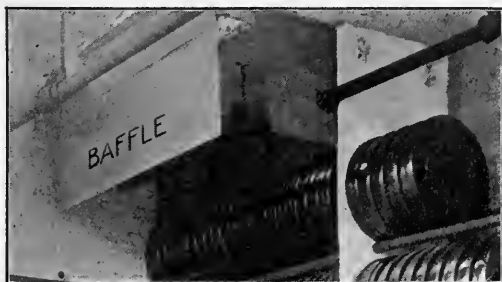

FIG. 4. View of baffles and partitions in connection with sprinklers.

and extending from floor to top of rack shall be provided to divide racks into sections not over 3 feet wide and so placed as not to obstruct distribution from sprinkler heads. Racks shall not obstruct vent openings.

(175) *Sprinklers*.—Vaults shall be protected by an approved system of automatic sprinklers, with a ratio of one head to each $62\frac{1}{2}$ cubic feet of total vault space. A vault of 750 cubic feet shall have 12 sprinkler heads. Sprinkler heads shall be arranged to give uniform distribution within the sections formed by the above mentioned partitions. They shall be separated by sheet-metal baffles extending below the sprinkler deflectors. When an approved automatic sprinkler system with open heads is permitted by the inspection department having jurisdiction, the baffles between heads may be omitted.

(176) *Lights*.—All lights in film vaults shall be at the ceiling and of

the fixed type, with vapor-proof globes and conduit wiring. All switches shall be outside the vault and should be arranged with a small pilot light to indicate on outside of vault whether vault lights are on or off.

(177) *Heat*.—Heating, when required to prevent sprinkler pipes freezing, shall be by hot water or low pressure steam with automatic control limiting steam pressure to 10 pounds and the vault temperature to not in excess 70 degrees F. Radiators shall be placed at the ceiling, over aisle space with pipes and radiators protected with wire guards so arranged that no film can be placed within 12 inches of such pipes or radiators.

(178) All film in vaults shall be in containers, either in single-roll containers which shall be kept on edge on racks only, except that negatives need not be stored on edge, or in I. C. C. shipping containers which may be kept on the floor. Materials other than film and film cement shall not be stored in the vault.

Section 18.—Handling of Film

(181) *Film Shall Be in Containers*.—All film shall be kept in closed containers except during the actual time it is being worked upon or examined. This is very essential from the standpoint of fire hazard and safety to life. I. C. C. shipping containers and individual containers for each roll of film with proper corrugations on each side are recommended.

(182) Film shall not be placed or kept under benches, tables, or other surfaces which would shield it from the discharge of sprinklers.

(183) *Scrap Film*.—Scrap film shall be kept separate from waste paper and other rubbish, and shall be kept under water at all times. It shall be collected from work rooms at least once daily, and removed to a room used for no other purpose, where it shall be kept under water in steel drums with tight covers. These drums shall be disposed of at frequent intervals. Discarded film in full or part rolls shall be kept in vaults. Scrap film shall not be baled or burned.

NOTE.—Motion picture film in the form of clippings and short lengths is in a very hazardous form. Safe precautions in the handling of such scraps are most essential. Baling and burning of film are processes offering a distinct fire hazard. Sending film to a central reclaiming plant in lieu of burning is recommended.

(184) *Transportation*.—(a) Motion picture film should never be transported in any vehicle or other public conveyance used for the

transportation of passengers, unless enclosed in I. C. C. shipping containers.

(b) Motion picture film should never be allowed in any underground subway train or station unless under the jurisdiction of the Interstate Commerce Commission and conforming to the regulations thereof.

Section 19.—Motion Picture Projection and Special Processes

(191) *Enclosures for Motion Picture Projectors.*—(a) Motion picture projectors using nitrocellulose film shall be operated or set up for operation only within an approved enclosure, not less than 48 square feet in size and 7 feet high. If more than one machine is to be operated an additional 24 square feet shall be provided for each additional machine.

For new construction, a size not less than 8 feet wide, 10 feet deep, and 8 feet high is recommended for one projection machine, and not less than 14 feet wide, 10 feet deep, and 8 feet high for two machines.

(b) The walls and ceiling of the enclosure shall be built of brick, tile, or plaster blocks, plastered on both sides, or of concrete, or a rigid metal frame, properly braced, and sheathed and roofed with sheet iron of not less than No. 20 U. S. gauge metal, or with $\frac{1}{4}$ -inch hard asbestos board, securely riveted or bolted to the frame, or 2 inches of solid metal lath and cement or gypsum plaster. All joints shall be sufficiently tight to prevent the discharge of smoke. Non-combustible acoustical material may be used on ceiling and walls, on top of the plaster.

For new construction, it is recommended that the walls of the enclosure be constructed in accordance with the requirements of subsection 112, paragraphs (1), (2), or (3), for partitions, with floor and ceiling of equivalent fire resistance. Modern heavy equipment may require special attention to floor strength and support. In some cases it may be necessary to support the projection room independently of the structure.

(c) The entrance door into the enclosure shall be at least 2 feet by 5 feet, of construction equivalent to the sheathing permitted above for rigid frame construction, and shall be self-closing, swinging out, and shall be kept closed at all times when not used for egress or ingress.

For new construction it is recommended that at least two doors be provided, each not less than 30 inches wide and 6 feet high. Doors

should be approved fire doors of a type suitable for use in corridor and room partitions (Class C openings as defined in the *Regulations on Protection of Openings in Walls and Partitions*). Exits should be in accordance with requirements of authorities having jurisdiction, particularly as to size and location. At least one should be of the conventional stairway type, having a suitable landing at the top or should open directly onto a corridor.

(d) Two openings for each motion picture projector shall be provided; one for the projectionist's view (observation port) shall be not larger than 200 square inches, and the other through which the picture is projected (projection port) shall be not larger than 120 square inches. Where separate stereopticon, spot, or flood light machines are installed in the same enclosure with picture machines, not more than one opening for each such machine shall be provided for both the operator's view and for the projection of the light, but two or more machines may be operated through the same opening; such openings shall be as small as practicable and shall be capable of being protected by approved automatic shutters.

(e) Each opening shall be provided with an approved gravity shutter set into guides not less than one inch at sides and bottom, and overlapping the top of the opening by not less than one inch when closed. Shutters shall be of not less than 10-gauge iron or its equivalent, or of $\frac{1}{4}$ -inch hard asbestos board. Guides shall be of not less than 10-gauge iron or its equivalent. Shutters shall be suspended, arranged, and interconnected so that all openings will close upon the operating of some suitable fusible or mechanical releasing device, designed to operate automatically in case of fire or other contingency requiring the immediate and complete isolation of the contents of the enclosure from other portions of the building. Each shutter shall have a fusible link above it, and there shall also be one located over each upper projector magazine which, upon operating, will close all the shutters. There shall also be provided suitable means for manually closing all shutters simultaneously from any projector head and from a point within the projection room near each exit door. Shutters on openings not in use shall be kept closed.

(f) All shelves, furniture, and fixtures within the enclosure shall be constructed of incombustible material. Tables shall conform to paragraph 117. No combustible material of any sort whatever shall be permitted or allowed to be within such enclosure, except the films used in the operation of the machine, and film cement. See Section 214.

(g) Ventilation shall be provided by one or more mechanical exhaust systems which shall draw air from each arc lamp housing and from one or more points near the ceiling. Systems shall exhaust to outdoors either directly or through a non-combustible flue used for no other purpose. Exhaust capacity shall be not less than 15 nor more than 50 cubic feet per minute for each arc lamp plus 200 cubic feet per minute for the room itself. Systems shall be controlled from within the enclosure and have pilot lights to indicate operation. The exhaust system serving the projection room may be extended to cover rooms associated therewith such as rewind rooms. No dampers shall be installed in such exhaust systems. Ventilation of these rooms shall not be connected in any way with ventilating or air conditioning systems serving other portions of the building.

(h) Exhaust ducts shall be of non-combustible material, and shall either be kept 1 inch from combustible material or covered with $\frac{1}{2}$ -inch of non-combustible heat insulating material.

(i) Fresh air intakes other than those direct to the open air shall be protected by approved fire shutters arranged to operate automatically with the port shutters.

(j) Provision shall be made so that the auditorium lights can be turned on from inside the projection room and from at least one other convenient point in the building.

NOTE.—Automatic sprinklers in projection rooms have been very successful controlling fires and reducing losses, and their installation is recommended wherever practicable.

(193) *Processing of Film.*—The processing of film, as cleaning, polishing, buffing, and other special treatments shall not be done in rooms where other operations are performed, except that in motion picture theaters, cleaning of film may be done in the rewind room. (See paragraph 212.) Special processes for treating film shall be provided with such proper safeguards as are necessary for protection against the hazards involved. The inspection department having jurisdiction shall be consulted in regard to the protection needed.

(194) *Soldering Cases.*—Soldering cases of film when done in a building shall be conducted in a room used for no other purpose. Walls of the room shall be constructed of 6-inch hollow tile plastered each side to a thickness of $\frac{1}{2}$ inch or its equivalent. Area of room shall not exceed 60 square feet. Opening to room shall not be from another film handling room; it shall be protected by an approved self-

closing Class *B* fire door. Automatic vent shall be provided with a ratio of 70 square inches for each 500 pounds of film. Rooms shall be equipped with automatic sprinklers with a ratio of one sprinkler for each 15 square feet with proper sheet-metal baffles. Quantity of film in room shall not exceed one case.

NOTE.—The use of shipping cases with metal linings of the telescope type which do not need to be soldered is recommended.

(195) *Silver Reclaiming*.—The process of reclaiming silver from film shall not be carried on in a building with other processes unless cut off therefrom by standard fire walls. Such sections shall be completely equipped with automatic sprinklers.

(196) *Film Cement*.—Compounds of collodion, amyl acetate, or similarly flammable cements shall not be kept in the rooms where they are used, in quantities greater than 1 quart; and such material in excess of this quantity shall be kept in a vault. The use of these materials in motion picture theaters and other special occupancies is covered in sub-section 214.

(197) *Smoking*.—Smoking, except in rooms especially provided for the purpose, should be prohibited in any establishment handling or storing film, and conspicuous “No Smoking” signs should be posted in prominent places. Matches should not be carried by any employee.

PART II. SPECIAL PROVISIONS FOR SPECIAL OCCUPANCIES

NOTE.—It is the intent of the regulations to permit the use of 2000-foot rolls of 35-mm film in theaters and exchanges only, when handled and stored as prescribed. The limitations on quantities permitted are based on weight.

Section 21.—Motion Picture Theaters and Other Occupancies in Which the Principal Use of Film Is in Motion Picture Projection

(211) *Enclosure for Projectors*.—Motion picture projectors shall be installed in an enclosure in accordance with sub-section 191.

(212) *Rewinding*.—(a) Rewinding of films shall be performed either in a special rewind room at an approved location, or in the projection room. If done in the projection room, approved enclosed-type rewind machines should be used. An approved can for scrap film having a self-closing hinged cover shall be provided.

(b) Rewind rooms shall be at least 80 square feet in area, with walls and doors in accordance with the requirements of sub-section 112 and with ceiling of equivalent fire resistance, and shall have a

vent to the outside of the building of not less than 27 square inches. [See paragraph 191(g).] Exhaust ducts shall comply with paragraph 191 (h). Shelves, furniture, and fixtures shall comply with paragraph 191(f).

(213) *Care and Use of Film.*—Motion picture film used in connection with the projection of motion pictures (as in theaters, motion picture theaters, screening or projection rooms, sound recording studios, and motion picture titling studios) shall be limited and kept as follows:

(a) The quantity of film in any projection room or rewinding room not equipped with an approved system of automatic sprinklers shall be limited to that given below; if equipped with an approved system of automatic sprinklers, double the quantity specified may be permitted.

(1) In a projection room, constructed of brick, hollow tile, concrete, or other approved masonry, not exceeding 125 pounds (25,000 feet of 35-mm film);

(2) In a rewinding room constructed of brick, hollow tile, concrete, or other approved masonry, separated from projection room with openings thereto protected with approved fire doors, not exceeding 125 pounds (25,000 feet of 35-mm film);

(3) In a projection booth constructed of metal frame covered with asbestos board or sheet iron not exceeding 75 pounds (15,000 feet of 35-mm film);

(4) In a special room constructed and vented as required for rewinding rooms (see sub-section 212), when approved by the inspection department having jurisdiction, not exceeding 125 pounds may be kept in lieu of the amount permitted in either the projection room or the rewind room. The total quantity in the three rooms shall not exceed 250 pounds (50,000 feet of 35-mm film).

(b) The above quantities of film shall be kept as follows:

(1) Up to 40 pounds (8000 feet of 35-mm film) of film may be kept in Interstate Commerce Commission shipping containers, or approved cabinet in each room;

(2) If the amount of film on hand exceeds 40 pounds, an approved cabinet shall be provided, in which the amount of film in excess of 40 pounds shall be kept.

(214) No collodion, amyl acetate, or other similar flammable cement or liquid in quantities greater than 1 pint shall be kept in the projection booth or room or rewind room.

(215) Splices in film shall be made on mechanical cutting and splicing machines. See paragraph 212(a) on handling of scrap film.

(216) *Location*.—The number and location of motion picture projection rooms or booths in any non-sprinklered building shall be subject to the approval of the inspection department having jurisdiction.

(217) *Operation*.—Motion picture projectors shall be operated by and be in charge of qualified projectionists, who shall not be minors.

(218) *Procedure in Case of Fire*.—In the event of film fire in a projector or elsewhere in a projection or rewind room, the projectionist should immediately shut down the projection machine and arc lamps, operate the shutter release at the nearest point to him, turn on the auditorium lights, leave the projection room, and notify the manager of the theater or building.

Section 22.—Motion Picture Film Exchanges

(See Part I, *General Provisions*, which also apply.)

(221) *Sprinkler Protection*.—Buildings not of fireproof construction, housing an exchange, shall be completely equipped with automatic sprinklers. Buildings of fireproof construction shall be equipped from and including the lowest floor on which film is handled to the top of the building with an approved automatic sprinkler system. It is recommended that the sprinkler system extend throughout the building.

(222) Exchanges shall be provided with one or more independent rooms to be used exclusively for receiving and delivering film, and also one or more separate rooms for the purpose of inspecting, examining, and repairing film, and one or more rooms for the storage of posters or other combustible materials.

(223) *Shipping Room*.—One or more vaults or cabinets shall be provided in connection with the receiving and shipping room of exchanges into which all film shall be placed and kept except during such time as is necessary for checking, sorting, and shipping. All film outside the vaults and cabinets, except while actually being handled, shall be kept in I. C. C. containers.

NOTE.—With the enforcement of the above general principles of operation, the total quantity of film, including that which is in I. C. C. containers, in the receiving and shipping room of any exchange should ordinarily not exceed 100 to 150 standard rolls or 50 to 75 double rolls, with a maximum limit, which should never be exceeded, of 300 standard rolls or 150 double rolls or 1500 pounds.

(224) *Quantity of Film.*—In inspection, projection, rewinding, and other rooms (not including shipping room) there shall not be in excess of 16 standard rolls or 8 double rolls for each person handling film in such rooms, of which not in excess of 2 standard rolls or one double roll for each person shall be exposed outside of closed containers. All film in excess of this quantity shall be kept in cabinets or vaults.

Section 23.—Motion Picture Film Laboratories

(See Part I, *General Provisions*, which also apply.)

(231) All buildings used for, or housing a motion picture film laboratory shall be equipped throughout with automatic sprinklers.

(232) *Quantity of Film.*—In all the various work rooms in which film is handled (not including shipping rooms) the quantity of film not in containers shall not exceed two standard rolls per person handling film; this should not be construed, however, as restricting the quantity of film which may be in process on printing, developing, or drying machines to two standard rolls. There shall not be more than 10 standard rolls of film not in approved cabinets for each person working in such rooms; provided, however, that in developing rooms there shall not be more than 20 standard rolls of film not in approved cabinets for each developing unit. All film in excess of the above quantities shall be kept in cabinets or vaults.

(233) *Printing.*—On all future installations, unless printing machines are so spaced that the distance from the film on any machine to that on any other machine is at least 6 feet, they shall be separated from each other by incombustible partitions of $\frac{3}{8}$ -inch hard asbestos board or its equivalent in heat insulation and durability, and extending from the floor to at least 3 feet above the top of the film on the machines. If partitions carried to this height would extend higher than 2 feet below sprinkler deflectors, they shall be built up to the ceiling. If partitions are extended to the ceiling one sprinkler head shall be located in each of the sections thus formed. In any event, sprinklers shall be so arranged that not more than two machines are dependent upon the protection afforded by any one head.

(234) *Drying.*—Drying machines of the cabinet type shall be of metal and wired glass. Heating units shall be located outside the cabinet, and shall be provided with thermostatic control so that the temperature in the cabinet shall not exceed 120°F.

(235) *Waxing*.—Waxing film shall be done in a separate room. Waxing processes which require the waxed film to be left exposed to dry shall be in a room used for no other purpose and not over 5 such machines shall be located in one room. Not over 25 standard rolls or 25,000 feet of film shall be exposed at one time.

(236) *Projectors*.—Not more than 5 motion picture projectors shall be located in one room, unless the projectors are of a type using incandescent electric lights of not over 25-watt size when not more than 10 projectors shall be located in one room.

(237) *Shipping Room*.—(a) The shipping room shall be separated from the rest of the building by partitions constructed in accordance with the provisions of sub-section 112. No other process than packing of film shall be conducted in the shipping room.

(b) Not over 500 standard rolls of film shall be in a shipping room at one time, of which the quantity not in shipping cases shall not exceed 250 standard rolls. See sub-section 181.

Section 24.—*Motion Picture Studios*

(See Part I, *General Provisions*, which also apply.)

(241) Buildings housing motion picture studios shall be completely equipped with automatic sprinklers, except that upon specific approval of the inspection department having jurisdiction, sprinklers may be omitted in rooms of a construction having a fire retardant classification of not less than one hour and used only for housing valuable electrical equipment and in which no film or other hazardous materials are handled or stored.

NOTE.—For sound recording studios and motion picture titling studios see Section 21.

(242) (a) On the studio stage there shall be no film except in the magazines of cameras or sound recording apparatus of which there shall not exceed two magazine units for each camera or recording apparatus.

In other sections of a motion picture studio the quantity of film not in containers shall not exceed one standard roll per person handling such film.

(b) Extra, loaded magazines may be kept in special magazine room. The number of loaded magazines in one such room shall not exceed 50. They shall be kept on open metal racks. Such rooms shall be used for the loading and storing of magazines only.

(c) In all sections of a motion picture studio other than the stage and magazine rooms, the quantity of film in a room shall not exceed 10 standard rolls per person handling film, in addition to what may be kept in cabinets.

(d) All film in excess of the quantities permitted above shall be kept in cabinets or vaults.

(243) Vaults and/or cabinets shall be located in a section separated from the studio stage by partitions. (See sub-section 112.)

(214) Sections of a studio in which the work is of the same general character as that in a laboratory shall be governed by the provisions of Section 23, *Laboratories*.

(245) (a) Carpenter shops, property storage rooms, costume rooms, and dressing rooms shall be separated from the studio stage by fire partitions constructed of 8 inches of brick, or of some other construction of incombustible materials and suitable stability, having a fire retardant classification of not less than 2 hours as determined by the Standard Fire Test.

(b) Only such openings as are necessary shall be provided in such fire partitions and shall be protected by approved fire doors of a type suitable for use in Class B situations as defined in the *Regulations for the Protection of Openings in Walls and Partitions against Fire*; openings of larger than standard size may be provided when necessary if protected by approved oversize fire doors.

(246) Materials constituting a permanent finish or interior surfacing on ceilings, permanent partitions, and walls, and used to reduce the reflection or transmission of sound, shall, if not incombustible, be or treated so as to be of an approved slow burning composition or character.

(247) All fabrics of monk's cloth, canvas, muslin, burlap, silk, satin, velvet, velour, or similar material suspended from ceilings or gridirons or hanging against walls or partitions, and all backdrops, cycloramas, and other theatrical appurtenances constructed in whole or in part of muslin, canvas, burlap, and all artificial or natural trees, shrubbery, grass mats, straw, hay, and similar combustible material shall be painted, sprayed, or saturated with fire retarding or flame proofing material or otherwise rendered safe against fire; provided, however, that furnishings of silk, satin, velvet, and velour which are used in sets and included in the photographing of scenes need not be so treated.

NEW MOTION PICTURE APPARATUS

During the Conventions of the Society, symposiums on new motion picture apparatus are held, in which various manufacturers of equipment describe and demonstrate their new products and developments. Some of this equipment is described in the following pages; the remainder will be published in subsequent issues of the Journal.

A FLEXIBLE TIME-LAPSE OUTFIT*

A. B. FULLER AND W. W. EATON**

Motion pictures which have been produced by exposing single frames at regularly spaced intervals and then projecting the film in the ordinary way constitute a valuable method of studying growths or movements which take place at a relatively slow rate. By way of contrast to our familiar slow-motion pictures, such movies may be called "fast-motion" pictures because they apparently speed up the action and cause it to appear to take place faster than it actually did. These "time-lapse" pictures find their most frequent application in the study of growing plants or cells and similar subjects; for the growth or movement which required weeks or months may be condensed to a few moments on the screen and is available for repetition and study.

The essentials for time-lapse photography are a motion picture camera that can be actuated one frame at a time and an automatic method of actuating such a camera at intervals which are adjustable to suit the rate of growth or motion being studied. As far as the camera is concerned, the Cine-Kodak Special is well suited for this type of work, and the apparatus to be described has been built to be used in conjunction with it. An automatic method of actuating the camera at desired intervals is a necessity, since in most cases it would be entirely impracticable for an operator to do this. The purpose of this paper is to describe briefly an apparatus which has been designed by the Eastman Kodak Company to meet such a need. The principal requirements for such an outfit are flexibility and convenience.

In some cases it may be desirable to make pictures a few seconds or a fraction of a second apart, because the movement being studied is relatively fast. In other circumstances, the interval between successive pictures may have to be minutes or even many hours in order to produce the desired amount of action on the screen in a reasonable length of time when the film is finally projected as

* Presented at the 1939 Meeting at New York, N. Y.; received September 30, 1939.

** Eastman Kodak Co., Rochester, N. Y.

a motion picture. In addition, such an outfit should be convenient to use and should be easily portable. Finally, since so many subjects will require artificial illumination, it is important to have an automatic method of turning the lights on for the exposure and turning them off afterward, no matter what the interval between pictures may be. The equipment which has been constructed to meet the above requirements is known as the Electric Time Lapse Outfit. It consists



FIG. 1. The Electric Release Control for the Cine-Kodak Special, consisting of the Electric Release, which is mounted on the camera, and the Electric Release Control box, which supplies the necessary impulses to control the camera action.

of two parts, the Electric Release Control and the Interval Timer, which will be described separately.

The Electric Release Control.—The Electric Release Control is shown in Fig. 1. It consists of the Electric Release, which attaches to the Cine-Kodak Special, and the Electric Release Control box. The Electric Release contains an electromagnet, to which electrical energy is supplied by the Electric Release Control box. It is mounted on the camera, as shown in the illustration, in such a way that when energized momentarily the electromagnet pulls an armature away

from a butterfly cam placed on the one-frame shaft of the camera and allows the shaft to rotate either a half or a full turn under the camera's own power, according to the position of a control lever. A half-rotation of the shaft changes the camera shutter from closed to open, or the reverse. This action, which corresponds to that of an ordinary "still" camera shutter when set on *Time*, permits time exposures to be made. In another position of the control lever the shaft is allowed to make a complete revolution for each impulse supplied from the Electric Release Control box. This results in instantaneous exposures.

The Electric Release Control box houses the electrical equipment needed for the control of the electromagnet in the Electric Release. By means of proper settings it is possible to supply momentary impulses to the Electric Release in a variety of ways. Either instantaneous, time, or bulb exposures can be made manually by the operator, or instantaneous exposures can be made automatically at intervals of from $\frac{1}{4}$ to 6 seconds, through the use of a condenser-resistance timing circuit. Also, it is possible for either the operator or some external timing device to initiate single, automatically timed exposures which may be set throughout a range of $\frac{1}{4}$ to 6 seconds. And, finally, a remote control of the ordinary camera action is provided by allowing the electromagnet to be energized continuously so that the camera is free to run in the normal way.

Although power is normally supplied from four self-contained flashlight cells, provision is made on the panel for connecting an external 6-volt battery for long, unbroken runs. Also, a hand-control switch is provided which can be used in place of the control button on the panel, thus allowing the operator considerable freedom of movement while still retaining control of the camera.

The Electric Release Control thus presents in itself complete manual and limited automatic control of the Cine-Kodak Special in applications where individual film frames are exposed at intervals or where remote control of the ordinary camera action is desired. It is especially intended for animation work, growth studies, and similar projects. Although it will automatically take instantaneous pictures spaced no more than six seconds apart, these intervals are quite satisfactory for many types of growth or other work. When used in conjunction with a timer and lamp control, such as will be described below, its range and usefulness are extended so that it will cover almost any conceivable application.

The Interval Timer.—The Interval Timer is an instrument which has been designed primarily for use in conjunction with the Electric Release Control and the Cine-Kodak Special. Its functions are to actuate the Electric Release Control at intervals, and thus cause either instantaneous or time exposures to be made and, in addition, to provide means for turning on and off the lights required in many cases. Like the Electric Release Control, the Interval Timer has self-contained flashlight cells, but facilities are provided for the use of an external battery when needed. As in the Electric Release Control, the basic timing circuit is achieved by means of a condenser being charged through a resistance. In the Interval Timer the timing circuit provides regularly spaced impulses according to its setting, which come either $\frac{1}{4}$ second or $\frac{1}{4}$ minute apart. Through the use of a fixed multiplier which introduces a factor of 60, a basic interval of $\frac{1}{4}$ hour is also possible. The fundamental idea of the instrument is to multiply one of these basic times by a predetermined factor in order to achieve a different longer interval. The impulses are used in a variable multi-

plier to index a ratchet wheel forward, one tooth at a time, by means of an actuating relay. After a certain number of impulses, a contact on the wheel strikes an adjustable contact which causes the wheel to reset automatically to its zero position. This action of resetting determines the completion of the interval or cycle. It turns on the lamps and subsequently starts the exposure *via* the Electric Release Control, or in case the lamp control is not being used, initiates the exposure directly. The number of impulses necessary for resetting is deter-



FIG. 2. The complete Electric Time Lapse Outfit, shown with the Cine-Kodak Special. The Interval Timer is in the foreground, the Electric Release Control box is at the left, and the Electric Release is mounted on the camera.

mined by means of a dial knob on the panel, and may be set from 1 to 96. This setting, together with the selection by another knob of the basic time which is to be used, determines the interval for which the machine is set. At the end of every such interval the machine will reset automatically, initiate an exposure through the Electric Release Control, and proceed to time the next interval. The scales are so arranged that the instrument may be set to initiate exposures at intervals from $\frac{1}{4}$ second to 24 seconds in $\frac{1}{4}$ -second steps, from $\frac{1}{4}$ minute to 24 minutes in $\frac{1}{4}$ -minute steps, and from $\frac{1}{4}$ hour to 24 hours in $\frac{1}{4}$ -hour steps.

For almost all time-lapse work which extends longer than a few hours, it is desirable to have the subject illuminated by artificial light so that the exposure

and general lighting may be kept uniform. For pictures spaced farther apart than about half a minute or so, it is equally undesirable to have the lamps burning continuously, particularly if they are of the Photoflood type and considerable light is required. For this reason it was decided to incorporate into the Interval Timer an automatic lamp control so that the lamps would be turned on before the exposure is made, and turned off afterward, regardless of the interval between pictures. This is accomplished by providing a small synchronous line-voltage motor which controls the lamp circuit. When the end of the cycle is reached and the wheel resets, the lamps are turned on, and shortly thereafter the Electric Release Control is activated, thus causing the exposure to take place. Eight seconds after the lights go on they are automatically cut off, regardless of the duration of exposure. This is to cover the longest time exposure possible—namely, 6 seconds. In case pictures are being made at intervals of a few seconds, the lamp control circuit is not used and the lights are simply plugged directly into the line. Under such conditions, or where the lamp control is not desired, the motor is not used, and therefore no power line to the Interval Timer is necessary.

The Complete Time-Lapse Outfit.—Although the Electric Release Control may be used alone with the Cine-Kodak Special in many instances, it is the addition of the Interval Timer to form the complete Electric Time-Lapse Outfit which provides the most convenient way of meeting almost any growth study or similar problem. The complete outfit is illustrated, with the Special, in Fig. 2. Operation is simple and there are relatively few steps involved in setting up the equipment to make a time-lapse film. The Electric Release, together with the cam which governs the action of the one-frame shaft, must be mounted on the camera and proper connections made to the Electric Release Control box, and from it to the Interval Timer. In case lamps are to be used, they are plugged into an outlet on the Interval Timer panel, and the power line which furnishes the lamp current is connected to a corresponding receptacle. Assuming the necessary camera and lighting adjustments to be made, the actual exposure time desired is set by means of knobs on the Electric Release Control box panel. This may be either instantaneous, varying with camera settings from $\frac{1}{100}$ second to $\frac{1}{20}$ second, or a time exposure which may be set throughout a range of $\frac{1}{4}$ second to 6 seconds. The interval desired between the beginning of successive exposures is set by means of the two control knobs on the Interval Timer panel, as explained previously. It is important to note that the exposure settings and the interval time settings are entirely independent. All that remains is to turn a control switch, and the complete outfit will function without any attention whatsoever, as long as the spring motor in the camera is not run down. During the progress of the run any necessary changes in the adjustments to compensate for changes in growth rate or lighting may be easily made without interrupting the action of the outfit. Inasmuch as both units have self-contained batteries, the outfit is easily portable. Unless power for the lamps is wanted, a power line is not necessary.

The complete outfit as described thus provides all the equipment (not including camera) necessary for making time-lapse films. Although a great many uses of such an outfit lie in the field of growth study work, it has, of course, applications in many other fields as well. For example, in recording the progress of a con-

struction project, in recording the readings of meters or controls at desired intervals, in traffic-control study, and in fact, in any application where the motion or growth occurs at such a rate that it is convenient to condense it for the purposes of study, such equipment should be extremely useful.

DISCUSSION

MR. FLORY: What load will the interval-timer accommodate on the lamp circuit?

MR. EATON: It is rated at 10 amperes, 115 volts.

MR. FLORY: Can you use an external source of power, such as a 6-volt battery?

MR. EATON: Either of these boxes can be used either with its own self-contained batteries, or with an external battery. The same 6-volt battery will function for both of the units.

MR. BRADY: Could the outfit be used for submarine work; say, in a diving bell?

MR. EATON: Certainly. The only limitation is the fact that the camera spring motor will run down after a certain length of time, depending upon the interval between the pictures. The camera has a long run—about 40 feet of 16-mm film—but if pictures are taken every second or thereabouts, the film will be used up very rapidly. On the other hand, if the interval is longer—say, one picture an hour—the camera will operate for a long time without attention.

MR. HOLSLAG: Does the apparatus permit the use of a motor drive?

MR. EATON: There is a motor drive, of course, as an accessory for the Cine-Kodak Special, but it would have to be adapted to be used with this time-lapse outfit. If you had a special problem that you wanted to work out, it could be done, using the outfit as a basis.

FILM SPLICER FOR DEVELOPING MACHINES*

J. G. CAPSTAFF AND J. S. BEGGS**

The splicer to be described was developed for use on high-speed, sprocketless, 35-mm developing machines. Above all else, such a splice must be dependable; that is, it must not catch on guards or blow-offs, and must not pull apart in spite of passing around hundreds of small pulleys. Metallic fastening devices localize the stresses which are apt to start tears. By using a special adhesive tape to make the splice, the stress is distributed over the full width of the film. To prevent the tape from being soaked loose in the developing solutions, its "linen" base is waterproofed, and a hole is punched through the center of the film at each edge of the tape. The tape thus sticks to itself through these holes, preventing the edge of the tape from lifting when the emulsion swells. The ends

* Presented at the 1939 Fall Meeting at New York, N. Y.; received October 15, 1939.

** Eastman Kodak Co., Rochester, N. Y.

of the film to be spliced are placed end-to-end with a space of $\frac{1}{16}$ inch between, and the tape is passed tightly around both sides, overlapped in the center of the film, and pressed down firmly. The splice will withstand a pull of 50 pounds, is

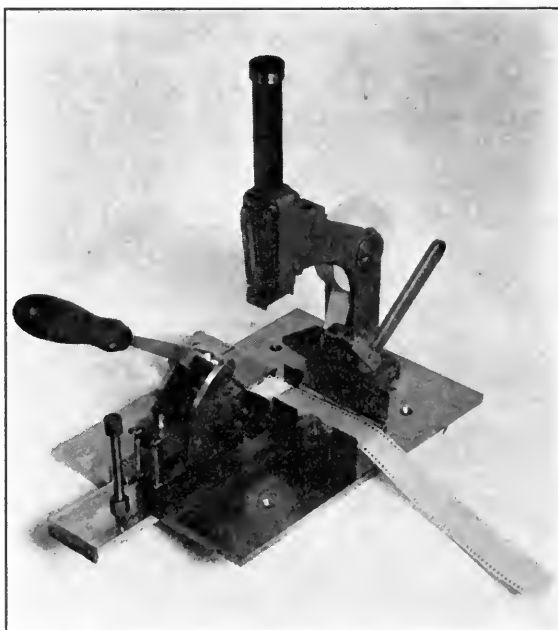

FIG. 1. The first model.



FIG. 2. The final splicer.

smooth, and thus will not catch in the machine. Being quite thin, it will pass through blow-offs, and as many as forty splices have been taken up in a 2000-ft. roll without damaging the film or making the roll badly out of round.

Two splicers have been designed to make this splice. The first one (Fig. 1) built prepares both films simultaneously in a punch and die, dispenses the tape and creases it sharply around the sides of the film, and has a device for squeezing the splice between two rubber pads with great force. This gives very intimate contact between the adhesive and the film and forces the tape to stick to itself through the holes in the center of the film and the perforation areas. The edges of the film are also cut away about $\frac{1}{64}$ inch where the tape passes around the film so that the splice does not project even the thickness of the tape. The splicer is fitted with a small green safelight which projects a small spot of light on the splicing position and comes on automatically when the end of the film passes between two rollers. The same action causes a solenoid-operated brake to hold the film so that the end is in approximate position for splicing. An experienced operator requires 12 seconds to make a splice in the dark using this splicer.

Although this first splicer was satisfactory from a performance standpoint, its cost was too great. To meet this objection, one of the authors designed the second model (Fig. 2). This model may be built at about one-tenth of the cost of the former. It works as follows:

The end of the roll of film is placed in the punch and die, and three $\frac{5}{16}$ -inch holes spaced $\frac{1}{2}$ inch apart are punched on its centerline and the end trimmed square. The two holes away from the end are then placed over two of the pegs at the front of the splicer. The trailing end of the leader is treated in a similar manner, the same perforators making the holes, but a knife on the other edge of the die is used to trim the end. The leader is then placed on the remaining pair of pegs which line it up with the film so as to leave a $\frac{1}{16}$ -inch space between the ends. A piece of tape about $3\frac{1}{4}$ inches long which had previously been placed symmetrically with respect to this space between the films, and sticky side up, is wrapped tightly around the film. The splice is then removed and the tape pressed firmly into contact with the film and with itself through the holes in the film. The space between the ends of the film helps to make the splice flexible for passing around pulleys.

DISCUSSION

MR. CRABTREE: What are the advantages of this type as compared with other types of splices, as, for example, the Mercer patch, or staple, or actual cementing of the films?

MR. BEGGS: The splice is absolutely safe in a developing machine. It will not pull apart, and in leader it will go through hundreds of times without damage.

MR. PALMER: Have you tried to make a splice and maintain the sprocket hole so that the film will run over a sprocket?

MR. BEGGS: We do not recommend the splice for sprocket machines, although we are actually using it on a low-speed sprocket machine. It seems to behave all right. All you have to do is to splice with the sprocket holes in register and not perforate the tape. It will climb over the sprocket all right but slips a tooth once in a while.

CURRENT LITERATURE OF INTEREST TO THE MOTION PICTURE ENGINEER

The editors present for convenient reference a list of articles dealing with subjects cognate to motion picture engineering published in a number of selected journals. Photostatic copies may be obtained from the Library of Congress, Washington, D. C., or from the New York Public Library, New York, N. Y. Micro copies of articles in magazines that are available may be obtained from the Bibliofilm Service, Department of Agriculture, Washington, D. C.

American Cinematographer

21 (January, 1940), No. 1

- | | |
|---|-------------------------------|
| Camera Technique Dominates Filming Results (pp. 11, 42-43) | C. W. CARDARETTE |
| Amateur Progress in 1939 Exceeded Professional (pp. 16-17), Pt. I | W. STULL |
| Studying Photoelectric Exposure Metering (pp. 18-21, 44-45), Pt. II | D. NORWOOD |
| DuPont's Superior II Combines Speed, Fine Grain, Wide Latitude (p. 22) | H. W. MOYSE |
| Composition Is Simple—Perhaps—but Very Important (pp. 27-28, 39) | J. A. SHERLOCK |
| Obtaining Increased Illumination from Fine Grain Film Recording (p. 36) | O. L. DUPY AND J. K. HILLIARD |
| Simple Changes Improve Camera Equipment (pp. 38, 46) | E. KEARNS |

British Journal of Photography

86 (November 24, 1939), No. 4151

- | | |
|---|--|
| Progress in Color (pp. 695-696) | |
| The Projector in Detail, Sound-on-Film Projectors (pp. 696-698) | |
| Progress in Color (pp. 708-709) | |
| 86 (December 8, 1939), No. 4153 | |
| Progress in Color (pp. 723-724) | |

Electronics

12 (December, 1939), No. 12

- | | |
|-----------------------------------|-------------|
| Disc-Cutting Problems (pp. 17-19) | C. J. LEBEL |
|-----------------------------------|-------------|

General Electric Review

42 (December), No. 12

- | | |
|--|--|
| Spectral Distribution of Radiation from Lamps of Various Types (pp. 540-543) | B. T. BARNES,
W. E. FORSYTHE,
AND W. J. KARASH |
|--|--|

International Photographer

11 (December, 1939), No. 11

Multiplane Camera for "Pinocchio" (p. 4)

Television Camera Operation (p. 17)

N. C. McEDWARD

Kinotechnik

21 (November, 1939), No. 11

Normung der Tonspur beim 16-Mm Schmalfilm (Standardization of Sound-Track for 16-Mm Film) (pp. 247-248)

A. HEINE

Die Verwertung von Altfilm-Material (Use of Old Film Stock) (pp. 250-253)

E. RADLOFF

Die Reichsverordnung Über den Sicherheitsfilm vom 30. Oktober 1939 (Safety Film Ordinance of October 30, 1939) (pp. 253-254)

J. GRASSMANN

International Projectionist

14 (November, 1939), No. 10

The Effect of P. E. Cell Cable on Sound-Film Reproduction Quality (pp. 7-8, 11)

A. R. HAMILTON

Assaying Projector Carbon Performance (pp. 12-15)

F. S. HAWKINS

Safekeeping the Picture Industry (pp. 15-16)

K. W. KEENE

Technicolor Adventures in Cinemaland (pp. 17-19, 23-25)

Motion Picture Herald (Better Theaters Section)

137 (December 9, 1939), No. 10

Economical Mirror Maintenance for Effective "Suprex" Carbon Arcs (pp. 35-36, 38, 43)

H. D. BEHR

Photographische Industrie

37 (November 15, 1939), No. 46

Untersuchung über ein Tontrennungsverfahren (Investigation on a Sound Separation Method) (pp. 1142-1143), Pt. I

H. BACKSTROM

37 (November 22, 1939), No. 47

Untersuchung über ein Tontrennungsverfahren (Investigation on a Sound Separation Method) (pp. 1156-1158), Pt. II

H. HAFSTROM,
H. BACKSTROM,
AND H. HAFTSROM

1940 SPRING CONVENTION

SOCIETY OF MOTION PICTURE ENGINEERS

CHALFONTE-HADDON HALL, ATLANTIC CITY, NEW JERSEY
APRIL 22-25, INCLUSIVE

Officers and Committees in Charge

E. A. WILLIFORD, *President*
S. K. WOLF, *Past-President*
W. C. KUNZMANN, *Convention Vice-President*
J. I. CRABTREE, *Editorial Vice-President*
S. HARRIS, *Chairman, Papers Committee*
J. HABER, *Chairman, Publicity Committee*
H. GRIFFIN, *Chairman, Convention Projection*
E. R. GEIB, *Chairman, Membership Committee*
H. BLUMBERG, *Chairman, Local Arrangements*

Reception and Local Arrangements

HARRY BLUMBERG, *Chairman*

M. C. BATSEL	E. O. WILSCHKE	E. W. KELLOGG
A. B. FREEMAN	W. J. CHARLES	H. WALTERS
C. A. SEUBERT	M. LEWIS	F. B. EVANS
C. W. TREEN	W. CONNER	L. RATENER

Registration and Information

W. C. KUNZMANN, *Chairman*

E. R. GEIB	J. FRANK, JR.	F. HOHMEISTER
------------	---------------	---------------

Hotel and Transportation

E. O. WILSCHKE, *Chairman*

S. ABRAMS	C. A. SEUBERT	J. DEFRENES
C. COHEN	B. BLUMBERG	H. J. MAIRE
F. J. BETTELLI	C. PRESRAVE	G. L. DIMMICK

Publicity

J. HABER, *Chairman*

S. HARRIS	P. A. MCGUIRE
J. J. FINN	F. H. RICHARDSON

Convention Projection

H. GRIFFIN, *Chairman*

M. C. BATSEL	H. BLUMBERG	E. O. WILSCHKE
M. LEWIS	H. WALTERS	W. J. CHARLES
C. W. TREEN	F. HOHMEISTER	A. B. FREEMAN

Officers and Members Projectionists Local 310, IATSE

Banquet and DanceM. C. BATSEL, *Chairman*

H. BLUMBERG

E. W. KELLOGG

B. BLUMBERG

W. J. CHARLES

H. WALTERS

A. B. FREEMAN

E. O. WILSCHKE

O. F. NEU

C. W. TREEN

Ladies' Reception CommitteeMRS. O. F. NEU, *Hostess**assisted by*

MRS. M. C. BATSEL

MRS. E. O. WILSCHKE

MRS. H. BLUMBERG

MRS. C. W. TREEN

MRS. A. B. FREEMAN

MRS. B. BLUMBERG

MISS L. A. MOYER, *Social Director*, Chalfonte-Haddon Hall**Headquarters**

Headquarters.—The headquarters of the Convention will be the Chalfonte-Haddon Hall, where excellent accommodations have been assured, and a reception suite will be provided for the Ladies' Committee.

Reservations.—Early in March room reservation cards will be mailed to members of the Society. These cards should be returned as promptly as possible in order to be assured of satisfactory accommodations.

Hotel Rates.—Special rates have been guaranteed by the Chalfonte-Haddon Hall to SMPE delegates and their guests. These rates, European plan, will be as follows:

Four Lower

	<i>Floors</i>	<i>Ocean View</i>	<i>Ocean Front</i>
Room for one person	\$ 3.50	\$ 4.00	\$ 5.00
Room for two persons	6.00	7.00	8.00
Parlor Suite, for one	10.00	12.00	14.00
Parlor Suite, for two	14.00	16.00	18.00

(All bathrooms at Haddon Hall have hot and cold running fresh and salt water)

If American plan rates are desired the hotel room clerk should be advised accordingly when registering. An additional charge of \$3 per day per person will be added to the above-listed European rates for three daily meals, American plan. Members and guests registering at the hotel on the American plan will pay only \$3 for the SMPE banquet scheduled at Haddon Hall on Wednesday evening, April 24th. If registered on the American plan, the clerk at registration headquarters should be advised accordingly when procuring your banquet tickets.

Parking.—Parking accommodations will be available to those who motor to the Convention at the Chalfonte-Haddon Hall garage, at the rate of 50¢ for day parking or \$1.25 for twenty-four hours. These rates include pick-up and delivery of car.

Registration.—The registration and information headquarters will be located at the entrance of the *Viking Room* on the ballroom floor where the technical and business sessions will be held. All members and guests attending the Convention

are expected to register and receive their badges and identification cards required for admission to all the sessions of the Convention, as well as to several motion picture theaters in the vicinity of the Hotel.

Technical Sessions

The technical sessions of the Convention will be held in the *Viking Room* of the Hotel. The Papers Committee plans to have a very attractive program on papers and presentations, the details of which will be published in a later issue of the JOURNAL.

Luncheon and Banquet

The usual informal get-together luncheon will be held in the *Benjamin West Room* of Haddon Hall on Monday, April 22nd, at 12:30 p.m. The forty-sixth Semi-Annual Banquet and Dance of the Society will occur on the evening of Wednesday, April 24th, in the *Rulland Room* of Haddon Hall—an evening of dancing and entertainment for members and guests.

Ladies' Program

A specially attractive program for the ladies attending the Convention is being arranged by Mrs. O. F. Neu, *Hostess*, and the Ladies' Committee. A suite will be provided in the Hotel where the ladies will register and meet for the various events upon their program. Further details will be published in a succeeding issue of the JOURNAL.

Entertainment

At the time of registering, passes will be issued to the delegates of the Convention admitting them to the *Apollo* and *Strand* Theaters, by courtesy of Weilland and Lewis Theaters, Inc., and the *Stanley* and *Virginia* Theaters, courtesy of Warner Bros. Theaters. These theaters are in the vicinity of the Hotel.

Atlantic City's boardwalk along the beach offers a great variety of interests, including many attractive shops and places of entertainment.

W. C. KUNZMANN,
Convention Vice-President

SOCIETY ANNOUNCEMENTS

ATLANTIC COAST SECTION MEETING

At a meeting of the Section held on February 14th at the Hotel Pennsylvania, New York, Messrs. P. C. Goldmark and J. N. Dyer of the Television Engineering Department of Columbia Broadcasting System presented a paper dealing with "Quality in Television Pictures."

Present television standards specify certain factors that determine the appearance of a television picture only to a limited extent. Other factors, however, such as contrast, gradation, brilliance, and the shape of the scanning spot are fully as important and were discussed by the speakers.

A photographic method of producing artificial pictures that permits varying several of these factors, was explained, and pictures were shown which were obtained by this method and which approach ideal quality within a given set of standards.

The next meeting of the Section will be held on March 14th at RCA Photophone Studios, 411 Fifth Avenue, New York. Mr. C. H. Cartwright of Massachusetts Institute of Technology will present a paper dealing with the new types of coatings applied to lenses to improve the optical qualities. The presentation will be accompanied by demonstrations.

MID-WEST SECTION

On January 26th, at a meeting held at the meeting rooms of the Western Society of Engineers, Chicago, the technical staff of the Bell & Howell Company presented a paper on the "Care and Maintenance of Motion Picture Lenses."

On February 27th, Mr. W. C. Kalb of the National Carbon Company, Cleveland, presented a paper entitled, "Projection Light—Then and Now."

Both meetings were well attended and interesting discussions followed the presentations.

INTER-SOCIETY COLOR COUNCIL

At the beginning of this year, the Society of Motion Picture Engineers became affiliated with the Inter-Society Color Council, in the capacity of a Member Society. The SMPE is represented on the Council by Messrs. G. F. Rackett, R. M. Evans, and F. T. Bowditch. Mr. Rackett is Chairman of the SMPE Color Committee. Mr. Evans is Chairman of the delegates to the ISCC.

A meeting of the ISCC Executive Committee was held at New York on February 20th, at which Mr. Evans was present. Reports of the activities of the ISCC will be rendered and will appear in the JOURNAL from time to time. Members of the Society who are interested in presenting problems dealing with color, or who would like to receive information from the ISCC on specific problems, are invited to communicate with Mr. Evans, care of the general office of the Society.

ADMISSIONS COMMITTEE

At a recent meeting of the Admissions Committee at the General Office of the Society, the following applicants for membership were admitted to the Associate grade:

- ALEXA, F. W.
145-30 Brinkerhoff Avenue,
Jamaica, N. Y.
- BRAND, P. L., II
401 N. Piedmont Street,
Arlington, Va.
- EYLES, E. D.
Kodak, Ltd.,
The Works,
Wealdstone,
Harrow,
Middlesex, England.
- GUFFANTI, A.
2995 Marion Avenue,
New York, N. Y.
- HOAR, H. G.
RCA Photophone, Ltd.,
Electra House,
Victoria Embankment,
London, W. C. 2, England.
- KANEKO, G.
Kodak Japan, Ltd.,
Central P. O. Box 247,
Osaka, Japan.
- KELLEY, L. H.
Aeneas Hall,
University of Southern Calif.,
Los Angeles, Calif.
- KINGSLAKE, R.
Hawk-Eye Works,
Eastman Kodak Company,
Rochester, N. Y.
- MANDLEBAUM, D.
651 W. Robinwood Street,
Detroit, Mich.
- MCQUARRIE, A. M.
11148—85th Avenue,
Edmonton,
Alberta, Canada.
- O'DELL, H. J.
203 Hawes Lane,
W. Wickham,
Kent, England.
- PELLY, E. P. L.
Merton Park Studios, Ltd.,
269 Kingston Road,
Merton Park,
London, S. W. 19, England.
- ROBBINS, A.
155 West 20th Street,
New York, N. Y.
- SHIELDS, E. A.
Eastman Kodak Company,
Rochester, N. Y.
- SMITH, H. B.
Cat Rock Road,
Cos Cob, Conn.
- SOFIA, G. V.
909 Avenue P,
Brooklyn, N. Y.
- WESTENFELD, G. H.
126 College Place,
Ypsilanti, Mich
- YORKS, K. P.
160 Beverly Road
Syracuse, N. Y.

JOURNAL

OF THE SOCIETY OF

MOTION PICTURE ENGINEERS

Volume XXXIV

April, 1940

CONTENTS

	<i>Page</i>
The Adjustable Equalizer as a Tool for Selecting Best Response Characteristics..... E. S. SEELEY	351
Solution Agitation by Means of Compressed Air..... C. E. IVES AND C. J. KUNZ	364
Effect of Aeration on the Photographic Properties of Developers J. I. CRABTREE AND C. H. SCHWINGEL	375
The Epoch of Progress in Film Fire Prevention.. A. F. SULZER	398
New Motion Picture Apparatus Safeguarding Theater Sound Equipment with Modern Test Instruments..... A. GOODMAN, R. J. KOWALSKI, W. F. HARDMAN, AND W. S. STANKO.....	409
Officers and Governors of the Society.....	424
Committees of the Society.....	427
Current Literature.....	433
1940 Spring Convention at Atlantic City, N. J., April 22nd to 25th.....	436
Abstracts of Papers for the Atlantic City Convention.....	439
Society Announcements.....	451

JOURNAL OF THE SOCIETY OF MOTION PICTURE ENGINEERS

SYLVAN HARRIS, EDITOR

Board of Editors

J. I. CRABTREE, *Chairman*

A. N. GOLDSMITH

A. C. HARDY

T. E. SHEA

J. G. FRAYNE

L. A. JONES

G. E. MATTHEWS

E. W. KELLOGG

Subscription to non-members, \$8.00 per annum; to members, \$5.00 per annum, included in their annual membership dues; single copies, \$1.00. A discount on subscription or single copies of 15 per cent is allowed to accredited agencies. Order from the Society of Motion Picture Engineers, Inc., 20th and Northampton Sts., Easton, Pa., or Hotel Pennsylvania, New York, N. Y.

Published monthly at Easton, Pa., by the Society of Motion Picture Engineers.

Publication Office, 20th & Northampton Sts., Easton, Pa.

General and Editorial Office, Hotel Pennsylvania, New York, N. Y.

West Coast Office, Suite 226, Equitable Bldg., Hollywood, Calif.

Entered as second class matter January 15, 1930, at the Post Office at Easton, Pa., under the Act of March 3, 1879. Copyrighted, 1940, by the Society of Motion Picture Engineers, Inc.

Papers appearing in this Journal may be reprinted, abstracted, or abridged provided credit is given to the Journal of the Society of Motion Picture Engineers and to the author, or authors, of the papers in question. Exact reference as to the volume, number, and page of the Journal must be given. The Society is not responsible for statements made by authors.

OFFICERS OF THE SOCIETY

- * *President*: E. A. WILLIFORD, 30 East 42nd St., New York, N. Y.
- * *Past-President*: S. K. WOLF, RKO Building, New York, N. Y.
- * *Executive Vice-President*: N. LEVINSON, Burbank, Calif.
- ** *Engineering Vice-President*: D. E. HYNDMAN, 350 Madison Ave., New York, N. Y.
- * *Editorial Vice-President*: J. I. CRABTREE, Kodak Park, Rochester, N. Y.
- ** *Financial Vice-President*: A. S. DICKINSON, 28 W. 44th St., New York, N. Y.
- * *Convention Vice-President*: W. C. KUNZMANN, Box 6087, Cleveland, Ohio.
- * *Secretary*: J. FRANK, JR., 356 W. 44th St., New York, N. Y.
- * *Treasurer*: R. O. STROCK, 35-11 35th St., Astoria, Long Island, N. Y.

GOVERNORS

- * M. C. BATSEL, Front and Market Sts., Camden, N. J.
- * J. A. DUBRAY, 1801 Larchmont Ave., Chicago, Ill.
- ** A. N. GOLDSMITH, 580 Fifth Ave., New York, N. Y.
- ** H. GRIFFIN, 90 Gold St., New York, N. Y.
- * P. J. LARSEN, 29 S. Munn Ave., East Orange, N. J.
- * L. L. RYDER, 5451 Marathon St., Hollywood, Calif.
- ** A. C. HARDY, Massachusetts Institute of Technology, Cambridge, Mass.
- * H. G. TASKER, 14065 Valley Vista Blvd., Van Nuys, Calif.

* Term expires December 31, 1940.

** Term expires December 31, 1941.

THE ADJUSTABLE EQUALIZER AS A TOOL FOR SELECTING BEST RESPONSE CHARACTERISTICS*

E. S. SEELEY**

Summary.—That the problem of manipulating the response characteristics of sound reproducing systems in theaters has been significant is attested by the current practice of equipment companies of providing a variety of response adjustments as part of their standard equipments. However, prior to the establishment of this practice several thousand installations had been made. Continuation of the use of those systems presents a service organization with the problem of determining as expeditiously as possible the optimum response characteristic in specific cases.

The paper which follows describes the design of an adjustable equalizer system to permit selecting quickly, through dial switch adjustments at the listening point in the auditorium, any one of some twenty billion theoretically possible response characteristics. The paper describes the circuits employed and sets forth the reasons which underlie the choice of particular configurations. The accompanying illustrations show the several generalized types of component curves from which the overall insertion effect of any combination of settings may be predicted. For each of the types of sound systems most commonly encountered the method of insertion and the considerations governing the insertion of the adjustable equalizer are given. The paper concludes with a brief discussion of the types of problems whose solution has been facilitated through the availability and use of the adjustable equalizer.

The necessity of manipulating the frequency response characteristic of theater reproducing systems arises in connection with two types of problems. The first type involves the determination of the best characteristic for a given type of horn system. The result of this determination forms the basis for the design of that system's standard corrective networks. The second type of problem involves correcting some aggravated deficiency of quality in a particular theater. Such theaters are essentially non-conformists, since practice that is successful in most theaters having the given type of system fails to produce satisfactory quality in the problem case. The result of the work in such instances is a special equalizer, provided the

* Presented at a meeting of the Atlantic Coast Section at New York, N. Y., Dec. 13, 1938; revised manuscript received Aug. 30, 1939.

** Altec Service Corp., New York, N. Y.

trouble proves to be of such nature that a carefully selected frequency characteristic corrects it.

The first type of problem warrants careful exploration of possibilities since care in selecting a standard curve is rewarded by successful application in many installations. Thorough study in this connection implies, in addition to a proper variation of types of auditoriums and recordings, that a wide range of characteristic variability must be available; the more readily the variations may be produced, the more confident the engineer will be that he has chosen the best solution.

It is the obligation of a servicing organization to make every effort to obtain for the theaters serviced the best quality the reproducing equipment makes possible. In applying this underlying principle to equipments of early design, which embrace the majority of theater sound installations, the first type of problem has been encountered.

Installations which present the second type of problem, that is, the non-conformists, may be divided quite conveniently by the writer of a paper into two classes: those which can, and those which can not be corrected by some variation from the standard response characteristic. Unfortunately, when confronted with a particular case an engineer often finds it a difficult matter to determine into which classification the case falls.

If it is assumed that the trouble is one which a variation in the response will correct, the usual procedure is to set up some characteristic as a starting point; formulate, from a sufficient amount of listening to selected test material, a judgment of the changes in characteristic which may effect the desired improvement; determine how these changes may be accomplished electrically by available adjustments or by the addition of new elements; effect the circuit modification; make the aural test again; and then repeat the cycle over and over until a satisfying solution is obtained. The physical changes are made rather readily when they are confined to equalization steps built into the system, but when such adjustments prove inadequate or are not provided, the engineer attacks the amplifier with a soldering iron and a handful of resistors and condensers. He estimates what elements at some selected point in the amplifier will have about the right effect; makes the change; runs a response curve; finds he missed the mark; changes some of the element values; runs another curve, and then decides he is perhaps near enough to try another aural test. The difficulties that inhere, even under the most favorable conditions, in securing the best result are aggravated by the

length of the period between aural tests, the mounting cost of overtime, and fatigue, all of which greatly impair discrimination.

The principal handicaps to the engineer working on problems of either type in the field may be stated in another way. They are the protracted time between aural tests required to make an electrical change, and failure to bring about the exact electrical change that is desired rather than merely something which more or less approximates it. The effectiveness of these two handicaps produced the desire for a highly adjustable equalizer. The equipment was visualized as a device which could be inserted readily into any reproducing system, and provide controls located at the listening point in the auditorium for instantaneous production of predictable changes in the characteristic over a very wide range. Such an adjustable equalizer system has been built and has proved of great usefulness as an engineering tool.

In planning the response-varying function of the equalizer, it was decided that certain principles must be carried out if the equipment was to have maximum utility. A variety of curve types must be provided of such character and of sufficient diversity to permit, in combination, the production of an insertion curve of any reasonable shape without regard to the predicted requirements of any particular system. This principle precluded the use of available standard equalizers built, with some latitude of adjustment, as components of existing sound systems, and dictated the use of networks which would produce component curves suitable for building up overall curves of almost any type within a reasonable range, that is, exempting extreme amplitudes and extreme slopes. Such curves must be capable of variation in amplitude and location on the frequency axis. It was also decided that the adjustment should be in definite steps and of a kind that would permit the operator of the device to visualize the overall curve he is setting up or to set a curve already visualized.

Nine adjustable equalizer sections were provided, of which eight give functionally different curves and one a duplicate. These curve types are given the following descriptive labels: Low-Frequency Rise, Low-Frequency Droop, Low-Frequency Cut-Off, Mid-Frequency Peak, Mid-Frequency Dip, High-Frequency Rise, High-Frequency Droop, High-Frequency Cut-Off No. 1, High-Frequency Cut-Off No. 2.

The High-Frequency Rise and Low-Frequency Droop curves shown in Fig. 1 are similar in form, but the selector switches manipu-

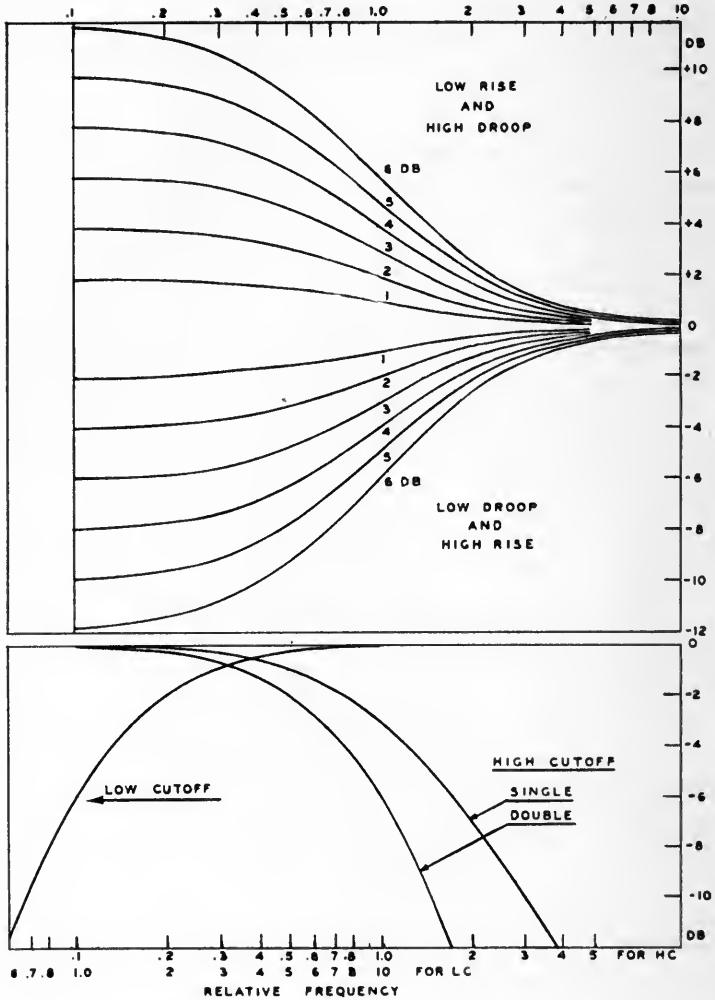

FIG. 1. Generalized relative response of equalizer sections which raise or depress one end of the spectrum.

late them about at opposite ends of the spectrum. A curve of given amplitude and at a given location on the frequency axis is designated on the selector switch dials in terms of the frequency at which the curve has half its ultimate amplitude, and the amount of

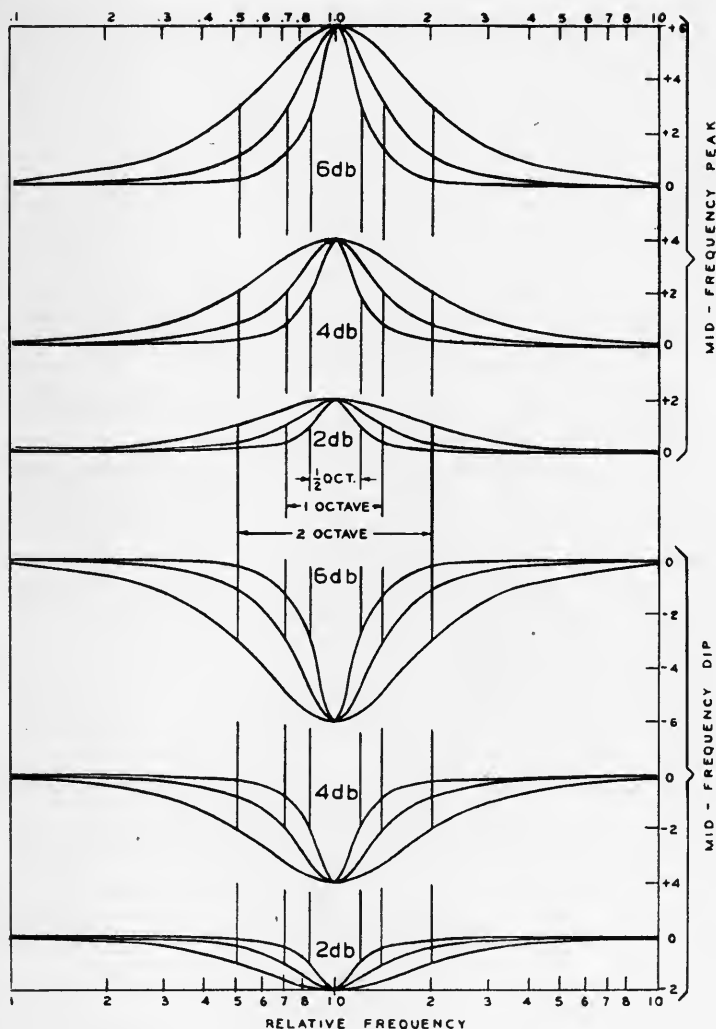

FIG. 2. Generalized relative response of equalizer sections which raise or lower a limited portion of the spectrum.

this half amplitude. Thus a particular curve may be labeled *LD 4 db @ 100*, indicating a curve having an overall amplitude of 8 db and an amplitude of 4 db at 100 cps. The slope of the curve is greatest at the indicated frequency. The curves as shown are drawn on a

"relative frequency" scale, with their mid-points at 1.0. To locate them on a frequency scale for interpretive purposes their abscissas may be multiplied by the selected center frequency.

The High Droop and Low Rise curves also shown on Fig. 1 are the inverse of the preceding curves, and are designated as to amplitude and mid-point location in a similar manner.

The High Cut-Off curves are labeled with the frequency of 3-db attenuation and attain an ultimate slope of 6 db per octave. Two such sections are independently available, and when both are used at the same setting the equalization afforded by the combination at the indicated frequency is 6 db and the ultimate slope is 12 db per octave. This type of cut-off was recognized as inadequate for some two-way horn systems, but such systems are uniformly provided with low-pass filters which may be cut in or out readily.

Two Low Cut-Off settings of a 12-db-per-octave curve were incorporated and are controlled by a switch devoted principally to Low Droop curves.

The Mid-Frequency Peak curve types are shown in Fig. 2. These are typical symmetrical resonance curves and are obtained by a series-resonant four-element two-terminal network designed to vary the curve in amplitude, spread, and frequency of resonance. Amplitudes of 2, 4, and 6 db are available. Spread, which is defined quantitatively as the ratio of the two frequencies at which the curve has half its maximum value, may be set at $1/2$, 1, and 2 octaves. The curves may be centered at any one of eleven frequencies distributed at fairly equal intervals from 200 cps to 5000 cps. By connecting an external decade condenser box to a pair of terminals provided, the peak may be placed at any frequency from 150 to 8000 cps with little departure from the indicated amplitude and spread. For these curves as for all the others, the settings provided result in curves which, within small tolerances, conform with the curves shown in Fig. 2. The half-octave 6-db combination is not available due to limitations resulting from the Q of the coil used.

The Mid-Frequency Dip is the inverse of the peak. This network is similar to the Peak network but is connected across rather than in series with the circuit. The curves given by this section are similar to the Mid-Frequency Peak curves, and similar combinations of amplitude and spread are available plus the 6-db $1/2$ -octave combination.

The insertion characteristic of any section is almost completely

TABLE I

Switch Settings

Low Rise Db	Low Rise Freq.	Low Droop Db	Low Droop Freq.	MF Peak Freq.	MF Dip Freq.	High Rise Db	High Rise Freq.	High Droop Db	High Droop Freq.	High Cut-Off No. 1 Freq.	High Cut-Off No. 2 Freq.
1	225	1	225	200	200	1	1000	1	1000	1000	1000
1	450	1	450	285	285	1	1500	1	1500	2000	2000
1	1000	1	1000	415	415	1	2500	1	2500	3000	3000
2	100	2	100	550	550	1	4000	1	4000	4000	4000
2	225	2	225	650	650	2	1500	2	1500	5000	5000
2	450	2	450	1000	1000	2	2500	2	2500	6000	6000
2	1000	2	1000	1750	1750	2	4000	2	4000	8000	8000
3	50	3	50	2250	2250	3	1000	3	1000	10000	10000
3	100	3	100	2750	2750	3	1500	3	1500	12000	12000
3	225	3	225	3500	3500	3	2500	3	2500		
3	450	3	450	5300	5300						
4	50	4	50								
4	100	4	100								
4	225	4	225								
4	450	5	50								
5	50	5	100								
5	225	6	Low Cut-Off								
5	450	6	45								
6	100	6	50								

MF Peak and MF Dip Amplitudes: 2, 4, and 6 db.
 MF Peak and MF Dip Spreads: 1/2, 1, and 2 octaves.
 Exception: MF Peak 6-db 1/2-octave not available.

independent of the settings of adjacent sections and, as a result, the sections may be combined and the result visualized without running a response curve. Even when the curves from several sections overlap over an appreciable frequency range, the combined curve may be visualized readily, although examination of the generalized curves is necessary to permit accurate prediction.

The switch settings listed in Table I represent the various curves available. While the adjustments permit 20 billion combinations, obviously, many of these probably would never be found useful. Although the adjustment range was considered adequate for all ordinary requirements, an adjustment is occasionally desired that is outside the range provided. To accommodate such unusual requirements, terminal posts have been included in three of the sections for external connection of adjustable resistance, capacity, or both. We provide for this purpose a decade condenser box having a range from $0.0001 \mu f$ to $10 \mu f$ and an indicating tapered rheostat of broad range.

Loss in volume level results when some of the equalizer settings are switched in and may be compensated by the level control. In general, High Rise and Low Rise cause a mid-range loss equal to the overall amplitude of the curve although this generalization is subject to some qualification if the curve extends into the range that determines volume level of speech. High and Low Droop and the cut-offs have no important effect on volume level unless the curve extends to the voice-volume region. The MF Peak set outside the voice-volume region produces a loss somewhat greater than the amplitude of the curve, depending upon the selected combination of amplitude and spread. The MF Dip produces only a small loss unless it is located in the volume-determining range.

The matter of phase distortion was considered early in the design of the equalizer system. The use of equalizers which introduce no phase delay was impracticable. Consideration was given to including several adjustable phase-delay sections for experimental purposes but space was not available within the dimensions to which we wished to confine the control unit. In general, the equalizer networks employed in this system are of the types which would be used to equalize a system permanently to the curve found desirable by the adjustable equalizer, and therefore one may expect the equalization permanently installed to produce the same results, including any changes in phase characteristic, as were obtained with the variable equalizer.

The equipment consists of a booth unit, a control unit located in the

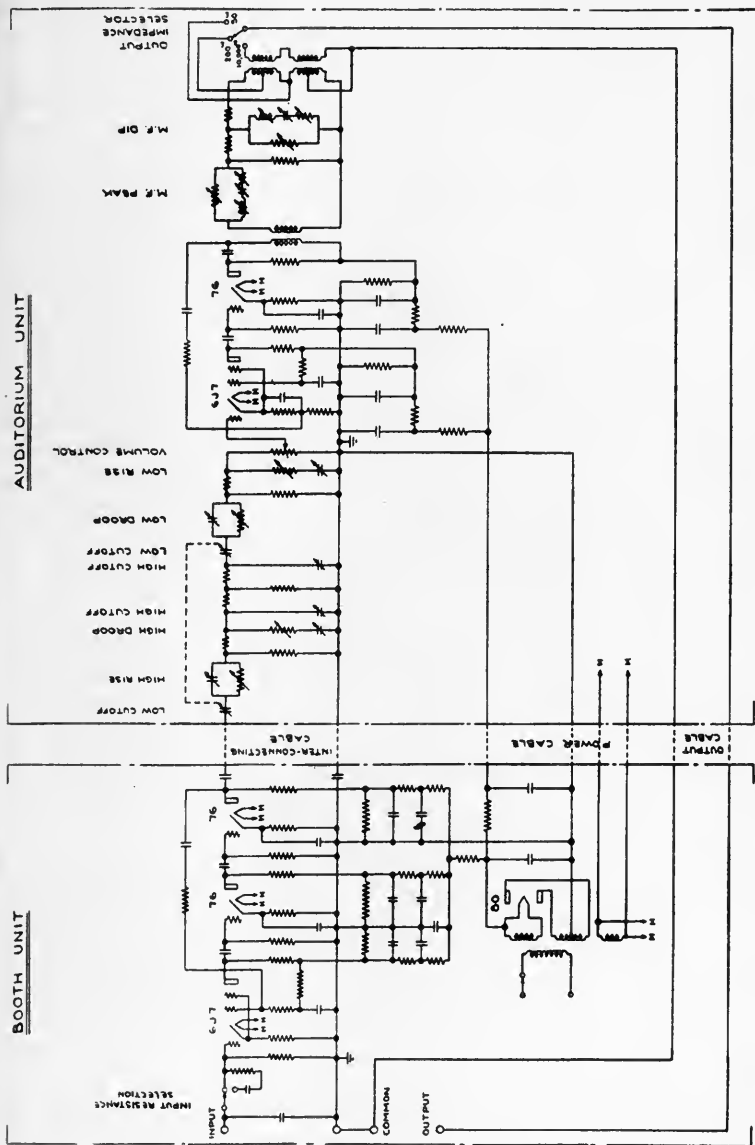

Fig. 3. Schematic of the adjustable equalizer system as constructed for field use.

auditorium, and interconnecting cables. The booth unit consists of an amplifier and power unit. The control unit contains the equalizer sections, an amplifier, volume control, output transformer, and output impedance selector switch. Three cables 100 feet long are required: two for speech, and one for power services for the control unit amplifier. The entire schematic arrangement is shown in Fig. 3.

The total amplification is divided into two parts. The first is placed ahead of the line to the auditorium in order that the signal transmitted may be of relatively high level to minimize danger of noise pick-up in this run. After a considerable loss is sustained from a number of equalizer sections, the second amplifier raises the signal level again for further equalization and the return to the booth and the system amplifier.

The booth unit amplifier has three stages, resistance coupled, to deliver a maximum level of 0 db relative to 0.006 watt. Feedback is employed to reduce harmonics generated in the second two stages and to reduce the output terminal impedance in order to minimize the effect of the capacity of the long shielded cable. A power unit having a high degree of filtering is included to permit a-c operation. The control unit amplifier consists of two stages embraced by a feedback loop.

For the equalizer sections design selection was available between two-terminal and four-terminal networks. With four-terminal constant-resistance networks, the characteristic of one section is independent of the setting of the adjacent sections without the necessity of isolation by intervening loss sections. Such networks, however, require double the number of elements, coils must be used in each section, and the result is a much larger, heavier, and more costly assembly. Further difficulties result from the necessity of procuring a large variety of coils having correct inductance and Q over the required range of frequencies. For these reasons two-terminal networks were chosen. The requirement of increased amplification to compensate for the loss in the isolating pads required between such sections was not regarded as a serious objection, since an amplifier is required in any event to compensate for the loss in either type of network.

The point at which the equalizer system is inserted in the theater system varies with the type of system. In those systems which contain a low-impedance, low-level circuit, the equalizer is inserted at such a point, usually following the change-over device. Thus in most

Western Electric and Motiograph Mirrophonic systems it is inserted between the fader and the main amplifier. In Simplex Four-Star systems, it is inserted just ahead of the main amplifier. In RCA Photophone systems it may be inserted in the low-impedance circuit if there is one, between sound-heads and main amplifier, and when this circuit is balanced to ground, it is temporarily changed to an unbalanced circuit. Photophone systems not having the low-impedance linkage are easily accommodated by removing the grid-cap connection from the first tube and inserting the variable equalizer between the grid lead and the grid of the tube. Experience with a large variety of sound systems has revealed none to which the equalizer can not be readily adapted.

Two limiting conditions must be kept in mind:

(1) Input voltage levels exceeding -50 db relative to 1.73 volts require the use of the low-gain position of the input switch to avoid overloading the first amplifier.

(2) The output hum level of the equalizer system is -100 db and in systems which do not have preliminary amplifiers the noise level begins to be disturbing if the amplifier has a gain of the order of 90 db.

Considerable field experience has been accumulated through the use of this equalizer. The main handicap confronting an engineer in his attempt to obtain the most suitable response characteristic, namely, the difficulty inherent in achieving desired changes, is eliminated. The time, effort, and ingenuity otherwise so expended are profitably employed in attacking other phases of the problem. The significance attaching to the presence in the past of this manipulation handicap is emphasized by a brief review of instances on record. The record shows that in extreme cases, thoroughly experienced and qualified engineers spent from one to three weeks in a single theater before their conviction was established that the quality imperfection whose cause they sought was of such nature as not to be subject to correction by response characteristic manipulation. There have been cases, also costly to both the exhibitor and installation organizations, where a quality deficiency was assigned to causes other than response characteristic. Stage equipment was replaced, relocated, draped, or redraped to no avail. Subsequent trial showed the solution to reside in proper selection of the response characteristic.

Certain types of distortion give rise to a conviction on the part of the engineer that correction must necessarily follow upon his making appropriate changes in response. Some problem houses can not be

so compensated. The application of the adjustable equalizer to these problems quickly and convincingly proves the point. A pertinent illustration involved a house obviously wholly deficient in bass response although identical equipment in many other theaters provided adequate bass easily made excessive through additional low-end equalization. It quickly was found in the house under discussion that no practicable amount of low-frequency reinforcement of the characteristic produced a noticeable effect upon the acoustic response below 100 cps. It was necessary to seek a "best" compromise between some apparent music bass and "heavy" speech reproduction through reinforcing the range between 100 and 300 cps. The difficulty was assigned to the light wall-construction employed.

There have been instances in which correction of a quality deficiency was effected through response changes in a part of the characteristic not usually associated with the observed deficiency. Such correction was evolved only by virtue of the ease with which changes of almost any conceivable kind could be made and the rapidity with which unsuccessful changes were rejected and others substituted. Such was found to be the case in a theater suffering from lack of "presence" where treatment in the region from 2000 to 3500 cps failed to produce the usual result, and the facility with which changes could be made led to elimination of the defect by reinforcing the 400 to 600 cps range.

An old lesson was re-learned forcibly at the outset of our program of study of and with the variable equalizer. That lesson was that efforts to improve the characteristic of a reproducing system hold promise of success only after the flutter content of the film propulsion mechanism has been reduced, where the chief component is 96-cycle modulation, to a value of the order of 0.4 or below. The effect produced by such flutter frequently is misinterpreted as resonance peaks in the 1500 to 3000 cps range. The *TA-7421* flutter bridge, with which our field forces were equipped in 1936, affords a ready means for determining the flutter performance. Consequently, determination of the percentage of flutter present always precedes our use of the adjustable equalizer.

The equalizer already has been used on sound systems of a variety of makes and types in many theaters. It has been used also in connection with the setting up of a binaural public address system, a synthetic sound system, and a high-quality disk reproducing system set up in a theater for a special demonstration, under the direct super-

vision of the conductor, of recordings of an outstanding symphony orchestra. It is interesting to note that in the last case mentioned the equalization set up by the sound engineers was changed substantially by the conductor chiefly to tone down the strings and to build up the bass instruments to a dominance admittedly greater than that in the original playing of the orchestra.

The listing of applications already found for the equalizer outside the specific purpose for which it was designed is evidence of the equalizer's versatility and assures its permanence as a useful tool for sound technicians.

SOLUTION AGITATION BY MEANS OF COMPRESSED AIR*

C. E. IVES AND C. J. KUNZ**

Summary.—Agitation of the developing bath by means of compressed air or other gas is most effective when the upward stream of air bubbles is made to follow the surface of the film. When the air is released at the bottom of the tank, the induced stream usually passes up through one portion of the tank without reaching all parts of the film. The stream can be made to follow the surface of the film in a vertical rack type developing machine by the use of an air distributing gridwork which discharges the air at a large number of points distributed along the film strands from bottom to top of the rack.

In the course of photographic development, that portion of the developing bath which is absorbed by the emulsion becomes altered by the depletion of its active ingredients and the accumulation of reaction products. This partially exhausted developer within the emulsion has a lower reaction rate and must be replaced constantly by diffusion from the relatively unaffected developing solution adjacent to the emulsion surface. This solution, in turn, is renewed by means of developer brought to this region from the main body of the liquid in the containing vessel. The rate of renewal of developer within the emulsion by diffusion may be limited by the unavailability of fresh solution at the emulsion surface¹ but such a limitation would not be harmful if its effect were uniform over the whole emulsion surface. Unfortunately, this is not the case and some very undesirable effects occur unless steps are taken to prevent them. In general, the unevenness of development of different areas results in differing densities at points which have received equal exposures. In a large area which has had a uniform exposure a mottled or streaky appearance is evident. Exhausted developer accumulating near a high density area of considerable size may stream out over an adjoining area causing a diminution in density.

When the developer in the neighborhood of the film receives little agitation other than that resulting from the unidirectional motion of

* Presented at the 1938 Spring Meeting at Washington, D. C.; revised manuscript received March 18, 1940.

** Kodak Research Laboratories, Rochester, New York.

the film, well-defined streaks may be seen trailing away from high-density areas in a direction opposite that of the film movement during processing. The manner in which this condition affects sound records and sensitometric exposures arranged in the usual stepwise fashion has been studied by Crabtree and later by Crabtree and Waddell.² In this connection they used the term "directional effects." The present work is concerned with improvement in development uniformity beyond the point where serious directional effects are shown in sensitometer tests.

Several methods of promoting the renewal of the solution at the emulsion surface are possible, namely, (a) passing the film through the machine at high speed, (b) circulation of the developer by means of pumps and impinging the liquid against the film surface by means of jets, and (c) bubbling gases through the solution. No attempt is made in this paper to compare the effectiveness of the various methods, the following data being restricted to the gas method of agitation.

Stirring by Means of Gas Bubbles.—The use of compressed air or other gases for the agitation of liquids ordinarily consists in releasing the gas bubbles in a stream at one or more points at the bottom of a vessel, from which point they rise through the body of the liquid and are released into the air at the surface. This method has had considerable use in chemical processes and has been used to some extent in motion picture work in the rack-and-tank process. Stirring by this means was particularly helpful in the Gaumont type continuous developing machine where the solution was contained in narrow vertical tubes. In these tubes, which were from 2½ to 5 inches in diameter and as long as 6 feet, the stream of gas bubbles was, of necessity, constrained to follow a path where it agitated the liquid in contact with the film. Agitation by gas streams has apparently had little application to the present-day vertical rack developing machine. One reason for this may be the difficulty in controlling the direction of the stream in a tank of large cross-section.

In order to avoid oxidation of the developer, nitrogen gas has been used to a limited extent but its use is expensive and, in many cases, unnecessary. With most developers the chemical effect of air used for agitation is hardly severe enough to raise any serious objection on the basis either of undesirable photographic effects or increased replenishing cost.³ In the present work only compressed air was used.

Air Agitation in a Vertical Rack Developing Machine.—In order to study the action of air agitation in a developing machine, a special

tank was constructed of transparent Eastman acetate sheet by the method described by Hickman and Hyndman.⁴ The support required to keep the tank in shape when full was furnished by an open-work wooden frame as shown in Fig. 1. This tank, representing one



FIG. 1. Transparent tank illuminated from the rear. Racks and vertical grid distributors in position.

unit in a 30 to 40-feet per minute vertical rack type continuous processing machine, was intended to accommodate two racks. It had inside dimensions of $5\frac{1}{4}$ by $13\frac{1}{4}$ by $35\frac{1}{2}$ inches deep. The tank was filled with water. Racks, cooling coils, *etc.*, were introduced from time to time as required.

Method of Observation.—It was found convenient to view the movement of airbells in the tank with the aid of illumination from one of the large sides. Viewed from the opposite side, bubbles in the liquid appeared somewhat darker than the bright surrounding field. Under these conditions, air bubbles released singly from the bottom of the tank were clearly visible in their course to the top surface of the liquid. Motion pictures made at rates up to 64 frames per second with this same illumination were found helpful in studying detailed patterns of movement of the airbells and for measurement of the rate of streaming. In order to determine the rate of bulk movement of the liquid in the tank carried along by the airbell stream, observations were made by introducing potassium permanganate solution into the tank at a suitable point.

Movement of Air Bubbles of Various Sizes.—It was found that air bubbles of varied size would be discharged through orifices in a rubber tubing made by cutting it with a point or chisel edge. At a low rate of flow, the large size bubbles ($\frac{1}{4}$ inch in diameter) were absent. However, smaller bubbles were present even at comparatively high rates ($1\frac{1}{2}$ cubic feet per minute discharging from 20 slits $\frac{1}{4}$ inch in length). By the use of glass or metal tubes with orifices of fixed size, the smaller bubbles ($\frac{1}{16}$ inch and smaller) were largely eliminated and the range of sizes was rather narrow at any one rate of air discharge. The size of the bubbles could be increased somewhat by increasing the rate of flow and the size of the orifices.

By discharging bubbles into the water at the bottom of the tank, singly or a few at a time, the dependence of the rate of bubble movement upon bubble size was observed. Starting with bubble sizes which were almost microscopic, the rate of movement to the surface was very slow. When a strong flow of bubbles comprising a mixture of sizes, including the very small, had been passing through the tank for several minutes and was then stopped, the larger ones would disappear in a matter of a few seconds while the cloudiness resulting from the presence of numerous small bubbles would not be cleared away until several minutes had passed. The very small bubbles contributed negligibly to the stirring of the developer and, therefore, were undesirable. As the bubble size was increased, the rate of rise of single bubbles through still water was also increased until a velocity of about 1 foot per second was attained. This velocity was observed with bubbles of approximately $\frac{1}{4}$ inch in diameter. Larger sizes had only slightly greater velocity. The individual bubbles larger

than about $\frac{1}{16}$ inch in diameter rose with a quick, staggering motion.

The rate and manner of movement of gas bubbles through a liquid has been the subject of a number of investigations. Many of them have had to do with the case of an elongated bubble having a diameter almost equal to that of a narrow tubular vessel in which the rate of movement was observed. In other cases of more immediate interest where relatively larger vessels were involved, velocities up to 1.3 feet per second were observed.⁵ Some of the investigators found that the bubbles flattened and rocked and traversed helical paths depending on their size and the diameter of the tube. In one case vortex rings were detected in the wake of the larger bubbles.

Unquestionably the liquid near the bubble is moved about greatly. The significance of this is that a generally turbulent condition, which should be very helpful in obtaining uniformity of developer action, prevails throughout the path of a stream of bubbles.

At the top surface of the liquid both vertical and horizontal movements of the liquid are readily observable.

Channel Formation.—When the rate of discharge of bubbles was increased, a general streaming of the liquid along the path taken by the bubbles was set up. Water propelled to the upper part of the tank along this path passed downward through another part of the tank and eventually reentered the ascending stream. As this action continued it was found that even if the airbells were released at numerous points along the bottom of the tank, they tended to run together and form a relatively narrow column or channel. In the tank described, stream velocities within the channel reached a value of about 2 feet per second. At the same time, the movement of liquid downward and, to a certain extent, horizontally, in the remainder of the tank, diminished to practically zero in certain places.

Factors Affecting the Shape and Position of the Channel.—For an extremely low rate of flow of air, where the bubbles rose singly or, at the most, a few at a time, no distinctly recognizable channel existed. The channel formed, however, as soon as a substantial rate of air flow was reached ($\frac{1}{10}$ cubic foot per minute per square foot of total horizontal cross-sectional area of the tank). Since the effect upon development uniformity produced by any less than this flow of air was quite poor, any improvement in air agitation would have to take the channeling tendency into account. As the air flow was increased still further, the channel became more clearly defined (Fig. 2), but the distribution was not improved with the air flow increased to as

much as 3 cubic feet per second per square foot of horizontal cross-section of the tank. The top surface of the liquid was in such a state of strong agitation as to lead to the supposition that the whole contents of the tank were being stirred effectively which was not actually the case as was found by viewing through the tank wall.

Prior to the time of the present work, various arrangements of distributing pipes and plenum chambers made to fit the bottom of the tank had been devised to improve the distribution of the air stream throughout the tank. The principal result of these efforts was to find a type of construction which would maintain equal air streams at the different orifices. This uniformity was best attained by the use of small orifices in rigid corrosion-resisting materials and with air pressures in the distributing pipes substantially greater than the external pressure at the point of discharge.

Tests with Racks in Position.—

With the developing rack and the cooling coils occupying their normal positions in the tank, observations were made of the streaming patterns obtained with an air distributing system consisting of a single metal pipe in which were drilled a number of small orifices. This was located on the bottom of the tank at the mid-line parallel to the longer dimension. With this distributor operating in the normal way, the tendency to channeling was much the same as had been observed in an open tank although the presence of the racks caused a definite change in the position of the stream. Not more than 20 per cent of the film in the tank was subject to the action of the rapidly moving stream. It was evident also that the liquid returning to the bottom of the tank was moving along some of the film strands while a condition approaching stagnation existed near others. The presence of the return path in this portion of the tank was a factor tending to cause the deflection of the much more rapid upstream to one end of the tank.

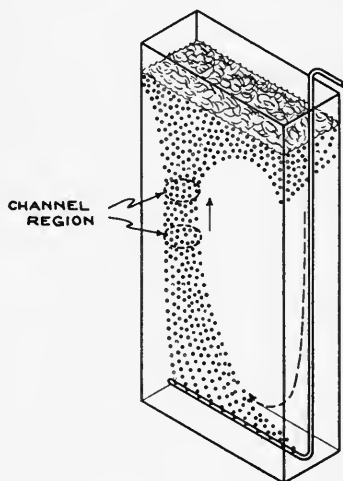

FIG. 2. Path of bubbles rising from a horizontal distributor on the bottom of the tank.

This condition was improved somewhat by providing an additional return path in a portion of the tank beyond the ends of the racks. In order to make a passage into this space, large rectangular apertures were cut into the rack frame at a point near the upper surface of the liquid. Openings were also made in the bottom frame member of the rack so that the liquid after passing downward through the space at the end of the tank and thence along the bottom of the tank could rise vertically through the bottom of the rack. These modifications had the effect of moving the high-velocity channel toward the center of the tank where it came in contact with more film strands.

Effect of Changes in the Distributors.—An effort was made at this point to divide the stream by the provision of three separate distributing tubes, one at the center and one at each side of the tank bottom. Better distribution was obtained at the bottom of the racks but the streams tended to run together toward the top forming the familiar channel. The results were no better when the distributing pipes were placed along the sides of the rack near the lower rack rollers. The location of the orifices in such a way as to deliver the air upward, downward, or horizontally toward the film was found to have little influence in directing the stream. The bubbles were simply released at the orifices and were not projected outward appreciably with the rates of flow employed. While it would have been possible by the use of baffles to prevent the union of the streams originating on each side of the rack, it was preferred not to modify the rack in this manner.

Porous Carbon Distributors.—Another form of air distributor which has been used in electroplating apparatus is of the porous carbon type,⁶ and consists of small particles of carbon held together with a carbon bonding material so that the resulting porous cake consists of 99 per cent carbon.

Distributing units of various degrees of porosity designed to fit into the bottom of the test tank were furnished by the National Carbon Company for trial. Although the size of bubbles and the distribution over the porous surface were quite satisfactory, the use of this type of distributor furnished no control over the tendency to channel in the upper part of the tank.

A Means of Positioning the Channel.—Since the channel, formed spontaneously, continues its existence by reason of the relatively low average density of the mixture of air and water thus formed, it was believed that the shape and position of the channel might be prede-

terminated if a region of reduced density could be established in the required position.

Neglecting that portion of the film which lies in contact with the upper and lower rack rollers, the film in the developing machine lies along a vertical plane on each side of each rack. The channel through which the liquid should pass upward through the tanks would be contiguous to this plane. Thus, the cross-section of the channel might have the dimensions of 1 inch by 6 inches and, in

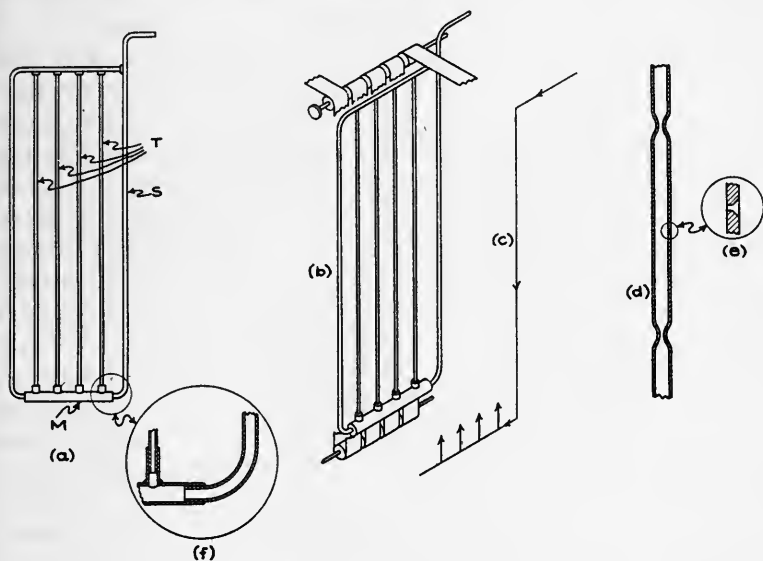

FIG. 3. Details of vertical grid distributor: (a) distributor, (b) position of distributor relative to rack, (c) path of air through distributor, (d) method of introducing additional resistance to flow of air in oversized distributor tubes, (e) orifice in distributor tube, (f) construction details of distributor manifold.

length (vertically), should be equal to the length of the film strands on the side of the rack.

It was found that such a region of reduced density could be formed by discharging small streams of air at a large number of points throughout this region from bottom to top of the rack. Air was delivered to these points by means of a gridwork of small tubes erected near the side of the rack and at a distance of about $\frac{1}{4}$ inch from the film surface (Figs. 1 and 3b). The individual tubes were arranged vertically (Figs. 3, a and b).

The position of the streams or channels was established satisfactorily by this means. The distributing tubes were located on approximately vertical lines so that the film moving by at a small angle, passed a succession of the orifices displaced in small steps from one edge to the other across its width. The general direction of the stream was, of course, at the same small angle to the direction of the film movement but the movement of the developer at any one point was varied in direction because of the turbulent condition of the stream.

Development Uniformity.—Photographic tests were made in the course of these changes by developing motion picture film which had been given a uniform flash. Development was to a degree considerably less than gamma infinity so as to produce a more easily detectable degree of non-uniformity in the lack of adequate agitation. Improvement in uniformity was noted in successive alterations of the circulatory system as described previously. The greatest improvement in a single step occurred when the air agitation was first introduced. The successive modifications, while effecting a necessary degree of improvement, did not have as great an effect. A flow of 1 cubic foot of air (atmospheric pressure) per minute at each side of a rack was found suitable with the grid finally adopted. Under actual working conditions with emulsions developed to their normal gammas, the density variations were small in all cases where agitation was employed. It was attempted to make a graphical representation of density variation by means of a recording densitometer but this type of record was unsatisfactory, apparently because it showed only a profile of density variation along the line of scanning and, therefore, failed to show the whole pattern. Consequently it was necessary to judge results by projection and by viewing over an illuminator. In order to have sufficiently large density variations for judgment by projection it was necessary to "magnify" the variations in the original test sample by making a contrasty print.

In practical processing work of an exacting nature, a degree of uniformity satisfying current standards was obtained. The grid type distributor found helpful in the present case would be useful only in a machine in which the film path was as described above. Best results have been attained when development was followed by the use of an acetic acid stop bath.

Construction of the Air-Distributing Grid.—In a gridwork arranged as shown in Fig. 3, *a* and *b*, the air is discharged from the orifices lo-

cated at 3-inch intervals along the length of the tubes marked *T*. Air is supplied to these tubes from the manifold pipe *M* at the bottom of the grid which, in turn, is connected to the supply tube *S* (Fig. 3a). The tubes receive their physical support from the manifold at the bottom and the horizontal member at the top. These are supported in turn by attachment to the supply tube *S* and a tubular member on the opposite side.

Air is discharged at any particular point in the tank only after the pressure at the inside of the tube exceeds the resisting force outside the aperture which includes the hydrostatic head. Since the head is dependent upon the depth of the liquid, the greatest air pressure is required at the orifices located near the bottom of the tank. For this reason, the air was brought through the supply tube to the bottom manifold and then passed upward as required through the tubes (Fig. 3c). With a total flow of air of about 1 cubic foot per minute (atmospheric pressure) from each gridwork, a supply tube of $1/8$ -inch inside diameter ($3/16$ -inch outside diameter) was found ample. To facilitate welding at the several points on the manifold, this was made of $3/16$ -inch inside diameter material.

Distributing grids were constructed with $1/16$ -inch inside diameter tubing *T* which, by reason of its small size, furnished sufficient distributed resistance to produce the necessary pressure gradient along the length required to compensate for the varying hydrostatic head. At the rate of discharge employed, the pressure gradient in distributing tubes of larger diameter was not sufficient to compensate for the rate of change in hydraulic pressure from bottom to top of the tank. As a consequence, the bulk of the air was discharged at the top of the tube, the lower orifices being ineffective.

If only a larger size of tubing is available, the required additional resistance can be introduced by constricting the tubes as shown in Fig. 3d, thus creating several zones of successively diminishing pressure.

The orifice holes are 0.030 inch in diameter and are made by hand by the use of a hard steel punch. Before the hole is punched the tube wall is thinned down to $1/64$ inch by means of a $1/8$ -inch drill (Fig. 3e).

Stainless steel (18 per cent chromium-8 per cent nickel) tubing in the required sizes is available on special order from the regular sources of supply. The most desirable type of construction consists of welding wherever possible. With the smallest distributing tubes, however, only a flash weld requiring special equipment would be ac-

ceptable. This difficulty was overcome satisfactorily, however, by the adoption of the construction shown in Fig. 3f. Tees are formed by butt welding short lengths of $\frac{1}{8}$ -inch inside diameter tubing to the manifold tube by the usual gas welding procedure, using a high-columbium rod. All openings are inspected and cleared, if necessary, prior to welding the manifold to the supply tube S. Finally, the distributing pipes are inserted into the tees and fastened with a small amount of silver solder. The outside diameter of the distributing tube is almost as great as the inside diameter of the stems in the tee so that only a fine line of the silver solder is exposed to the action of the developing solution (Fig. 3f).

REFERENCES

- ¹ CLARK, W.: "Standard Development," *Phot. J.*, **49** (Feb., 1925), pp. 76-89.
- ² CRABTREE, J.: "Directional Effects in Continuous Film Processing," *J. Soc. Mot. Pict. Eng.*, **XVIII** (Feb., 1932), p. 207.
CRABTREE, J., AND WADDELL, J. H.: "Directional Effects in Sound Film Processing—II," *J. Soc. Mot. Pict. Eng.*, **XXI** (Nov., 1933), p. 351.
- ³ CRABTREE, J. I., AND SCHWINGEL, C. H.: "The Effect of Aeration on the Photographic Properties of Developers," *J. Soc. Mot. Pict. Eng.*, **XXXIV** (April, 1940), p. 375.
- ⁴ HICKMAN, K. C. D., AND HYNDMAN, D. E.: "Plastic Cellulose in Scientific Research," *J. Frank. Inst.*, **207** (1929), p. 231.
- ⁵ MIYAGI, O.: "Theory of the Air-Lift Pump with Special Reference to the Slip of Air Bubbles in Water," *Tech. Reports Tôhoku. Imp. Univ.*, **4**, No. 2 (1924), pp. 1-18. (Discussed in Bull. No. 84, *Nat. Res. Council*, "Hydrodynamics" (1932), p. 304.)
- O'BRIEN, M. P., AND GOSLINE, J. E.: "Velocity of Large Bubbles in Vertical Tubes," *Ind. Eng. Chem.*, **27** (Dec. 1935), p. 1436.
- ⁶ BROADWELL, B. E., AND WERKING, L. C.: U. S. Pat. 1,988,478 (Jan. 22, 1935).
WERKING, L. C.: "Fabricated Porous Carbon," *Trans. Electrochem. Soc.*, **74** (1938), pp. 365-374.
- HATFIELD, M. R.: "Fluid Flow through Porous Carbon," *Ind. Eng. Chem.*, **31** (1939), pp. 1419-1424.

EFFECT OF AERATION ON THE PHOTOGRAPHIC PROPERTIES OF DEVELOPERS*

J. I. CRABTREE AND C. H. SCHWINGEL**

Summary.—The object of this investigation was to ascertain the feasibility of using air as a means of agitating developing solutions by determining the effect of bubbling air through various commercially used developers on their photographic properties.

Unseasoned elon-hydroquinone developers of relatively high alkalinity (pH 10.0 to 10.5) showed a rapid decrease in activity after aeration for 1½ hours while elon-hydroquinone-borax developers of low alkalinity (pH 8.4 to 8.8) showed increased activity (due to the liberation of alkali resulting from oxidation) which then remained constant for prolonged periods.

In general, the alkalinity of developers containing hydroquinone increased on aeration, while those containing only elon showed little change.

Practical tests with processing machines equipped with air agitation devices have shown that very constant developing conditions can be maintained when suitably replenished.

It is well known that many types of photographic developers tend to lose their developing power as a result of exposure to the air. This is especially true in the case of developers containing an appreciable quantity of pyrogallol which change rapidly from colorless to brownish red solutions especially when the temperature is much higher than 70°F.

Developers of the elon-borax type, however, show no visible signs of change under the above conditions but their developing properties are more or less affected.

With hydroquinone developers containing sodium carbonate or caustic soda, and which have been allowed to age in the presence of air, it is necessary to develop for a longer time than with fresh developers in order to secure a given degree of contrast.¹ In 1929, Carlton and Crabtree² discovered that a developer containing borax as the alkali showed increased activity when allowed to age under ordinary conditions. Lüppo-Cramer³ and Rzymkowski⁴ have also

* Communication No. 672 from the Kodak Research Laboratories; presented at the 1938 Spring Meeting at Washington, D. C.; revised manuscript received March 22, 1940.

** Eastman Kodak Co., Rochester, N. Y.

shown that sodium sulfite solutions containing developing agents but without alkali show increased developing action after being subjected to aerial oxidation.

Mees and Piper⁵ encountered aerial oxidation fog with hydroquinone developers and also stated that the oxidation products of pyrogallol, when present in developers, caused fog. Similarly, it was stated by Crabtree⁶ that the oxidation products of developing agents, produced by improper methods of mixing, may cause development fog. This observation was not confirmed in the later work of Dundon and Crabtree⁷ when it was found that the addition of oxidized developer to a fresh developer tended to decrease fog. This inability to produce oxidation fog with existing chemicals was attributed to the fact that chemicals manufactured previous to 1920 which readily gave fog, must have contained impurities which, on oxidation, behaved as powerful fogging agents.

Fuchs⁸ also found that the oxidation of hydroquinone developers by air in contact with an emulsion produced a latent image fog, while the oxidation products in the developer tended to decrease rather than increase fog. He considers that aerial oxidation fog is the result of a latent light image produced by chemi-luminescence which, in turn, is a result of oxidation of the developer in contact with the film. It is more probable, however, that aerial fog is a result of the formation of peroxides which are known to be powerful fogging agents.

In order to obtain uniform development of a photographic image, it is necessary to employ some means whereby fresh solution is constantly applied at the surface being developed, otherwise uneven development is obtained. Probably the simplest procedure for developing short lengths of film or plates is to develop in a shallow open tray. Agitation of the solution is accomplished either by rocking the tray or by brushing the emulsion surface with a camel's hair brush. These conditions are conducive to rapid oxidation owing to the large surface of liquid which comes into contact with the air.

In the case of processing machines in photofinishing establishments, the film wetted with developer is exposed to the atmosphere for at least 10 per cent of the total developing time while, with certain motion picture developing machines, somewhat similar conditions prevail which present ideal conditions for aerial oxidation.

Aerial oxidation also presents serious difficulties when motion picture film is developed on a reel when, due to the prolonged contact of the wet film with air, it is usually necessary either to add a desensi-

tizing dye or an increased quantity of sodium sulfite to the solution in order to prevent aerial fog.

Many motion picture laboratories depend upon the circulation of the developer as a means of agitation and conditions are often such that during recirculation the solution is allowed to overflow into a tank situated on the floor below. This overflowing of frothing developer with entrapped air furnishes excellent conditions for aerial oxidation.

The importance of agitation of the developer in order to obtain uniformly developed images is becoming more fully appreciated.⁹ Of the various possible methods of agitation, the use of a stream of gas bubbles is effective and economical.¹⁰ Nitrogen gas is to be preferred for this purpose, but is expensive.

The object of this investigation was to ascertain the feasibility of using air as a means of agitating developing solutions by determining the effect of bubbling air through various commercially used developers on their photographic properties.

Experimental Methods.—The following data were obtained by the use of a $1\frac{7}{8}$ -inch by 70-inch glass tube closed at one end and mounted vertically for holding the solutions through which the air was bubbled. Two liters of solution were used for each test which filled the tube for about one-half the height, the remaining tube portion serving to prevent loss of solution by spattering and frothing.

The air was passed in at the bottom of the tube and the rate of air flow was approximately 5 cubic feet per hour at a temperature of 72° to 74°F which produced a degree of aeration somewhat more rigid than that which usually occurs in practice. The air employed was filtered and then washed so as to bring it to near saturation and thereby minimize evaporation of the developer liquid. All connections, stoppers, and stop-cocks were of glass so as to eliminate any possible contamination.

On the completion of a bubbling test, the two-liter sample of developer was withdrawn from the tube and used immediately for developing sensitometric strips which had been exposed previously on a Type II*b* sensitometer.¹¹ The temperature during development was maintained at 65°F. When a positive type of developer was being tested, Eastman motion picture positive film (1301) was used and, for a negative type of developer, Eastman motion picture negative film (1217) was employed.

All pH measurements were made on a slide comparator using La-Motte indicators.

Effect of Aeration with an Elon-Hydroquinone Motion Picture Positive Developer.—Fig. 1 shows the effect of prolonged air agitation on an elon-hydroquinone developer (Formula D-16) with respect to (a) the change in density obtained with equal exposures, (b) the change in solution alkalinity, and (c) the emulsion fog density values. Data are included for (a) fresh D-16, (b) partially exhausted D-16 (175 ft per gallon), and (c) D-16 containing double the normal quantity of sulfite.

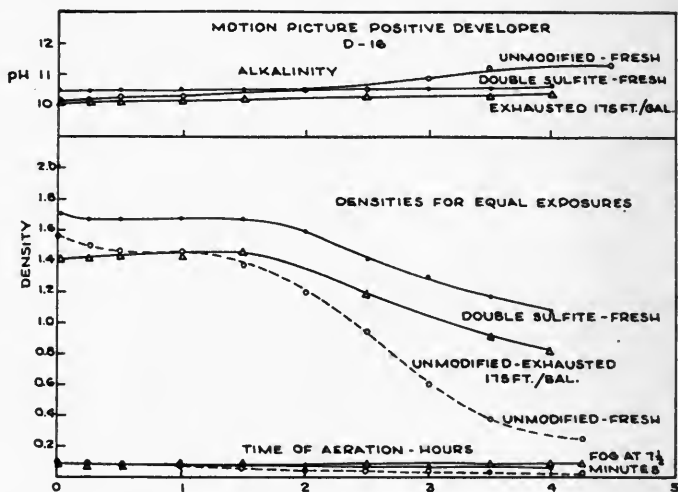
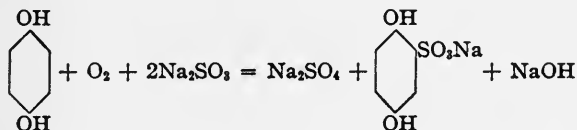

FIG. 1. Effect of prolonged aeration on an elon-hydroquinone developer (Formula D-16).

Fresh D-16 Developer.—The results indicated that with a fresh developer aeration caused marked changes in its developing properties. At first the density values showed a slight decrease with increasing time of aeration, but after a period of 1½ hours, the decrease was quite rapid. After 4½ hours the solution possessed no developing properties; the speed loss followed closely the trend in density, and the alkalinity increased from a pH of 10.2 to 11.3.

The increase in developer alkalinity and decrease in activity may be explained partially by the probable reaction between hydroquinone, sodium sulfite, and oxygen, with the formation of hydro-

quinone sulfonates together with 1 mole of sodium hydroxide for each mole of hydroquinone reacting, as indicated by the following equation:



The first published accounts of the formation of hydroquinone sulfonates in a developer were by Andresen¹² and Bogisch.¹³ A large number of investigators have since examined the nature of the reaction products of development including Pinnow¹⁴ who, in 1913, isolated both hydroquinone monosulfonate and disulfonate. Subsequently, many authors have offered various explanations for the mechanism of the formation of these compounds during development including Rzymkowski,⁴ Lehmann and Tausch,¹⁵ Seyewetz and Szymson,¹⁶ and James and Weissberger.¹⁷

For the present consideration, the most important fact is that sodium hydroxide is formed as a by-product of the oxidation of hydroquinone in the presence of sulfite to hydroquinone monosulfonate. A portion of the monosulfonate probably reacts in the same way as hydroquinone to form the disulfonate with the liberation of an additional quantity of sodium hydroxide, according to the following equation:

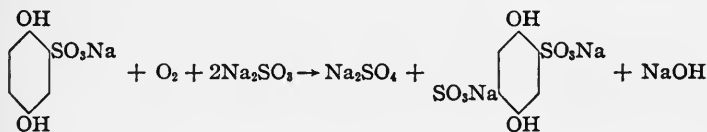

The by-products of oxidation with a hydroquinone developer are therefore sodium sulfate, hydroquinone mono- and disulfonates, and sodium hydroxide. Sodium sulfate in the concentration formed should have little or no effect on development and, according to Evans and Hanson,¹⁸ it is doubtful whether the sulfonates play any part in the development of an image. The total effect, therefore, is to raise the pH or degree of alkalinity of the developer which, in turn, accelerates the rate of development but this effect is offset by depletion in the quantity of active developing agents as a result of

oxidation. During the first stages of aeration, the alkali accumulation is sufficient to offset the depletion of developing agents but since the activity with increase in pH rapidly levels off, the photographic effect of depletion of the developing agents becomes more and more apparent with prolonged aeration.

Seasoned Developer.—The curves in Fig. 1 also show the effects produced by aeration of a developer which had been seasoned previously with 175 feet per gallon of flashed 35-mm motion picture positive film. The experimental conditions were identical with those for the fresh developer. The rate of loss of density was less than when the fresh developer was employed, no appreciable change occurring until after an initial period of $1\frac{1}{2}$ hours of aeration, after which the density values decreased but not as rapidly as with the fresh developer. The pH of the solution showed only a slight increase.

These observations are quite different from those with fresh developer when the pH increased from 10.2 to 11.3.

No precise explanation can be offered for the difference in behavior between the fresh and seasoned developers but it is reasonable to suppose that the developer reaction products served as anti-catalysts for the oxidation reaction.

When silver bromide is developed to metallic silver with a hydroquinone-carbonate developer, the following reaction probably takes place:

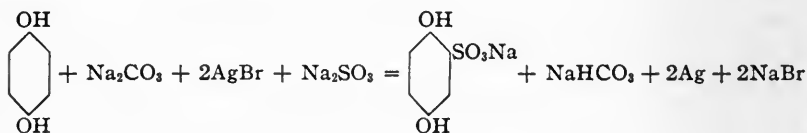

This equation would indicate that a seasoned developer should be of slightly lower alkalinity than one in which no film has been developed because of the exchange of sodium carbonate for sodium bicarbonate and the elimination of the slightly alkaline salt, sodium sulfite.

When hydroquinone is oxidized in a developer by air, the solution becomes more alkaline but, when it is oxidized by virtue of performing useful photographic work, the solution becomes less alkaline as the hydroquinone is depleted. It seems reasonable, therefore, to assume that the seasoned developer contained a small quantity of sodium bicarbonate which did not materially change the alkalinity of

the solution but was capable of reacting with its equivalent amount of sodium hydroxide formed during oxidation. The equivalent of sodium carbonate resulting from the reaction would therefore not increase the alkalinity as much as an equivalent quantity of sodium hydroxide.

During aeration, therefore, the alkalinity of a seasoned developer containing hydroquinone would show only a slight initial increase until all of the sodium bicarbonate formed during seasoning had reacted with its equivalent of sodium hydroxide. After this reaction, the sodium hydroxide formed by further aeration would cause a material increase in the alkalinity of the solution. This would explain why the alkalinity of a seasoned developer does not increase at the same rate as that of an unseasoned developer during aeration.

With the seasoned developer, the change in density observed from tests during the first 30 minutes was much less pronounced than with the unseasoned developer. It is known that small amounts of oxidized developer, when added to a fresh developer, produce antifogging and slight desensitizing effects.¹⁹ This may account for the rapid depression in density during the first 30 minutes of treatment using the fresh developer.

A Modified D-16 Developer.—Because of the recognized protective action of sodium sulfite in retarding the oxidation of organic developing agents, it was thought that a higher sulfite content might provide a considerable retarding effect during aeration. Therefore, the *D-16* developer containing double the recommended quantity of sodium sulfite was prepared and tested. From the results shown in Fig. 1, it will be seen that the increased quantity of sodium sulfite produced the following effects:

- (1) The effective emulsion speed was increased slightly.
- (2) The change in density values with aeration closely paralleled those with the unmodified exhausted developer.
- (3) The *p*H of the solution was maintained at a relatively constant value.
- (4) No increase in fog was observed.

From these tests, therefore, it is apparent that a positive type of developer containing considerably more than the normal quantity of sulfite would be somewhat more satisfactory if the developer is to be agitated by means of air.

Results Obtained with a Borax Type of Negative Developer (D-76).—Data relating to fresh and partially exhausted developers of this type

are shown in Fig. 2. The curves indicate that changes occurred immediately after subjecting the developer to aeration and that there was no great difference in behavior between fresh and partially exhausted solutions. Values for gamma and density showed a progressive increase and, after 20 hours of continuous agitation, gamma values were increased approximately 25 per cent and the density values for equal exposures increased approximately 40 per cent. This differential gain in density and gamma produced a 10 per cent increase in speed during the first hour of aeration. Fog values increased only slightly, changing from 0.10 to 0.16 for the 20-hour test.

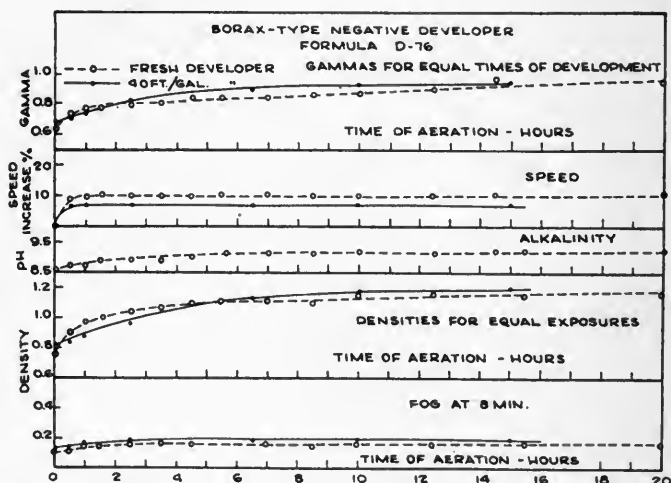

FIG. 2. Effect of aeration of a borax-type of negative developer (Formula D-76).

The alkalinity of the solutions increased uniformly from a pH value of 8.6 to 9.2. These observations were identical for fresh and seasoned developers. The increase shown in developer activity may be attributed to this increase in alkalinity which, undoubtedly, proceeded at such a rate as to more than offset the reduction in concentration of the active developing agents.

There was no appreciable difference in the shape of the H&D characteristic curves when comparisons were made at constant gamma with fresh developer and with developer which had been subjected to aeration.

Results Obtained with the Borax-Boric Acid Negative Developer (Formula D-76d).—Considering the results obtained with a borax developer, it was thought that the borax-boric acid developer devised by Carlton and Crabtree² might suffer less change on aeration because of the tendency of the solution to retain a constant pH value, and data with such a developer are given in Fig. 3.

The curves indicate that the boric acid stabilized the solution slightly but had no very pronounced effect until after several hours of aeration. The changes in gamma and density for fresh and seasoned developers were essentially similar to those obtained with the regular borax developer up to a period of 10 hours.

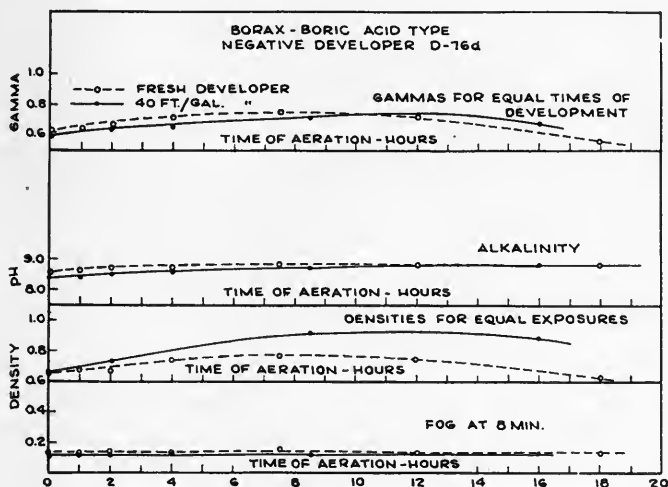

FIG. 3. Effect of aeration of a borax-boric acid negative developer (Formula D-76d).

The initial change in pH was less abrupt than with the plain borax developer and, after 10 hours, the tendency was to remain constant.

The alkalinity of the developer did not increase at the same rate as in the case of the borax developer without boric acid, due to the fact that the borax-boric acid combination has a decidedly greater buffer action than borax alone for the range of developer alkalinity under consideration. Also, the relative increase in alkalinity of either of the borax types of developer was much less than in the case of the carbonate developer which is accounted for by the fact that a com-

bination of borax and boric acid or borax alone has a relatively greater buffering effect than sodium carbonate.

Results Obtained with an Elon-Borax Developer Containing a Desensitizer (Formula D-89).—This developer was of the borax type but contained pinakryptol green as a desensitizer and no hydroquinone. From Fig. 4 it will be seen that this developer behaves somewhat differently from the other types of borax developers. The pH value of the solution remained constant at a value of 8.8 throughout the tests which would substantiate the previous deductions that it is the hydroquinone constituent of a developer which reacts to give increased alkalinity. The data show that for a fresh developer, the gamma and density values decreased continuously from the start in contrast to the negative types of borax developers already discussed

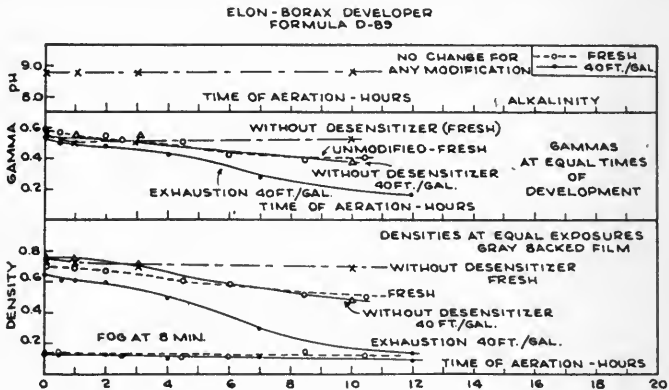

FIG. 4. Effect of aeration of an elon-borax developer containing a desensitizer (Formula D-89).

containing hydroquinone, in which case the density and gamma values increased during the initial stages of aeration.

With the seasoned developer, the general effects obtained were similar but more pronounced than with the fresh solution.

Fresh and Seasoned Elon-Borax Developers without Pinakryptol Green.—Because of the marked difference in behavior between developer D-89 and the previous borax developers, it was thought that the desensitizer might have some catalytic effect upon the rate of oxidation of elon. A solution was prepared, therefore, which contained no desensitizer. The fresh developer gave practically no change in gamma or density, while the seasoned developer produced a marked falling off in gamma and density values, the results obtained

being almost identical with those from a fresh developer containing pinakryptol green.

From these results it appeared probable that both pinakryptol green and colloidal silver which is formed during exhaustion of developers with a high sulfite content catalyzed the oxidation of elon.

Results Obtained with Developers of the MQ Series.—It is evident from the preceding experiments that hydroquinone and elon behave very differently with respect to oxidation when compounded in developing solutions. To check these observed differences further, it was thought desirable to test developers having widely differing elon

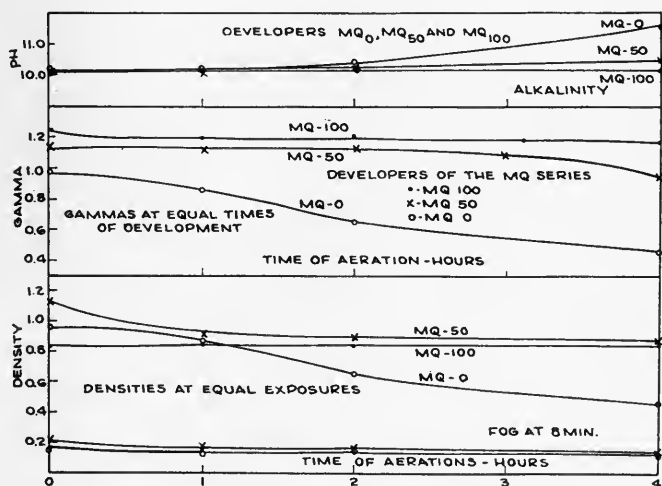

FIG. 5. Effect of aeration of developers containing various proportions of elon and hydroquinone.

to hydroquinone ratios, the other constituents remaining constant. Several members of the *MQ* series²⁰ of developers were therefore tested. The results of tests with developers *MQ-0*, *MQ-50*, and *MQ-100* are shown in Fig. 5. The developer *MQ-0* contained hydroquinone (5 grams per liter) and no elon, *MQ-50* contained equal quantities of elon and hydroquinone (2.5 grams of each per liter), and *MQ-100* contained elon (5 grams per liter) and no hydroquinone.

All the developers contained identical quantities of sodium sulfite (75 grams per liter), sodium carbonate (25 grams per liter), and potassium bromide (1.5 grams per liter).

With the *MQ-100* developer, gamma and density values did not

change as the aeration was prolonged, and the alkalinity remained constant. These results confirm previous observations with the borax developer (*D-89*), and it was concluded that elon in the presence of sulfite in alkaline solution was relatively stable toward oxidation provided no catalysts such as colloidal silver or pinakryptol green were present.

The data from the tests with *MQ-0* also confirmed the previous observations that hydroquinone was very susceptible to oxidation in the presence of alkaline sulfite solutions and reacted in a manner as to increase the alkalinity of the solution. The data with *MQ-0* were similar to those obtained with *D-16* as would be expected, since the hydroquinone-elon ratio of *D-16* is relatively high.

The results showed that the drop in density and gamma values with aeration was greatest with *MQ-0* and least with *MQ-100*. Likewise, the alkalinity increase for *MQ-50* was intermediate between that for *MQ-0* and *MQ-100*.

Tests with Miscellaneous Developers.—Tests with caustic, borax-caustic, and borax-carbonate types of developers showed that the susceptibility to oxidation of developers containing equivalent elon-hydroquinone ratios, with equal quantities of sodium sulfite, was dependent largely upon the developer alkalinity and not upon the specific alkali employed.

It is true that developers may have equal oxidation susceptibilities although their rates of oxidation may be different. This is illustrated by the results obtained with a caustic and a carbonate developer containing equal quantities of sodium sulfite and equal hydroquinone-elon ratios. The alkalinity of the solutions was adjusted by varying the quantity of alkali so as to give equal *pH* values. On aeration, both solutions commenced to oxidize at about the same time but, as the aeration was continued, the developer containing the caustic oxidized at a greater rate than that containing carbonate. By measurement it was found that the alkalinity after aeration was greatest for equal degrees of aeration in the case of the caustic developer and this may be explained by the buffering action of the sodium carbonate which tends to maintain a constant *pH* value as caustic is added as a result of oxidation of the hydroquinone.

The difference in behavior between two developers of the same formula *DK-40* compounded with (a) Kodalk and (b) an equivalent quantity of carbonate is shown in Fig. 6. Although the values for the fresh developers were equal, it is seen that the *pH* of the carbon-

ate solution (7.5 grams per liter) increased at a greater rate than that of the corresponding Kodalk developer (20 grams per liter) due, undoubtedly, to the greater buffering action of the Kodalk. The gamma values also diminished at a greater rate with the carbonate developer, due to the greater rate of oxidation at the higher pH value.

With the exhausted developers, the change in rate of photographic activity was somewhat greater than with the fresh developers, confirming the data in Figs. 1 and 2.

In the above test, the developer was aerated by rotating a small reel in a trough containing the developer at a rate of 30 revolutions

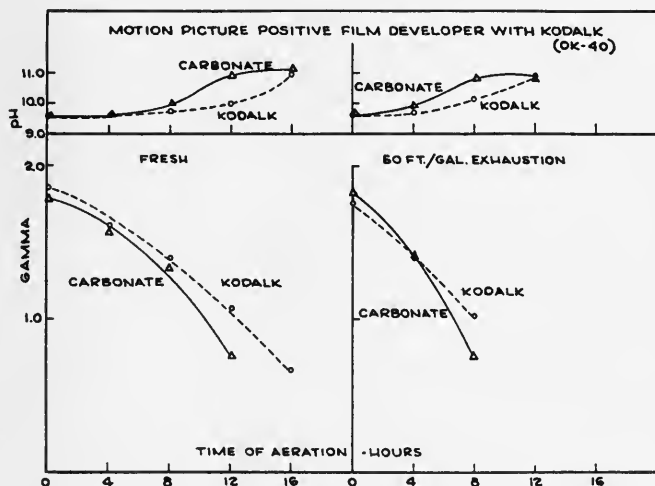

FIG. 6. Showing the difference in behavior between two developers of the same formula, *DK-40* compounded with (a) Kodalk and (b) an equivalent quantity of sodium carbonate.

per minute. The reel was wrapped with a sheet of Kodaloid so as to create a greater surface for aeration.

From the above data it may be considered that for equal pH values of the original developer, for a minimum change in photographic effect with aeration, the various alkalis are to be preferred in the order of their buffering ability, namely, (a) borax and Kodalk, (b) carbonate, and (c) caustic soda.

Effect of Sodium Sulfite Concentration on the Relative Oxidation Rates of Elon and Hydroquinone.—In order to determine the change in rate of oxidation of elon and hydroquinone in combination with

varying concentrations of sodium sulfite, various developers were compounded according to the following formula:

Developing agent	5.0 grams
Sodium sulfite (desiccated)	Varying concentrations
Sodium carbonate (desiccated)	25.0 grams
Potassium bromide	1.5 grams

The end point of the aeration test was taken as the time required to render the solution incapable of developing an image density for a given exposure on positive film, when developing for 15 minutes at

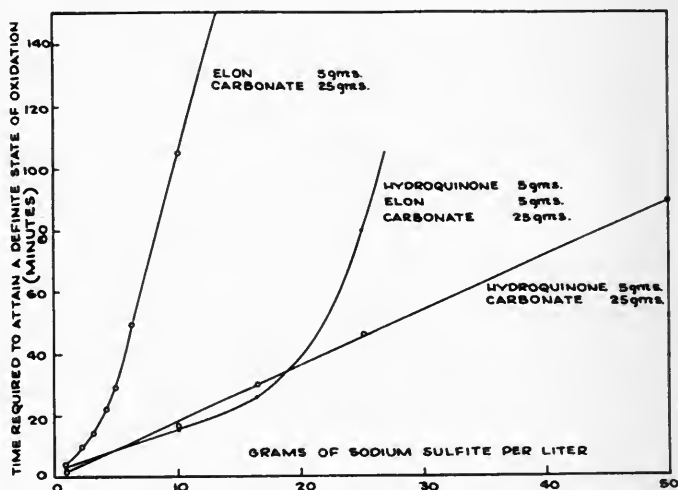

FIG. 7. Effect of sulfite concentration on the rate of oxidation of developers containing (a) elon, (b) hydroquinone, and (c) mixtures of elon and hydroquinone.

65°F. From Fig. 7 it is seen that elon was protected by sodium sulfite to a much greater degree than hydroquinone. The results with mixtures of elon and hydroquinone seem to indicate that the rate of oxidation of elon is somewhat accelerated by the oxidation products of hydroquinone, especially at low sulfite concentrations.

Effect of Temperature on Rate of Developer Oxidation.—Tests with Formula D-16 indicated that a change in temperature from 65° to 95°F had only a slight effect on the rate of oxidation.

Removal of Developer Sludge by Aeration.—Developing solutions, especially those for use with positive types of film, are usually dis-

carded when they become colored and tend to stain the gelatin.²¹ It was observed that when a badly discolored *D-16* developer was agitated with air it became lighter in color and the opalescence in the solution disappeared. On closer observation, it was seen that the froth which formed on the surface of the solution was quite dark in color and could be skimmed off, thereby leaving the solution relatively clear. Also, the clearing effect was most complete after about 15 minutes of agitation when the developer was pale straw colored but, if aeration was continued further, the hue darkened to a very dark brown. Possibly practical use could be made of this observation as a means of clarifying large quantities of developer.

Agitation with Nitrogen.—When nitrogen was used for agitating various developers, no change was observed in their photographic properties even after 10 hours of continuous aeration.

Effect of Carbon Dioxide.—Since air contains approximately 0.045 per cent (by weight) of carbon dioxide, which gas reacts with alkalis to form bicarbonates, thereby lowering their degree of alkalinity, it might be expected that carbonation of the alkalis would reduce their photographic activity apart from the oxidation phenomena.

Accordingly, aqueous solutions containing 20 grams per liter of sodium carbonate and 40 grams per liter of Kodalk, respectively, were bubbled with carbon dioxide for 16 hours in which time an appreciable effect would be obtained if air were used. The solution was then used for compounding the *D-16* and *DK-40* developers. No essential difference in the properties between these developers and solutions prepared with the treated alkalis was detected, showing that the degree of carbonation produced by the aeration was very slight.

Calculations would indicate that only 0.0015 mol of carbon dioxide would pass per hour when bubbling air at the rate of 5 cubic feet per hour. To eliminate the effect of carbon dioxide the air could, of course, be passed through a soda lime or sodium hydroxide absorber.

Effect of Sodium Arsenite and Sodium Hypophosphite.—It was thought that other protecting agents, such as sodium arsenite and sodium hypophosphite might produce better stability in a developer than sodium sulfite and, by so doing, lessen the tendency of the developer toward oxidation. When a portion of the sodium sulfite in a developer was replaced by equivalent quantities of sodium arsenite and sodium hypophosphite (from mere traces to the limit of solubility of the salts) no improved protection over that furnished by the

sodium sulfite was observed although the gamma-time characteristics were changed.

Effect of Developer Oxidation on Graininess.—Throughout the tests discussed above, the effect of developer oxidation products on the graininess of the developed images was constantly observed. When comparisons were made of images developed to equal densities and gammas at equal effective emulsion speeds, in solutions which had been aerated to different degrees, no marked differences in graininess were noted as a direct result of the aeration.

Practical Considerations.—In order to determine the practicability of employing air for agitation purposes when developing photographic materials, it is necessary to know approximately the relative extent

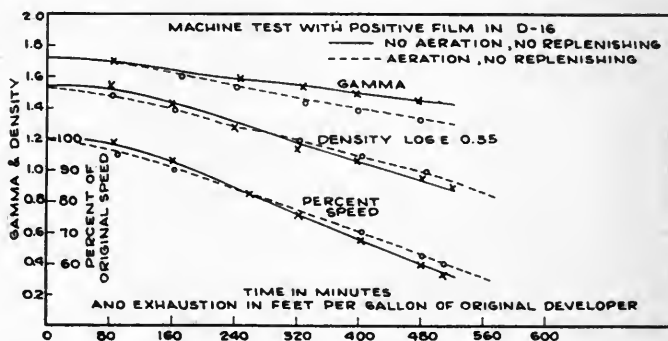

FIG. 8. Effect of exhaustion of *D-16* developer, with and without aeration, when in use in a motion picture processing machine.

of the developer exhaustion produced by (a) aeration and (b) exhaustion by virtue of performing useful work in developing the image.

It is known that the magnitude of (b) is quite considerable but this can be compensated for by suitable replenishing^{22,23} with the result that the photographic properties of a developer can be maintained over prolonged periods of use.

In order to obtain a measure of the relative magnitude of (a) and (b) in practice, exhaustion tests were made with the *D-16* developer in a continuous processing machine, using motion picture positive film. The capacity of the tank was 25 gallons, the rate of recirculation 5 liters per minute, and the film traveled at the rate of 25 feet per minute.

A test run was made over a period of 10 hours without aeration and without replenishing, and the test repeated with aeration and

without replenishing. A study of the curves in Fig. 8 shows that the rate of change in gamma and density with exhaustion was practically identical in both cases, showing that the aeration had little or no effect on the photographic properties of the solution. When the developer was merely aerated (without exhaustion or replenishing) no visible change in photographic activity occurred over a period of 10 hours.

The method of air agitation was essentially that described by Ives and Kunz¹⁰ although the severity of the agitation was much less than that obtained by bubbling air through a tube as used in the tests described above. Also, with the machine aerator, the very small air bubbles which formed in the tube aerator were eliminated, thereby reducing the rate of oxidation for a given degree of agitation.

It is apparent, therefore, that under the conditions described, the effects produced by aeration are negligible as compared with those produced by exhaustion.

In practice, with the above machine using *D-16* and motion picture positive film, replenishing is accomplished by adding developer at the rate of 225 cc per minute when developing at the rate of 25 feet per minute, the excess overflowing into the drain. The fresh developer in the tank is compounded two-third normal strength but the normal developer is used for replenishing. In this way, any slight initial increase in activity by virtue of aeration is compensated for by the lower activity of the weaker solution. Under these conditions, for a run of 200,000 feet of film, 400 gallons of replenisher were added. In the case of very dense prints, the replenisher flow was increased to 275 cc per minute while, with sound records (no picture record), this was reduced to 125 cc per minute.

The *D-76* developer has also been used successfully in combination with aerial agitation. In this case, when the capacity of the tank was 40 gallons, one-half strength *D-76*, but with the normal quantity of sulfite (100 grams per liter), was used at the start and full strength *D-76* used for replenishing. At a developing rate of 15 feet per minute, the flow of replenisher was 600 cc per minute, and the average life of the developer approximately 100 feet per gallon.

The effect of constitution on stability against change by aeration is also illustrated by the case of a low alkalinity slow-working developer for variable density sound negatives (developer *A*, Table III). This formula had performed satisfactorily in a commercial laboratory previous to the time when an attempt was made to use it under con-

ditions where agitation of the developer was obtained by the use of compressed air.

When fresh, the developing time to produce a gamma of 0.35 at 70°F with Eastman sound recording negative emulsion 1359 was 12 minutes. After a few days of intermittent use during which sound negatives were developed with agitation by compressed air, it was found that the developing rate increased to such a degree that the time for a gamma of 0.35 was reduced to 5 or 6 minutes. This increase in developer activity was more rapid in the later stages and could not be anticipated exactly.

TABLE I

Developer	Feet per Gallon (Cumulative)	Minutes of Aeration (Cumulative)	Time of Development for Gamma = 0.35
A	0	0	12.0 min.
	8 ¹ / ₂	15	11.8
	10	30	11.2
	10	30	10.0
	12	80	9.0
	12	90	7.0
	13	100	5.5
B	0	0	7.2
	8 ¹ / ₂	12	7.3
	13	60	7.3
	17	80	7.5
	24	120	7.6
	25	140	7.4

It was found that the increase in activity was accompanied by an increase in alkalinity and that the original developing rate could be restored by the addition of 0.25 gram of citric acid per liter. None of the change could be ascribed to the replenishment because this consisted merely of adding developer of the original formula at the rate of one gallon for 200 feet of film processed. The increase in activity in the course of use was largely a result of oxidation of the hydroquinone by air with the production of sodium hydroxide. Under the new condition of use the rate of aeration must have been increased relative to the rate at which reaction products of development were produced. The buffering effect of citric acid in such a formula would not be very great at the pH of 8.5 for the freshly mixed developer.

After some small scale tests, developer B (Table III) was compounded in order to insure more stable operation under the same conditions of use.

Results obtained with developer formulas *A* and *B* under similar conditions of use in a 120-gallon quantity are shown in Table I. With each, sound negatives were developed from time to time throughout a period of several days. The emulsion for testing was Eastman sound recording negative 1359. Development times are given for a gamma of 0.35.

Thus the necessary stability shown by a practically constant time of development was obtained with somewhat increased chemical concentrations. The chemical consumption would depend upon the extent of use before rejection or upon replenishing rate as determined over a longer period of use than that shown.

In contrast to the case just described unintentional aeration of a comparatively stable developer may produce very troublesome changes in developer performance. The following data show the change in *pH* of a *D-76* type of developer in the course of a few hours use in a system in which the air was being entrained in the return pipe of the recirculation line as a result of allowing the pipe to run only partly filled.

TABLE II

Period of Use (Cumulative)	Feet of Film Developed (Cumulative)	<i>pH</i>
0	0	8.4
45 min.	200	8.5
1 ³ / ₄ hours	2400	8.7
2 ³ / ₄ hours	4400	8.8
3 ³ / ₄ hours	5200	8.9
7 ³ / ₄ hours	5900	9.0
10 ³ / ₄ hours	6700	9.1

This change in *pH* was found to accompany an increase in the rate of development of about 60 per cent.

There are various ways in which this aeration can occur as, for example, at a leaky pump packing. The air passing through a pump is probably broken up into small bubbles, providing a large surface of contact with the developer. A similar rate of change in *pH* and activity was obtained by delivering air in very fine bubbles into a 500-cc quantity of the same developer. Under these conditions the rate of change was about the same either at atmospheric pressure or at approximately two atmospheres. An almost identical change in the photographic characteristics was brought about by the addition to the fresh developer of sufficient sodium hydroxide to obtain the same in-

crease in pH as that caused by the aeration. This, however, would not be true for a case where the aeration had been prolonged to the point where developing agents were largely consumed by oxidation.

SUMMARY

(1) The effect of agitation of developers with air has been studied under conditions somewhat more severe than usually occur with motion picture film processing machines.

(2) Fresh elon-hydroquinone developers of relatively high alkalinity ($pH = 10.0-10.5$) oxidized more rapidly than those of low alkalinity (borax type, $pH = 8.4-8.8$). Developers of the first type showed a very rapid decrease in activity after $1\frac{1}{2}$ hours of aeration while those of the second type generally showed increased activity with no falling off after prolonged treatment (15 hours).

(3) In general, partially exhausted elon-hydroquinone developers showed less susceptibility to aeration than fresh developers.

(4) Developers with high sodium sulfite content (50 to 100 grams per liter) were found to be generally more stable than developers containing less than 50 grams per liter.

(5) The susceptibility of a developer to oxidation is dependent upon the initial alkalinity of the solution, other constituents remaining constant, and not upon the particular alkali employed. For a given alkali, the rate of oxidation of a developer increased with increasing alkalinity. In the case of hydroquinone this rate has been shown by other investigators to vary as the square of the hydroxyl ion concentration.²⁴

(6) On aeration, the alkalinity of all developers containing hydroquinone increased, while those containing only elon showed no change.

(7) The effect of temperature on the oxidation reactions taking place in elon-hydroquinone developers was negligible between temperatures of 65° and $75^{\circ}F$.

(8) Discolored and sludged developers may be partially clarified by aeration.

(9) Agitation with nitrogen over a long period produced no change in the activity of a developer.

(10) No apparent change in graininess characteristics of the developers tested was produced by aeration.

(11) Experience has shown that it is entirely practical to agitate motion picture machine developers with air when suitably replenished. The method¹⁰ is economical and, with suitably constructed grids for

distributing the air, excellent uniformity of development can be obtained.

The authors are greatly indebted to C. E. Ives and C. J. Kunz for assistance in the experimental work.

REFERENCES

- ¹ CRABTREE, J. I.: "Development of Motion Picture Film by the Reel-and-Tank Systems," *Trans. Soc. Mot. Pict. Eng.* (1923), No. 16, p. 163. (Revised 1927.)
- ² CARLTON, H. C., AND CRABTREE, J. I.: "Some Properties of Fine-Grain Developers for Motion Picture Film," *Trans. Soc. Mot. Pict. Eng.* (1929), No. 38, p. 406.
- ³ LÜPPO-CRAMER: "Aging of Metol-Hydroquinone Solutions," *Phot. Ind.*, **29** (1930), p. 1180; *ibid.*, **29** (1931), p. 548.
- ⁴ RZYMKOWSKI, J.: "The Increase of Development Velocity with Age of Weak Alkaline Developers," *Phot. Ind.*, **29** (1931), p. 825.
- ⁵ MEES, C. E. K., AND PIPER, C. W.: "The Fogging Powers of Developers," *Phot. J.*, **35** (1911), p. 226; *ibid.*, **36** (1912), p. 221.
- ⁶ CRABTREE, J. I.: "Chemical Fog," *Amer. Ann. Phot.*, **33** (1919), p. 20; *Brit. J. Phot.*, **66** (1919), p. 97.
- ⁷ DUNDON, M. L., AND CRABTREE, J. I.: "The Fogging Properties of Developers," *Trans. Soc. Mot. Pict. Eng.* (1928), No. 36, p. 1096.
- ⁸ FUCHS, E.: "Aerial Oxidation of Developers and the Formation of Fog," *Phot. Ind.*, **27** (1924), p. 56.
- ⁹ CRABTREE, J.: "Directional Effects in Continuous Film Processing," *J. Soc. Mot. Pict. Eng.*, **XVII** (Feb., 1932), p. 207; CRABTREE, J., AND WADDELL, J. H.: "Directional Effects in Sound-Film Processing—II," *J. Soc. Mot. Pict. Eng.*, **XXI** (Nov., 1933), p. 351.
- ¹⁰ IVES, C. E., AND KUNZ, C. J.: "Solution Agitation by Means of Compressed Air," *J. Soc. Mot. Pict. Eng.*, **XXXIV** (April, 1940), p. 364.
- ¹¹ JONES, L. A.: "A Motion Picture Laboratory Sensitometer," *J. Soc. Mot. Pict. Eng.*, **XVII** (Oct., 1931), p. 536.
- ¹² ANDRESEN, M.: "The Chemistry of Organic Developers," *Phot. Korr.*, **37** (1900), p. 185.
- ¹³ BOGISCH, A.: "Reduction and Developing Power," *Phot. Korr.*, **37** (1900), p. 93.
- ¹⁴ PINNOW, J.: "The Action of Oxygen on Hydroquinone and Sodium Sulphite," *Z. Wiss. Phot.*, **11** (1913), p. 289; "The Deterioration with Keeping of Sulphite-Hydroquinone Solutions," *Z. wiss. Phot.*, **22** (Aug., 1922), p. 72; "Sulphite in Developers," *Phot. Rund.*, **60** (1923), p. 27.
- ¹⁵ LEHMANN, E., AND TAUSCH, E.: *Phot. Korr.*, **71** (1935), p. 17; TAUSCH, E.: "The Chemistry of Photographic Developers," *Dissertation*, Berlin, 1934.
- ¹⁶ SEYEWETZ, A., AND SZYMSON, S.: "On the Oxidation of Organic Developing Agents," *Bull. de la Soc. Fran. de Phot.*, **21** (1934), p. 71.
- ¹⁷ JAMES, T. H., AND WEISSBERGER, A.: "Oxidation Processes, XI—The Autoxidation of Dihydroquinone," *J. Amer. Chem. Soc.*, **60** (1938), p. 98.

¹⁸ EVANS, R. M., AND HANSON, W. T., JR.: "Reduction Potential and Photographic Developers," "The Effect of Sulfite in Developer Solutions," *J. Phys. Chem.*, **41** (April, 1937), p. 509.

¹⁹ DUNDON, M. L., AND CRABTREE, J. I.: "Investigations on Photographic Developers—III," "The Effect of Desensitizers in Development," *Trans. Soc. Mot. Pict. Eng.* (1926), No. 26, p. 111.

²⁰ MEES, C. E. K.: "A Simplified Method of Writing Developing Formulas," *Brit. J. Phot.*, **64** (1917), p. 535.

²¹ CRABTREE, J. I., AND DUNDON, M. L.: "The Staining Properties of Motion Picture Developers," *Trans. Soc. Mot. Pict. Eng.* (1926), No. 25, p. 108.

²² CRABTREE, J. I., AND IVES, C. E.: "A Replenishing Solution for a Motion Picture Positive Film Developer," *J. Soc. Mot. Pict. Eng.*, **XV** (Sept., 1926), p. 627.

²³ JAMES, T. H., SNELL, J. M., AND WEISSBERGER, A.: "Oxidation Processes, XII—The Autoxidation of Hydroquinone and of the Mono-, and Di-, and Trimethylhydroquinones," *J. Amer. Chem. Soc.*, **60** (1938), p. 2084.

²⁴ EVANS, R. M.: "Maintenance of a Developer by Continuous Replenishment," *J. Soc. Mot. Pict. Eng.*, **XXXI** (Sept., 1938), p. 273.

THE EPOCH OF PROGRESS IN FILM FIRE PREVENTION*

ALBERT F. SULZER**

Summary.—*Motion picture film and the characteristics of its support are discussed from the point of view of safety. A survey is given of the work carried out by the Eastman Kodak Company in conjunction with the motion picture industry, boards of underwriters, the National Fire Protection Association, and government bodies, on the control of the fire hazard in the production, distribution, and use of cellulose nitrate film for motion pictures. The characteristics and use of cellulose acetate film are considered in relation to the problem.*

It is a privilege and an honor to be asked to present the story of the accomplishments in fire prevention in the motion picture industry. The Eastman Kodak Co., having developed and introduced the flexible, transparent film that made the motion picture industry possible, and because of its long experience in the manufacture of this film, is undoubtedly in the best position to outline this problem in its entirety.

To understand the magnitude of the problem and the difficulties involved in fire prevention in the motion picture industry, we must go back to the beginning of the use of film in photography. In 1880, when Mr. Eastman began the manufacture of dry plates, he realized that photography could not be made popular with the average individual until something less bulky and less breakable than glass-plate negatives could be produced.

In 1885, he first introduced stripping film, as it was called, which consisted of paper, coated first with a layer of soluble gelatin, then with a thin layer of collodion (nitrocellulose), and finally with a coating of sensitized emulsion. The film was exposed by the photographer, then sent back to the Company, where it was developed and laid emulsion-side down on a glass plate. The soluble gelatin layer

* An address delivered before the Greater New York Safety Council, Hotel Pennsylvania, New York, N. Y., March 27, 1939.

** Eastman Kodak Co., Rochester, N. Y.

was then softened and the paper was stripped off, thus leaving a transparent negative on the glass plate for printing.

Although this next development, stripping film, broadened the field of amateur photography considerably, Mr. Eastman realized that it was not the final answer. He therefore employed a chemist in 1886 to devote all of his time to the development of a suitable flexible, non-breakable, transparent material which could replace the paper of the stripping film and also serve as a permanent support for the sensitized emulsion.

Collodion, which is a solution of cellulose nitrate in ether and alcohol, had been used in wet-plate photography, the method that replaced the early Daguerreotype process. It was the best known and practically the only known transparent material that would form itself into a continuous film when the solvents were evaporated. The film formed from collodion was found wanting, however, in many respects as a support for photographic emulsions.

Mr. Eastman was familiar with collodion from his experiments with wet-plate photography before he developed the Eastman gelatin dry plate with which he began his business career in photography. His later experiments in search of a transparent, flexible emulsion-support demonstrated the unsuitability of collodion for this purpose. Despite the defects of collodion, however, it was natural that the experimenter should concentrate on nitrocellulose, its main ingredient, in his search for a transparent, flexible support. After 3 years of experiments, a formula of nitrocellulose and camphor in solution, suitable for negative support, was perfected, and commercial production of nitrocellulose film base was started in 1889.

PROPERTIES OF NITRO FILM

Nitrocellulose is inflammable. Inflammability increases with the degree of nitration of the cellulose. Experiments demonstrated that, to produce a nitrocellulose suitable for film support, a low degree of nitration must be maintained so that the resulting nitrocellulose would be less inflammable, less subject to decomposition, and of the correct solubility.

Nitrocellulose as used for photographic purposes is not explosive, but is inflammable; and intelligent care must be exercised in its production, storage, and use. Nitrocellulose film base will not only burn rapidly when ignited, but also, if subjected to sufficient heat, will decompose without flame. This film base contains enough combined

oxygen to maintain decomposition when once started, even in a limited air supply. Decomposition liberates comparatively large quantities of carbon dioxide, carbon monoxide, and oxides of nitrogen, which under certain conditions are dangerous to life. Some of these liberated gases are also inflammable, and under some conditions are explosive.

Since decomposition, when once started, will maintain itself and generate enough heat to produce combustion, the obvious control, lies, not in methods intended to smother the fire by excluding the air supply, but by the application of large quantities of water sufficient to cool the burning film below the decomposing temperature of about 300 degrees F. Experiments demonstrated that such an application of water will also cool the liberated gases sufficiently to make explosion, and even ignition, unlikely. This theory was followed in fire-protection measures developed by the Eastman Kodak Co., to which we will refer later.

Nitrocellulose film was first used only in roll film for amateur photography. The development of equipment for the taking and subsequent projection of pictures which would seem to move had been waiting, however, for a flexible film. Therefore, almost immediately after Mr. Eastman announced the availability of flexible negative material, Thomas A. Edison, realizing that this was the answer to one of his most perplexing problems, sent one of his men to Rochester to bring back samples with which he might carry on his experiments on motion picture cameras. Mr. Edison's first confirming order, covering a prior delivery of motion picture film, bears the date of Sept. 2, 1889.

FIRST COMMERCIAL SHOWS

Motion pictures first appeared commercially in peep shows in 1894. Then, on May 20, 1895, the first motion pictures were projected on a screen commercially, at 153 Broadway, New York City. This was a four-minute picture of a prize fight. Progress was at first slow, but, by the late nineties and early nineteen hundreds, motion picture shows—often referred to as nickelodeons—were becoming more common. Production was low, however, and the quantities of film on hand were necessarily small.

These early films were short. A show usually consisted of one, or at most two, subjects. The show lasted twenty to thirty minutes. Twenty to thirty shows were put on daily; but the seating capacity

of the theaters, many of which were remodeled stores, usually did not exceed one hundred.

Because of the constantly increasing use of motion picture film, which is not backed or interleaved with paper, and because of some serious fires that occurred in theaters and exchanges, the Eastman Kodak Co. became vitally interested in the problem of fire prevention.

In 1906, Kodak began experimenting with cellulose acetate, which has the same transparent properties as cellulose nitrate and in addition is no more inflammable than paper, wood, or many other forms of ordinary cellulose. In addition to its lower inflammability, cellulose acetate will not decompose readily when heated; and, except for carbon monoxide, it does not give off toxic gases when it burns. No more carbon monoxide is released from cellulose acetate when it is burned in a limited air supply than is given off by equal quantities of ordinary cellulose, such as paper or wood.

ACETATE FILM UNSUITABLE

In 1909, Eastman had developed cellulose acetate to a point where the Company felt it could be substituted for nitrocellulose in motion picture film. To give effect to this development, Mr. Eastman arranged a meeting with the leaders of the motion picture producing companies. Because the advantages of the new film were obvious to all, little argument was needed to reach an agreement whereby only cellulose-acetate film was to be supplied by the Company thereafter.

Experience demonstrated, however, that acetate film was not as strong mechanically as nitrocellulose film and that it became brittle with use. Difficulty in the projection of the acetate film was experienced partly because of the inferior quality of the film but also because of the inferior projection equipment of that day and the rough handling to which the film was subjected.

Although some improvements ensued in film, in projection equipment, and in handling, the motion picture producers asked in 1911 to be released from their agreement to use only cellulose-acetate film. Thus, in less than two years, the Eastman first attempt to substitute slow-burning cellulose-acetate film for nitrocellulose film came to an end. This attempt failed, not because of lack of coöperation on the part of the motion picture producers, but because of the failure of the cellulose-acetate film to perform satisfactorily under the conditions to which it was subjected.

The period from 1911 to 1922 was one of research, education, and

coöperation: research in methods of making the production, distribution, and exhibition of motion pictures safe to the public and the workers involved; education of everyone involved in these activities, including not only the industries themselves but also the fire departments, transportation companies, and public officials, local, state, and national; and, finally, complete coöperation which resulted from these research and educational undertakings.

With the return in 1911 to the production and use of nitrocellulose film for the motion picture industry, Eastman coöperated wholeheartedly with the motion picture producers, the national and local boards of underwriters, the National Fire Protection Association, and the various governmental bureaus and administrators, in the development of devices and methods to control the fire hazard in the production, distribution, and use, of cellulose-nitrate film for motion pictures.

Although in a period of five years—1912 to 1917—the reports of the N. Y. City Fire Department show that film was the cause of only $12/100$ of one per cent of the number of fires in N. Y. City, and $28/100$ of one per cent of the losses by fire, the potential hazard in the use of the film was realized. As a first official step, ordinances were passed, at the instigation of the boards of fire underwriters, to make the projection of motion pictures in the theaters safe for the public.

U. S. GOVERNMENT SURVEY

Following the Ferguson Building fire in Pittsburgh on Sept. 7, 1909, the U. S. Geological Survey made a thorough investigation to determine the probable causes. From this investigation, and from laboratory tests, it was concluded that the explosion accompanying that fire was caused by the ignition of gases generated under pressure in a closed, unvented vault in which a quantity of nitrocellulose film decomposed after being ignited by the breaking of an electric light bulb. This explosion did not occur in the vault, but the gases which escaped into an adjoining room formed an explosive mixture with the air of the room and were ignited by a fire burning outside the vault.

The laboratory tests made at that time confirmed these conclusions and proved that nitrocellulose film is not explosive; and proved, furthermore, that the gases generated by film decomposition at atmospheric pressure are of a low inflammability, but that, if the film decomposes under pressure, the gases generated, when properly diluted by air, are explosive.

The results of these tests were given wide circulation, and ordinances were enacted, in practically all of the major cities, requiring the projection rooms in motion picture theaters to be amply vented to the open air and to be completely isolated from the theater auditorium. These precautions and other restrictions—plus education as to the volume of film and its hazards—are largely responsible for the practical absence of fires in motion picture theaters.

Another source of hazard lay in the wornout, obsolete, or discarded film. With the greatly increased use of motion pictures and with longer subjects, this obsolete film piled up rapidly in the exchanges. In 1918, Eastman inaugurated the plan of purchasing this discarded film, for recovery of its constituent materials for non-photographic purposes. The film was, and still is, collected and shipped to Kodak Park, Rochester, and to other responsible converters, thus removing one of the greatest sources of fire hazards in the exchanges. In addition, safe methods were devised for handling this scrap, and these were made available to others who wished to carry on the recovery of scrap film as a business, with safety to property and life.

Despite the fact that the number of fires and losses attributable to nitrocellulose film continued small in comparison with other causes such as gasoline, matches, smoking, and carelessness, agitation against the use of nitrocellulose film continued.

In 1915, the committee on explosives and combustibles of the National Fire Protection Association, in cooperation with the N. Y. City Fire Department and the Universal Film Co., conducted a test at Fort Lee, N. J., by burning a large quantity of discarded motion picture film in a vault which, though properly vented, was not equipped with automatic sprinklers.

This test was very spectacular. No explosion accompanied the fire, but the heat was so intense that a giant torchlike blast of flame shot horizontally out of the vault vent for many feet. Numerous tests which had been made by Eastman in its work of protecting its employees and its own property from the hazards of film fires, had demonstrated, previous to the Fort Lee tests, that properly arranged sprinklers will control film fires.

Immediately following the Fort Lee tests, the Eastman Company, believing that the severity of fires under conditions of the Fort Lee tests could be greatly lessened and could be controlled, ran a series of tests in 1915 and 1916 to determine the inflammability of film, the protective effectiveness of water in varying quantities from properly

arranged sprinklers, and the protective effectiveness of various methods of packaging and storing motion picture film.

In the Eastman tests, conditions as to volume and arrangement of film were equal to or more severe than the conditions in the Fort Lee tests. These tests, together with earlier tests run by the Company, proved conclusively that, with properly constructed and vented vaults, film fires can be readily extinguished by sprinklers, and, in addition, decomposition can be prevented from communicating to other films in the same storage racks. These tests also proved that, in properly vented vaults, sprinklers will cool the liberated gases so that explosion, or even ignition, of liberated gases is improbable.

These tests were witnessed by officials of the N. Y. City Fire Department and also by representatives of the underwriters and insurance companies. The results did much to convince these people that film fires in vaults can be controlled by automatic sprinklers, with proper venting and with proper limitation of quantity stored; and also that the safe storage of large quantities of film is possible if proper precautions are taken.

While the Eastman Company was experimenting with methods of fire prevention for nitrocellulose film, the inspection department of the Associated Factory Mutual Fire Insurance Companies was carrying on similar experiments with pyroxylin plastics, commonly known as Celluloid. A comprehensive report of these tests was published in 1916. Pyroxylin contains nitrocellulose similar to that used in motion picture film. The findings in this report were in agreement with the findings of the U. S. Geological Survey in the investigation of the Ferguson Building fire in Pittsburgh. This latter report, however, included definite specifications for limitation of storage-vault capacity and for adequate venting and sprinkling.

In 1919, the N.F.P.A.'s committee on explosives recommended a similar code, or specification, for the storage of cellulose-nitrate film. These reports, and those of the Eastman experiments in the same years, dealt with the fundamentals, and have formed the basis, first, for fire underwriters' rulings, and, later, for laws and ordinances governing the transportation, storage, and handling of all nitrocellulose motion picture film.

From 1916 to 1919, Eastman prepared a series of booklets entitled, *Suggestions on Fire Prevention*. The first booklet dealt with automatic sprinklers; the second, with housekeeping; the third with motion picture film, its characteristics, and hazards; and the fourth

with the results of the tests on motion picture film fires in vaults. Arrangements were made with the motion picture producers to make these booklets available to all persons in the industry responsible for the production, processing, handling, and storage, of film. These booklets, except one describing the tests, were written in plain, non-technical language, so that their message could be readily understood by the non-technical employees in the industry.

FIELD EDUCATIONAL WORK

In addition to this prepared material, the Eastman offer to send out experts to all exchanges to inspect the exchanges and instruct the managers in proper fire-prevention methods was accepted by the motion picture producers. Six men were specially trained for this work and covered the four hundred exchanges in the U. S. and Canada. Formal and very complete reports of these inspections were forwarded to the exchange managers and also to the officials at the headquarters of the companies owning the exchanges.

Following the first inspections, the Eastman Company, collaborating with the Fire Underwriters and with various government agencies, drew up plans and specifications for film exchange buildings. These plans and specifications were so prepared that they could be readily adapted to local conditions, and they were made available to motion picture producers and to others who wished to build new film exchanges or to rehabilitate existing ones. Eastman also provided a consulting service for the producers in this work.

Follow-up inspections showed that conditions had materially improved, indicating that, if those vitally interested in the problem of fire prevention are informed, effective coöperation is possible. This work of inspection and consultation was carried on by Eastman until 1922, when it was turned over to the newly organized M.P.P.D.A. The best evidence that that organization has successfully carried on the work is to be found in the comparative absence of exchange and theater fires, even with the constantly increasing volume of film produced and handled.

Beginning in 1922 and continuing up to the present time, we have had a long period of consolidation of the progress made and of assimilation of the information developed by experience and experimentation. Although—as has been pointed out—the number of fires and the amount of fire loss caused by film, or in which film be-

came involved, had been small, compared with numbers and losses from other causes, there had been a number of spectacular fires.

PROPOSED NITRO BAN

In spite of the fact that investigations following these fires showed that, in general, known preventive measures had not been properly applied, there were demands periodically to outlaw the use of nitrocellulose film. In 1919, at Ottawa, the resolutions committee of N.F.P.A. offered the following resolution: "The universal adoption and exclusive use of slow-burning motion picture film with national, provincial, state and local legislation to prevent the continued manufacture and distribution of material having the hazardous properties of gun cotton stock now commonly employed."

This was Item 10 in a series of eleven items in the resolutions proposed by the committee. Item 10 caused more discussion than all the other ten items in the proposed resolutions, combined. There was a decided difference of opinion; but, because of the extensive laboratory tests and practical full-scale tests that had been carried on to determine the nature and hazards of cellulose-nitrate film, and because of the demonstrated effectiveness of methods of control, the great preponderance of opinion favored regulation of use rather than imposing the impractical alternative in Item 10 on the great and growing industry of production and exhibition of motion pictures. The resolutions, when adopted, formed the platform for the year, and were used as the basis of insurance-rate rulings and requirements and for legislation to make them effective.

ACETATE FILM UNSUITABLE

Experience with cellulose-acetate film for commercial motion pictures in the years 1909 to 1911 had demonstrated that it was entirely unsatisfactory. Progress had been made in improving its wearing qualities, but in 1919 it still was far behind nitrocellulose film in this respect.

Legislation in practically all communities had been enacted to make the exhibition of nitrocellulose film safe for the public. The conditions in the exchanges had been improved, and the Eastman Company, at the time of the Ottawa meeting, was preparing to send out experts to help the motion picture producers to improve still further the conditions in the exchanges. Tests by government agencies and by others had proved that nitrocellulose film is not ex-

plosive—as we have pointed out—and records proved that the number of fires attributable to film was negligible compared with the number attributable to any other cause.

All of these facts and others were brought out in the discussion of Item 10 of the 1919 resolutions. As a result, the resolutions as finally adopted included a revised Item 10, reading as follows: "That the use of motion picture projection machines without a standard booth ventilated to the outside of the building, in churches, schools, clubs, hospitals and homes, be prohibited unless the film used is of the slow-burning type and that state and municipal laws and ordinances be adopted regulating motion picture exchanges, tending toward the ultimate end that motion picture films of the nitrocellulose type be replaced when practicable by a slow-burning film."

The great majority of the membership of the N.F.P.A. is made up of men representing the insurance companies, of fire underwriters, and of public officials. Only a small number of members represent either the film manufacturers or the motion picture producers. When these facts are taken into consideration, the action taken on this resolution is convincing evidence of the enlightened coöperation which made the control of fire hazard in the motion picture industry possible.

The M.P.P.D.A. had taken up, shortly after it was organized in 1922, the educational and inspection work started by Eastman in 1919, and had accomplished much in the control of use, transportation, and handling, of nitrocellulose film. From time to time, however, nitrocellulose film appeared in stores and found its way into use in improperly protected projectors. In addition, scrap nitrocellulose film was in some cases transported and handled in an improper manner.

Because of these difficulties, the N.F.P.A. public-information committee, in its report in 1923, proposed recommending to the states and provinces of the United States and Canada the enactment of a model law to control the use of nitrocellulose film. This model law provided for "the control of use of nitrocellulose motion picture film and for the licensing of manufacture, use, handling, disposition, and transportation of such film."

As in the case of the 1919 resolution, this proposed law was thoroughly and earnestly discussed. No one opposed the idea of regulation or the necessity for such regulation. A minority, however, felt that the Association should not pass such a recommendation, but

should again go on record as supporting the early substitution of slow-burning film for nitrocellulose film for all purposes.

After much debate which again brought out the progress which had been made in the control of the fire hazard in the use of nitrocellulose film, the Association adopted unanimously the committee's proposed model law. This action and the action at Ottawa in 1919 are good examples of an association membership made up principally of persons not selfishly interested in a commercial enterprise taking constructive action to safeguard the interests and well-being of the public, instead of destructive action, which could not have been as fruitful in safeguarding the interests of all concerned.

As further evidence of the M.P.P.D.A.'s interest in the matter of public welfare, attention should be directed to its reports to the 1924 and 1925 annual meetings of the N.F.P.A. These are progress reports giving accounts of coöperation and outstanding accomplishment. (Coöperation, I must point out again, is the thread that has run through the whole fabric.)

More thorough and more frequent inspections, coöperation with and from local fire departments, introduction of fire drills, circularization of exchanges with educational matter, sponsoring of bills for the control of use of nitrocellulose motion picture film, are some of the activities of the M.P.P.D.A. Film boards of trade were organized in many cities. These boards included in their membership both the members of the M.P.P.D.A. and of the independent companies. Thus the organized efforts in accident and fire prevention were extended to the entire industry.

This educational and inspection work has been carried on by the M.P.P.D.A. to the present day. The annual cost, although heavy, is justified by the results. The increase in volume of film handled has been enormous, and the number of persons involved in the many necessary operations has increased accordingly. The price of safety in any industry is eternal vigilance.

Naturally, this story told by the Eastman Kodak Co., in spite of effort to view it dispassionately, must needs be colored to some extent by the Company's interest in the matter. If its actions were said to be motivated by self-interest, however, it was at the very least an enlightened self-interest, and the same is no less true of the motion picture industry as a whole. As I said in my opening remarks, it is a story of accomplishment of great value to the public, made possible by one dominant factor—coöperation.

NEW MOTION PICTURE APPARATUS

During the Conventions of the Society, symposiums on new motion picture apparatus are held, in which various manufacturers of equipment describe and demonstrate their new products and developments. Some of this equipment is described in the following pages; the remainder will be published in subsequent issues of the Journal.

SAFEGUARDING THEATER SOUND EQUIPMENT WITH MODERN TEST INSTRUMENTS*

A. GOODMAN, R. J. KOWALSKI, W. F. HARDMAN, AND W. S. STANKO**

Since the early days of sound motion pictures, the service branch of the industry has kept pace with the various developments and improvements in the art. In 1928 the field engineer was equipped with a minimum of tools and test equipment. In contrast, today he carries a complete set of modern service instruments and tools which comprise the following:

(1) Complete technical data on Photophone and equipment of other manufacturers

(2) Special Weston analyzer

(3) Special Weston power level meter

(4) Socket selector kit

(5) Tool kit

(6) Special wrenches

(7) Speed counter

(8) Loud speaker adjustment tool

(9) Standard frequency test-film

(10) 7000 and 9000-cycle focusing films

(11) Lateral adjustment film (buzz track)

(12) Push-pull test-film

(13) Academy dialog and music film

(14) Universal a-c bridge for measurement of resistance, capacity, and inductance

(15) Cathode-ray oscillograph

(16) Beat-frequency oscillator

(17) Emergency amplifier and speaker system

Technical Data.—Each field engineer maintains a complete file of Photophone equipment bulletins and, in addition, is furnished with up-to-date technical

* Presented at the June 21, 1939, Meeting of the Atlantic Coast Section.

** RCA Manufacturing Co., Camden, N. J.

information on all new improvements in the art. Complete data on equipment other than Photophone are furnished to him and these data are kept up-to-date, so that RCA field engineers can service any type of theater sound reproducing systems.

Analyzer.—The Weston analyzer, together with the power level meter and socket selector kit, were made to RCA specifications for application to theater sound work. The analyzer incorporates a 20,000-ohm-per-volt meter with scales up to 1000 volts. In addition, provision is made for checking any range of current or resistance normally encountered in routine service work. The socket selector kit is designed for checking tubes in the amplifying equipment making it possible to test under dynamic conditions.

Power Level Meter.—Since a 15-ohm output impedance has been standard on Photophone equipment for a number of years, the power level meter is calibrated for this impedance and a 12.5-milliwatt reference level. Charts are provided from which correction factors can be obtained when the meter is used on circuits of different impedance or when other reference levels are necessary. This meter is used in conjunction with the standard frequency film or beat-frequency oscillator in obtaining overall system frequency response or complete transmission runs.

Tool Kit.—The tool kit contains all the necessary tools for proper installation and service operation on the complete equipment. In addition there are special sound-head wrenches and motor alignment tools. A Starrett speed counter is included for accurately measuring film speed.

Frequency Test-Film.—The present frequency test-film has been designed with the view toward making it more useful in field work. Accordingly, identical tracks are recorded on each edge of the film, thereby eliminating the need for re-winding after each test. This greatly speeds up the work of taking response curves.

Thirty-three frequencies are included, from 30 to 10,000 cycles, with the 1000-cycle reference at the beginning and end of each track. Additional frequency recordings are included between 2000 cycles and 3000 cycles to provide a more comprehensive overall response test. The response is held within ± 0.5 db throughout the frequency range.

Buzz-Track and 9000-Cycle Film.—For adjustment of film position with respect to the sound-head light-beam, each engineer carries a small section of so-called buzz-track. The recording consists of two narrow chopper tracks so spaced that neither will affect the light-beam if the guide rollers are in proper lateral adjustment. This test-film has been in use since its development, in 1930, by W. W. Jones, now Manager of New York District Service Operations, to whom the patent was originally issued.

On the other edge of the film there is a 9000-cycle recording employed for focusing the light-beam on the film. The film is used in conjunction with an output meter to determine when the beam is correctly focused on the sound-track.

Push-Pull Test-Film.—With the advent of push-pull sound-heads, it was necessary to provide a test-film for adjustment of the optical systems. This film consists of a 6-mil "septum" track on one edge for adjusting the division of the light-beam and a 300-cycle track on the other edge, for correctly balancing the

output of the dual photocell. The 300-cycle portion is also used to balance the output from each sound-head.

Theater Sound Test-Reel.—RCA field engineers are now equipped with the latest theater sound test-reel produced by the Research Council of the Academy of Motion Picture Arts and Sciences. The following description of the film is taken from the Academy *Technical Bulletin*:

“The reel contains sound and picture, the sound consisting of dialog and music recordings so chosen that the assembled reel contains a representative example of sound as currently recorded by each sound department. One of these recordings is a ‘Hi-Range’ print which serves as a check on the amplifier capacity in relation to the volume of the auditorium under consideration.



FIG. 1. Universal Inductance, Capacity, and Resistance Bridge.

“The reel also contains approximately 100 feet of piano and 12 feet of 3000-cycle recordings included for the purpose of furnishing a more critical flutter test.

“After setting the theater sound reproducing equipment to the Standard Electrical Characteristic, the Theater Sound Test-Reel furnishes a tool by which an optimum setting for presence and intelligibility, combined with a natural balance between high and low frequencies, may be obtained for all current product and for the individual theater.

“The use of this reel demonstrates the inadvisability of having too much low-frequency electrical response which brings out noise-reduction bumps, footsteps and parasitic low-frequency noises present on the set.

“It might be pointed out that judgment is required in the use of the Theater Sound Test-Reel, as the product must be evaluated in terms of the material at hand, that is, crowd noises and people talking in loud voices or excited manners

should not be expected to have the same quality and chest tones which are present in conversational dialog in a quiet, intimate scene.

"The Research Council and the Committee have always felt that electrical and acoustical curves furnish valuable means of setting equipment, but that the final criteria should be critical listening tests of the equipment. For this reason all Theater Sound Reproducing Equipment Standards to date have been set up on the basis of listening tests correlated with engineering data.

"One of the purposes of the Standard Electrical Characteristic is to provide a basis for an eventual standard recording characteristic. We believe that the new Theater Sound Test-Reel demonstrates the fact that the recording charac-



FIG. 2. Cathode-Ray Oscilloscope.

teristics of the various studios are very much closer together than they were a year or two ago.

"The material contained in the reel is not necessarily a sample of the best recording available but is typical of the average.

"In an average theater, set to the Standard Electrical Characteristic, the reel will play through entirely upon one fader setting (with, of course, the exception of the Hi-Range print sequence, for which the fader must be raised 6 db)."

Universal A-C Bridge.—To enable the field engineer to measure inductance and capacity as well as resistance, the RCA universal bridge (Fig. 1) is employed. This instrument is invaluable for checking reactors and transformers for shorted turns or other trouble, and for accurately determining values of capacitors. The measuring ranges are 100 μ h to 10h, 10 μ f to 10 μ f, and 1 ohm to 1 megohm. For

higher values of resistance, the test analyzer is employed, since this has ranges up to 10 megohms.

The instrument consists of a variable-ratio-arm Wheatstone bridge having three standards each of inductance, capacity, and resistance. A vacuum-tube 1000-cycle oscillator and a two-stage amplifier, together with their power supply, make up the major part of the equipment. The only additional equipment required is a "null" indicator, for which the power level meter is employed. Power is obtained from any 110 to 120-volt, 25 to 60-cycle source. The complete instrument weighs only 6 pounds.

Cathode-Ray Oscillograph.—Another device which has been in general use for over three years and has proved extremely useful in theater service, is the cathode-ray oscillograph (Fig. 2). This instrument is probably the most versatile device yet developed for the study of radio and audio-frequency phenomena.



FIG. 3. Portable Beat-Frequency Oscillator.

By means of the oscillograph the field engineer can quickly localize sources of hum in the sound systems and check hum patterns, determine where distortion is introduced, check phasing of networks, and perform many other routine checks which up to a few years ago were impossible to do. This instrument weighs 21 pounds complete and is entirely self-contained, requiring only a source of a-c power supply.

Beat-Frequency Oscillator.—For quickly checking the audio-frequency response and power output of a theater sound system, the RCA portable beat-frequency oscillator (Fig. 3) is provided. This instrument is extremely rugged, weighs only 15 pounds, and is remarkably stable for its size. The hum level is 60 db below maximum output.

Besides its use in checking audio amplifiers, it is also extremely valuable for determining source of buzzes, rattles, *etc.*, in stage surroundings and auditorium fixtures. It is also used as a routine check on the loud speaker systems to be sure that the units are free from distortion.

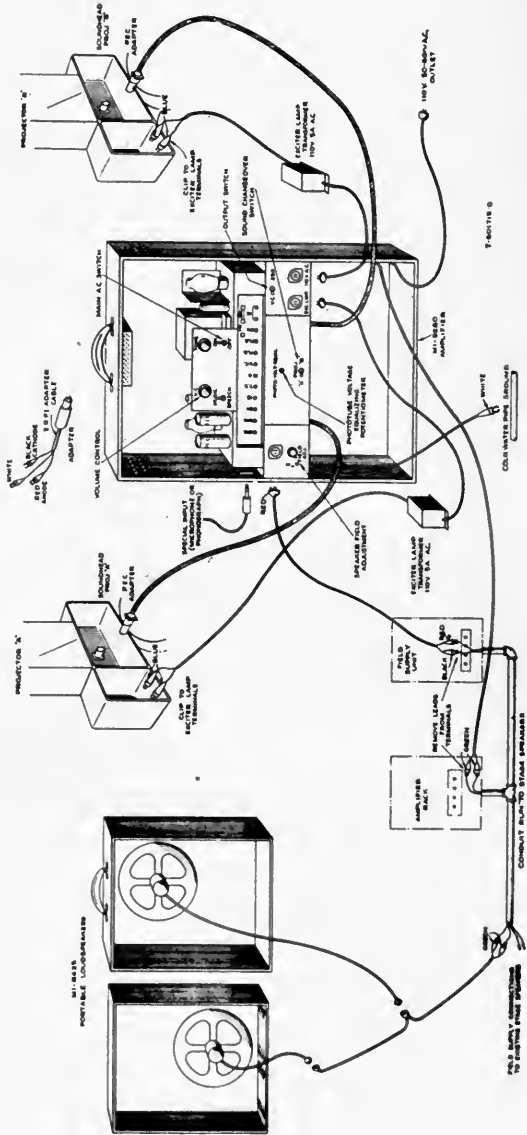

FIG. 4. PG-109-B equipment set-up.

Emergency Amplifier System.—In the latter part of 1936, RCA introduced to exhibitors a complete portable emergency sound system, so designed that it would be possible to keep the show running if every piece of equipment were down except one sound-head and projector (Fig. 4). This system proved so valuable that more than 150 are now located in theaters throughout the country, and besides this nearly every RCA field engineer carries one as standard equipment.

The most recent design incorporates many improvements for greater ease and simplicity in operation. The amplifier and all controls are housed in a small metal cabinet, with all necessary cables for making connections to sound-heads and stage lines. Sufficient audio power is available to carry even the largest theater, and connections can be made to any type of sound equipment regardless of manufacture.

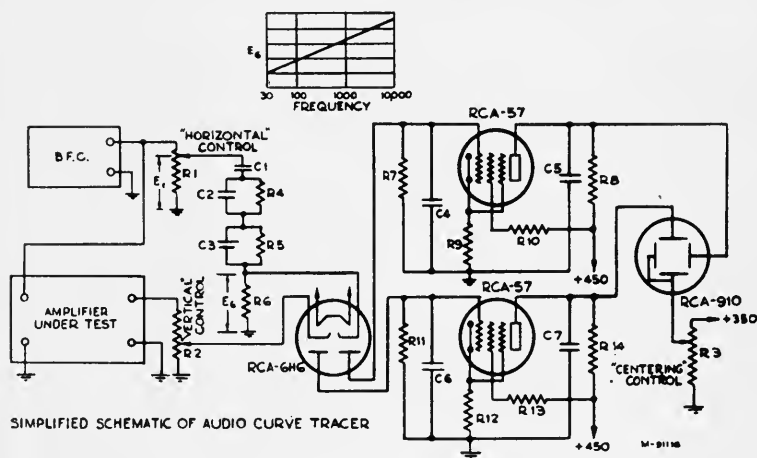

FIG. 5. Audio Curve Tracer, simplified circuit.

SPECIAL EQUIPMENT

While the various pieces of standard equipment already described are usually adequate for routine service work, quite often problems arise which require specialized test equipment. RCA is continually at work developing new test equipment to handle these problems, as well as new equipment and methods to simplify and speed up routine tests.

Audio Curve Tracer.—One of the recently developed instruments in this classification is the audio curve tracer. This is a portable device which traces an amplifier response curve automatically on the screen of a cathode-ray tube. By using a tube with a long-persistence screen, such as the RCA-910, the image is retained long enough for it to be studied, photographed, or a second curve superimposed on it for comparison. With this instrument it is possible to run an accurate frequency response curve in approximately thirty seconds.

Fig. 5 is a schematic drawing showing the operation of the instrument. The output of a beat-frequency oscillator is fed both into the "horizontal control" potentiometer $R-1$ and into the input of the amplifier under test. The voltage developed across $R-1$ is fed through a resistor-capacitor network to ground. The characteristics of this network are such that with a constant voltage $E-1$ impressed across the network, the voltage developed across $R-6$ varies directly as the logarithm of the frequency impressed. This is shown in the small curve above. The voltage $E-6$ is impressed across a diode section of the $RCA-6H6$ tube and is rectified. The rectified voltage causes current to flow through resistor $R-7$ producing a negative bias voltage at the grid of the $RCA-57$ d-c amplifier tube. The greater the voltage $E-6$ becomes the more negative the bias on the $RCA-57$ becomes. The plate supply voltage to the d-c amplifier is 450 volts. The actual voltage at

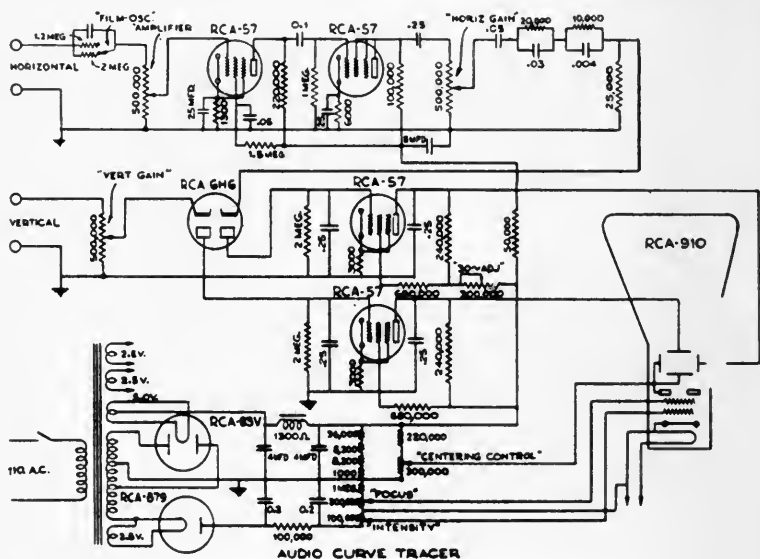

FIG. 6. Overall schematic diagram of complete Audio Curve Tracer.

the plate of this tube is equal to this voltage minus the voltage drop in the plate resistor $R-8$ caused by the flow of plate current. Hence, as the plate current is reduced the drop across the plate resistor is reduced and the voltage at the plate of the tube becomes higher. The plate voltage is applied directly to one of the horizontal deflection plates of the cathode-ray tube. The opposite deflection plate is at some potential above ground which is determined by the setting of the centering control potentiometer $R-3$.

When the beat-frequency oscillator is set at a low frequency the voltage $E-6$ is low. Hence the current through $R-7$ is small and therefore the value of negative bias is small. This causes a large plate current to flow in the $RCA-57$ and reduces the voltage at the plate of the tube because of the large drop in the plate resistor. This reduces the voltage applied to the right deflection plate below that at which

the left is set causing the beam to be deflected to the left (that is, toward the more positive plate).

When the frequency of the oscillator is raised the voltage E_6 goes up, more current passes through $R-7$ producing a higher bias voltage, the plate current of the $RCA-57$ is reduced, and the drop across $R-8$ is very small, leaving the voltage at the plate of the tube and consequently at the right deflection plate higher than the voltage of the left deflection plate. Under this condition the negative beam of electrons is deflected toward the right plate which is now the more positive.

Thus by merely tuning the beat-frequency oscillator through its frequency



FIG. 7. Audio Curve Tracer.

range the electron beam is moved across the screen horizontally with a displacement which is always proportional to the logarithm of the frequency impressed.

The output of the amplifier is fed through the "vertical control" potentiometer $R-2$ to ground. A portion of the output voltage is rectified by the second diode in the $RCA-6H6$, amplified by a d-c amplifier identical to the one already described and applied to the vertical deflection plates. By analysis similar to that for the horizontal deflection circuits, it is evident that an increase in amplifier output will cause an upward deflection of the beam.

Thus, for any given frequency at which the oscillator may be set, the frequency determines the horizontal position of the spot, and the output level of the ampli-

fier determines the vertical position of the spot. Therefore, if the oscillator is swept through its frequency range the spot will trace a response curve of the amplifier under test. Fig. 6 shows the overall schematic diagram of the complete audio curve tracer.

In addition to the beat-frequency oscillator as a source of signal, a continuously variable frequency test-film is available which can be run through the sound-head to produce an overall response curve of the complete sound system.

The "film-oscillator" switch at the input of the horizontal amplifier connects either of two high-frequency boosters in the circuit. In the "oscillator" position a slight rise is added to make up for the reduction in output of the oscillator at the high frequencies. A more pronounced rise is provided in the "film" position to compensate for the optical losses in the sound-head at the high-frequency end.

An additional control, the "30-cycle adjustment," has been added so that the



FIG. 8. Flutter Indicator.

voltage drop at the plate of the horizontal d-c amplifier can be lowered independently of the voltage at the vertical d-c amplifier, making it possible to move the spot horizontally without affecting its vertical position.

Fig. 7 is a picture of the audio curve tracer. This is housed in a carrying case similar to that of the three-inch oscillograph. The front panel contains the "focus" and "intensity" controls, the "horizontal" and "vertical" inputs, the "horizontal gain" and the "vertical gain" controls, the "horizontal amplifier gain" control and the "film-oscillator" compensation switch. The "centering control" and the "30-cycle adjustment" control are screw-driver adjustment controls on the side of the case.

Flutter Indicator.—Early in 1933 RCA introduced the rotary stabilizer sound-head, which revolutionized sound reproduction by minimizing to a large extent the flutter which was characteristic of the earlier types of sound-heads. How-

ever, since there are still thousands of older equipments in use which are subject to flutter trouble, RCA has available a Flutter Indicator which will aid the service engineer in making adjustments to reduce flutter to a minimum (Fig. 8).

Flutter is actually frequency modulation of the reproduced tone caused by irregular motion of the film past the scanning beam; hence any one of several frequency-discriminating circuits may be used to detect these irregularities.

In the past few years, several different types of flutter-measuring devices have been built. Most of these employ circuits which are quite similar to those used in automatic frequency-control circuits used in broadcast receivers, or frequency-deviation meters used in transmitting stations. While these instruments are extremely accurate, they require the use of one or more vacuum-tubes together with associated power supply circuits. This reduces the portability and hence makes the units unsuitable for field work.

The discriminating network used in this instrument is merely the familiar Wheatstone bridge used as an impedance bridge with reactive impedances in two of the legs. The constants have been chosen so that when a 3000-cycle signal is fed into the network it can be balanced, and a meter placed across the network will read zero. If the frequency of the input signal varies above and below 3000 cycles, the network will become unbalanced by an amount that is proportional to the variation and the meter will show a corresponding deflection.

A specially recorded 3000-cycle film with low flutter content is run through the sound-head under test and the flutter indicator is connected to the output of the system amplifier. Any variations in output can be measured directly on the meter.

The input transformer has several impedance taps, so this instrument can properly terminate the system amplifier without the use of additional load resistors. An input control provides vernier adjustment of the input level to the measuring network. The "read-calibrate" switch allows the meter to be used for calibrating the input to the measuring network or for reading the flutter voltage developed across the output of the network. Two ranges of sensitivity are made available through the use of the range selector switch. These ranges are 0.5 per cent full scale or 2 per cent full scale. Resistance and capacity balance controls allow the resonance frequency of the measuring network to be shifted slightly to compensate for slight variations in speed between various sound-heads. The meter is a 5000-ohm rectox type volume indicator with a scale that is hand-calibrated directly in per cent flutter.

By using this instrument as a guide in adjusting the tension in the sound-gates of older types of sound-heads, it has been possible to reduce the flutter from as much as 2 per cent to as little as 0.3 per cent.

Scanning Illumination Test-Track.—Another new tool, which is available through the Academy of Motion Picture Arts and Sciences, to give the field engineer a better check on the operation of the theater sound system is the scanning illumination test-track.

This film is made up of seventeen consecutive sound-tracks, each of which is displaced a different distance from the guided edge of the film. The individual tracks are unilateral tracks approximately 7 mils in width and modulated approximately 100 per cent at 1000 cycles. The distance between the centerlines of the consecutive tracks is 6 mils, allowing a slight overlap from one track to the

other. The centerline of the first track occurs at approximately 197 mils from the edge of the film and the centerline of the last track 292 mils from the edge of the film, and the total track width is approximately 110 mils. Each track announces itself by number at the start, and the length of steady-state condition is 10 feet with 2 feet allowed for moving from one track to the next and 1 foot allowed for the announcement. This makes a total of 13 feet for each of seventeen sections.



FIG. 9. Sound-Level Meter.

A single running of this film provides the following information:

- (1) The length of the slit
- (2) The uniformity of illumination across the slit
- (3) The approximate amount of weave in the machine

As an example of the information obtained from running this film, it was run through an older type equipment and the following facts were established: The effective length of the slit was approximately 73 mils; the illumination across the slit was uniform within ± 1 db; and the weave in the machine was approximately 6 mils.

Sound-Level Meter.—While listening tests in theaters are final criteria for good sound reproduction, very often acoustic response readings taken in the auditorium will indicate where changes are necessary to improve quality. RCA has employed

the General Radio 759-A sound level meter (Fig. 9) for this purpose since the early part of 1937. In addition, it is extremely useful for checking noise levels in projection rooms and the theater proper, for checking extraneous noise produced by fans in air-conditioning systems, and the effectiveness of vibration insulation of power equipment.

For checking acoustic response of speaker systems, a warble-tone frequency reel is employed as a source of signal, to reduce as much as possible the effects of standing waves in the theater. The microphone is set up at various points throughout the theater, and then readings are taken from 30 cycles to 9400 cycles at each station. The plotted curves so obtained indicate approximately the acoustic response in various sections of the theater, and this can usually be confirmed by listening tests.

On the basis of the acoustic response so obtained, adjustments can be made for proper sound quality from the speaker system. This procedure has been used in numerous theaters and the results as compared to listening tests were very gratifying.



FIG. 10. Vibration Pick-Up.

This device is also very valuable in checking the sound distribution throughout the auditorium. Response curves run at several points quickly show up any deficiencies. The speakers can be accurately angled on the basis of such readings to give the optimum sound distribution.

ASSOCIATED EQUIPMENT

Other test instruments have been developed by various branches of RCA for specific applications. These are often used for theater work in routine service or solving special problems. One of these is the RCA vibration pick-up (Fig. 10).

Vibration Pick-Up.—This unit, with its associated equipment, is very useful in locating defective gears, bearings, or other moving parts. Such defects usually show up as “knocks” occurring at regular intervals, or as vibrations at an audio frequency. If the approximate location and the frequency of the “vibration” can be determined, the exact location of the defect is rather easy to find.

The output of this vibration pick-up is fed into an amplifier and in turn to the vertical plates of a cathode-ray oscillograph. A prod is provided on the vibration pick-up for prodding around the sound-head until the approximate source of the vibration is located, as indicated by a maximum deflection on the oscillograph screen.

If the frequency of this vibration or knock is known the problem is still further simplified. The frequency can be determined by using the cathode-ray oscillograph externally synchronized by an audio beat-frequency oscillator or an RCA synchronizing generator.



Fig. 11. Ultrasensitive D-C Meter.

If the synchronizing generator is used, it is coupled to the projector crank shaft or to a sound-head sprocket shaft. It generates a synchronizing voltage at intervals which are directly related to the rpm of the shaft. The synchronizer also provides a movable marker voltage which can be impressed on the signal under observation and gives a means of marking the oscillograph trace with respect to the angular position of the shaft.

Knowing the rpm of the motor and sound-head sprockets, the problem is still further reduced and can be solved by associating the frequency of knock or

vibration with the rpm of the moving parts in the vicinity of the source of vibration.

Ultrasensitive D-C Meter.—Another instrument developed by RCA for use in laboratories and handling special field measurements is the ultrasensitive d-c meter (Fig. 11). This is a ruggedly built, portable precision device, for measuring small values of current and voltage, and a wide range of resistance.

Current measurements as low as 0.02 microampere and up to 10,000 microamperes can be made over twelve different scale ranges. D-c voltage measurements from 0.1 volt to 500 volts over eight scale ranges can be made. Resistance values from 0.1 megohm up to 200,000 megohms can be checked with this instrument.

The instrument consists of a multiplicity of input circuits, a three-stage d-c feedback amplifier, and a meter circuit. The amplifier is so designed that the meter can not burn out or even deviate in calibration through overload unless the sensitivity push-button is held down.

The sensitivity of the instrument approaches that of the average reflecting galvanometer. The overall accuracy for all ranges of current or voltage measurements is ± 2 per cent of full scale at ambient temperatures of 50° to 100° F and normal humidity. For resistance measurements the maximum deflection error is ± 0.1 inch at mid-scale and approaches zero at ends of the scale.

The instrument is particularly useful in theater sound work for measuring photocell currents, leakage currents between tube electrodes, and between circuit elements. The unusually high input resistance, five megohms or better, on all ranges of the voltmeter circuit enables accurate measurement of d-c voltages across high-impedance circuits such as those existing between tube electrodes or across circuit elements such as bias-resistors.

OFFICERS AND GOVERNORS OF THE SOCIETY

1940



D. E. HYNDMAN
Engineering Vice-President



N. LEVINSON
Executive Vice-President



J. I. CRABTREE
Editorial Vice-President



E. A. WILLIFORD
President



A. S. DICKINSON
Financial Vice-President



S. K. WOLF
Past-President



W. C. KUNZMANN
Convention Vice-President



J. FRANK, JR.
Secretary



R. O. STROCK
Treasurer



M. C. BATSEL
Governor



A. N. GOLDSMITH
Governor



H. GRIFFIN
Governor



H. G. TASKER
Governor



A. C. HARDY
Governor



J. A. DUBRAY
*Chairman, Mid-West
Section*



P. J. LARSEN
*Chairman, Atlantic
Coast Section*



L. L. RYDER
*Chairman, Pacific
Coast Section*

SECTIONS OF THE SOCIETY

(Atlantic Coast)

*P. J. LARSEN, *Chairman*

D. E. HYNDMAN, *Past-Chairman*

**R. O. STROCK, *Manager*

*J. A. MAURER, *Sec.-Treas.*

*H. GRIFFIN, *Manager*

(Pacific Coast)

*L. L. RYDER, *Chairman*

J. O. AALBERG, *Past-Chairman*

**P. MOLE, *Manager*

*A. M. GUNDELFINGER, *Sec.-Treas.*

*K. F. MORGAN, *Manager*

*W. C. MILLER, *Manager*

**H. W. MOYSE, *Manager*

*J. DURST, *Manager*

**H. REMERSHEID, *Manager*

(Mid-West)

*J. A. DUBRAY, *Chairman*

S. A. LUKES, *Past-Chairman*

*O. B. DEPUE, *Manager*

*I. JACOBSEN, *Sec.-Treas.*

**C. H. STONE, *Manager*

* Term expires December 31, 1940.

** Term expires December 31, 1941.

COMMITTEES OF THE SOCIETY

(Correct to March 25th; additional appointments or changes may be made at any time during the year, as necessity or expediency may require.)

ADMISSIONS

(East Coast)

G. FRIEDL, JR., *Chairman*

R. B. AUSTRIAN
A. S. DICKINSON

H. GRIFFIN
D. E. HYNDMAN

L. A. JONES
P. J. LARSEN

(West Coast)

E. HUSE, *Chairman*

N. LEVINSON

H. W. REMERSHEID
L. L. RYDER

H. G. TASKER

BOARD OF EDITORS

J. I. CRABTREE, *Chairman*

J. G. FRAYNE
A. N. GOLDSMITH

A. C. HARDY
L. A. JONES
E. W. KELLOGG

G. E. MATTHEWS
T. E. SHEA

COLOR COMMITTEE

G. F. RACKETT, *Chairman*

F. T. BOWDITCH
L. E. CLARK

R. M. EVANS

A. M. GUNDELFINGER
A. C. HARDY

CONVENTION

W. C. KUNZMANN, *Chairman*

H. BLUMBERG
H. GRIFFIN

J. HABER
S. HARRIS

O. F. NEU
L. L. RYDER

EUROPEAN ADVISORY COMMITTEE

F. H. HOTCHKISS, *Chairman*

J. J. C. HARDENBERG

D. McMASTER

H. WARNCKE

EXCHANGE PRACTICE

G. R. GIROUX, *Chairman*A. S. DICKINSON
T. FAULKNER
K. HADDOWS. HARRIS
L. B. ISAAC
H. C. KAUFMAN
J. P. McLEODN. F. OAKLEY
A. W. SCHWALBERG
J. SICHELMAN

FELLOW MEMBERSHIP

A. C. HARDY, *Chairman*

A. N. GOLDSMITH

H. T. KALMUS
C. E. K. MEES

E. C. WENT

JOURNAL AWARD

J. G. FRAYNE, *Chairman*

G. A. CHAMBERS

G. L. DIMMICK
R. E. FARNHAM

L. L. RYDER

LABORATORY PRACTICE

H. E. WHITE, *Chairman*J. O. BAKER
L. A. BONN
J. A. DUBRAY
O. B. DEPUE
J. G. FRAYNEG. H. GIBSON
E. HUSE
T. M. INGMAN
C. L. LOOTENS
A. J. MILLER
R. F. MITCHELLH. W. MOYSE
J. M. NICKOLAUS
N. F. OAKLEY
W. A. SCHMIDT
J. H. SPRAY

NON-THEATRICAL EQUIPMENT

J. A. MAURER, *Chairman*J. G. BLACK
F. E. CARLSON
N. B. GREENJ. A. HAMMOND
M. HOBART
R. KINGSLAKE
L. R. MARTINR. F. MITCHELL
L. T. SACHTLEBEN
A. SHAPIRO

PAPERS

S. HARRIS, *Chairman (East Coast)*L. A. AICHOLTZ, *Chairman (West Coast)*P. ARNOLD
C. N. BATSEL
L. N. BUSCH
O. O. CECCARINI
G. A. CHAMBERS
A. C. COOK
L. J. J. DIDIEE
A. C. DOWNES
R. E. FARNHAMC. FAULKNER
C. FLANNAGAN
L. D. GRIGNON
E. W. KELLOGG
G. E. MATTHEWS
R. F. MITCHELL
W. A. MUELLER
W. H. OFFENHAUSERF. H. RICHARDSON
W. H. ROBINSON
C. R. SAWYER
J. STEWART
H. G. TASKER
R. TOWNSEND
P. R. VON SCHROTT
I. D. WRATTEN
C. K. WILSON

MEMBERSHIP AND SUBSCRIPTION

E. R. GEIB, *Chairman**Alabama*

H. F. ANDERSON

California

J. O. AALBERG
 C. W. HANDLEY
 E. HUSE
 R. H. McCULLOUGH
 G. A. MITCHELL
 P. MOLE
 K. F. MORGAN
 W. A. MUELLER
 H. G. TASKER

Georgia

N. WEIL
 H. F. ANDERSON

Illinois

H. A. DEVRY
 B. J. KLEERUP
 S. A. LUKES
 J. M. SCHAEFER
 J. H. TOLER
 A. ACKLEY
 A. L. MONSON

Massachusetts

J. S. CIFRE
 S. SUMNER
 A. B. WEST
 T. C. BARROWS

Australia

H. C. PARRISH

Austria

P. R. VON SCHROTT

Canada

F. C. BADGLEY
 G. H. BATTLE
 C. A. DENTELBECK
 B. E. NORRISH

China

R. E. O'BOLGER

Michigan

J. F. STRICKLER

Minnesota

C. L. GREENE
 R. H. RAY

Missouri

J. S. COPLEY
 L. E. POPE

New York

A. BECKER
 F. E. CAHILL
 A. A. COOK
 A. S. DICKINSON
 J. J. FINN
 J. FRANK, JR.
 S. HARRIS
 D. E. HYNDMAN
 W. H. INGRAM
 O. E. MILLER
 F. H. RICHARDSON
 P. D. RIES
 C. J. STAUD
 L. M. TOWNSEND
 J. S. WARD

England

W. F. GARLING
 R. G. LINDERMAN
 E. McMASTER
 R. TERRANEAU

France

L. J. J. DIDIEE
 I. G. EGROT
 F. H. HOTCHKISS

Germany

W. F. BIELICKE

Hawaii

L. LA CHAPELLE

Ohio

C. C. DASH
 R. H. GILES
 V. C. WELMAN
 J. GELLMAN

Pennsylvania

H. BLOOMBERG
 A. GOODMAN
 I. SAMUELS

Texas

H. H. FRASCH

District of Columbia

H. T. COWLING
 R. EVANS
 N. D. GOLDEN
 F. J. STORTY

Traveling

E. AUGER
 C. BRENKERT
 F. HOHMEISTER
 W. C. KUNZMANN
 D. McRAE
 O. F. NEU
 H. H. STRONG

Russia

E. G. JACHONTOW

Holland

J. VAN BREUKELEN

India

G. D. LAL
 H. S. MEHTA
 M. L. MISTRY

Japan

T. NAGASE
 Y. OWAWA

New Zealand

C. BANKS

PRESERVATION OF FILM

M. E. GILLETTE, *Chairman*

J. E. ABBOTT
 J. G. BRADLEY
 J. I. CRABTREE

A. S. DICKINSON
 R. M. EVANS
 C. L. GREGORY

T. RAMSAYE
 W. A. SCHMIDT
 V. B. SEASE

PROGRESS

J. G. FRAYNE, *Chairman*

G. L. DIMMICK

F. DURST

R. E. FARNHAM

PROGRESS AWARD

N. LEVINSON, *Chairman*

A. C. HARDY

E. HUSE
 E. W. KELLOGG

K. F. MORGAN

PUBLICITY

J. HABER, *Chairman*

L. A. AICHOLTZ
 J. R. CAMERON

J. J. FINN
 S. HARRIS

P. A. MCGUIRE
 F. H. RICHARDSON

SOUND

H. G. TASKER, *Chairman*

J. O. AALBERG
 L. A. AICHOLTZ
 M. C. BATSEL
 D. B. BELL
 D. BLUMBERG
 F. E. CAHILL
 J. DURST

C. FLANNAGAN
 G. FRIEDL, JR.
 E. H. HANSEN
 L. B. ISAAC
 J. P. LIVADARY
 J. A. MAURER
 R. MCCULLOUGH

B. F. MILLER
 W. C. MILLER
 K. F. MORGAN
 H. RUBIN
 G. SAWYER
 W. V. WOLFE
 E. C. ZRENNER

STANDARDS

D. B. JOY, *Chairman*

P. H. ARNOLD
 H. BAMFORD
 M. C. BATSEL
 M. R. BOYER
 F. E. CARLSON
 E. K. CARVER
 L. W. DAVEE
 A. C. DOWNES
 J. A. DUBRAY
 A. F. EDOUART

G. FRIEDL, JR.
 P. C. GOLDMARK
 A. N. GOLDSMITH
 H. GRIFFIN
 A. C. HARDY
 E. HUSE
 P. J. LARSEN
 C. L. LOOTENS
 J. A. MAURER
 G. S. MITCHELL

K. F. MORGAN
 R. MORRIS
 W. H. OFFENHAUSER
 G. F. RACKETT
 W. B. RAYTON
 E. C. RICHARDSON
 H. RUBIN
 O. SANDVIK
 J. L. SPENCE
 H. E. WHITE

STUDIO LIGHTING

E. C. RICHARDSON, *Chairman*

F. E. CARLSON	R. E. FARNHAM	C. W. HANDLEY
F. M. FALGE		D. B. JOY

TELEVISION

P. C. GOLDMARK, *Chairman*

H. BAMFORD	H. GRIFFIN	R. MORRIS
R. M. CORBIN	P. J. LARSEN	A. MURPHY
A. S. DICKINSON	H. B. LUBCKE	O. SANDVIK
A. N. GOLDSMITH	J. A. MAURER	H. E. WHITE
T. T. GOLDSMITH		

THEATER ENGINEERING

A. N. GOLDSMITH, *Chairman**(Projection Practice Sub-Committee)*H. RUBIN, *Sub-Chairman*

T. C. BARROWS	M. GESSIN	H. MORGAN
H. D. BEHR	A. GOODMAN	E. R. MORIN
F. E. CAHILL, JR.	H. GRIFFIN	J. R. PRATER
C. C. DASH	S. HARRIS	F. H. RICHARDSON
A. S. DICKINSON	J. HOPKINS	J. J. SEFING
J. K. ELDERKIN	C. HORSTMAN	V. A. WELMAN
R. R. FRENCH	L. B. ISAAC	H. E. WHITE
E. R. GEIB	P. J. LARSEN	A. T. WILLIAMS
	J. H. LITTENBERG	

*(Theater Design Sub-Committee)*B. SCHLANGER, *Sub-Chairman*

F. W. ALEXA	K. C. MORRICAL	A. L. POWELL
J. S. CLARKE, JR.	E. R. MORIN	A. L. RAVEN
J. FRANK, JR.	I. L. NIXON	R. F. ROSS
S. HARRIS	C. C. POTWIN	E. S. SEELEY
C. HORSTMAN		J. J. SEFING

SMPE REPRESENTATIVES TO OTHER ORGANIZATIONS

American Documentation Institute.

S. K. WOLF

Sectional Committee on Motion Pictures, ASA.

E. K. CARVER
A. N. GOLDSMITH
H. G. TASKER

Sectional Committee on Photography, ASA.

J. I. CRABTREE

Inter-Society Color Council.

R. M. EVANS
G. F. RACKETT
F. T. BOWDITCH

COMMITTEES OF THE SOCIETY

AMERICAN STANDARDS ASSOCIATION
SECTIONAL COMMITTEE ON MOTION PICTURES (Z22)**A. N. GOLDSMITH, *Chairman*

J. O. AALBERG	F. EDOUART	G. S. MITCHELL
P. H. ARNOLD	E. W. ELY	O. F. NEU
M. C. BATSEL	R. E. FARNHAM	N. F. OAKLEY
F. G. BEACH	C. FLANNAGAN	D. PALFREYMAN
*(R. G. HOLSLAG)	J. G. T. GILMOUR	A. R. SMALL
B. H. CARROLL	H. GRIFFIN	*(G. W. BOOTH)
**E. K. CARVER	F. L. HERRON	J. L. SPENCE
W. CLARK	L. A. JONES	J. O. AALBERG
A. S. DICKINSON	D. B. JOY	**H. G. TASKER
J. A. DUBRAY	*(E. A. WILLIFORD)	G. H. WORRALL
	G. A. MITCHELL	
	*(J. RUTTENBERG)	

* Alternate.

** SMPE delegates.

CURRENT LITERATURE OF INTEREST TO THE MOTION PICTURE ENGINEER

The editors present for convenient reference a list of articles dealing with subjects cognate to motion picture engineering published in a number of selected journals. Photostatic copies may be obtained from the Library of Congress, Washington, D. C., or from the New York Public Library, New York, N. Y. Micro copies of articles in magazines that are available may be obtained from the Bibliofilm Service, Department of Agriculture, Washington, D. C.

Acoustical Society of America, Journal

11 (January, 1940), No. 3

Review of Cardioid Type Unidirectional Microphones
(pp. 296-302)

R. P. GOLVER

Application of Piezoelectric Vibration Pick-Ups to
Measurement of Acceleration, Velocity and Dis-
placement (pp. 303-307)

B. BAUMZWEIGER

Loudness Level to Loudness Conversion Chart (pp.
308-310)

P. H. GEIGER

On the Theory of Fluctuations in the Decay of Sound
(pp. 324-332)

R. C. JONES

Noise and Vibration Isolation (pp. 341-345)

H. A. LEEDY

Sound in the Theater (pp. 346-351)

H. BURRIS-MEYER

American Cinematographer

21 (February, 1940), No. 2

Studying Photoelectric Exposure Metering (pp. 64-65),
Pt. III

D. NORWOOD

New Gadget Coordinates Meter, Makeup, Lighting
(pp. 67-88)

J. WALKER

Handicaps Against India's Film Production (pp.
84-85), Pt. I

F. BERKO

British Journal of Photography

86 (December 29, 1939), No. 4156

Progress in Colour (pp. 758-760)

87 (January 5, 1940), No. 4157

Progress in Colour (pp. 7-8)

87 (January 12, 1940), No. 4158

Improved Tri-Chromatic Separation (pp. 15-17)

J. H. COOTE

Progress in Colour (pp. 17-19)

Educational Screen

29 (January, 1940), No. 1

Motion Pictures Not for Theaters (pp. 16-18), Pt. 15

A. E. KROWS

Electronics and Television and Short-Wave World

13 (January, 1940), No. 143

Construction of Apparatus for Recording Sound on Steel Wire (pp. 4-10)

R. L. MANSI

The Television Range Finder (p. 19)

Fernseh

1 (December, 1939), No. 6

Das Zwischenfilmverfahren (Intermediate Film Television) (pp. 201-210), Pt. III

G. SCHUBERT,
W. DILLENBURGER,
AND H. ZSCHAU

Brückenmodulationsschaltungen (Bridge Circuits for Modulating Purposes) (pp. 211-215)

W. DILLENBURGER

Gesichtspunkte zum Bau von Grossprojektionsempfängern (Television Projection Tube Receivers) (pp. 216-219)

T. MULERT

Ueber Photozellen mit Sekundarelektronenvervielfachern (Photoelectric Cells with Secondary Emission Multiplier) (pp. 226-230)

W. HARTMANN

Kinotechnik

21 (December, 1939), No. 12

Ein abgekürztes Verfahren zur betriebsmassigen Bestimmung des Donnereffektes (A Quick Method for Determination of the "Donnereffekt" in the Plant) (pp. 263-265)

H. ORLICH AND
K. ROWER

Material- und Arbeitersparnis bei der Nachbearbeitung von Bildtonfilmen (Saving of Material and Labor During After-Treatment of Sound Film) (pp. 265-268)

J. BALTZER

Arbeit- und filmsparende Umroller für die Kinotechnik (Film Rewinder for Motion Pictures) (pp. 268-269)

H. VOIGT

Bericht über die Ermittlung der Grossenverhältnisse der deutschen Filmtheater als Grundlage für die Klimatisierung (Report on Relative Size of German Motion Picture Theaters as Basis of Air Conditioning) (pp. 269-270)

H. FICHTNER

Die Oberfläche des allernächsten Fixsternes (Surfaces of the Newest Fixed Stars) (pp. 271-272)

H. I. GRAMATZKI

Institute of Radio Engineers, Proceedings

28 (January, 1940), No. 1

A New Standard Volume Indicator and Reference Level (pp. 1-17)

H. A. CHINN,
D. K. GANNETT,
AND R. M. MORRIS

International Photographer

11 (January, 1940), No. 12

Are Photometers Necessary? (pp. 6, 8)

History of Negro Motion Pictures (pp. 16-17)

Fluorescent Lamp as a Key Light (pp. 14-15)

S. ZIPSER

J. ASENSIO

G. KORNMANN AND

F. POWOLNY

12 (February, 1940), No. 1

Professional Type Exposure Meters (p. 8)

New High Speed Sheet Film (Eastman Tri-X Panchromatic) (pp. 21-22)

S. ZIPSER

International Projectionist

14 (December, 1939), No. 11

Three-Dimensional Motion Pictures: A Review and Forecast (pp. 19-21)

Novel Cinetymer Reel Footage Indicator (pp. 22-23)

J. T. RULE

Journal of Applied Physics

11 (January, 1940), No. 1

Theory of the Photographic Latent-Image Formation (pp. 18-34)

Physics in Color Photography (pp. 46-55)

The Design of Wide-Aperture Photographic Objectives (pp. 56-69)

J. H. WEBB

D. L. MACADAM

R. KINGSLAKE

Photographische Industrie

37 (December 20, 1939), No. 51

Vereinfachte Beleuchtungsberechnung bei der Kino-projection (Simplified Illumination Computation in Motion Picture Projectors) (pp. 1231-1232)

P. HATSCHKEK

1940 SPRING CONVENTION

SOCIETY OF MOTION PICTURE ENGINEERS

CHALFONTE-HADDON HALL, ATLANTIC CITY, N. J.
APRIL 22-25, INCLUSIVE

Officers and Committees in Charge

E. A. WILLIFORD, *President*
S. K. WOLF, *Past-President*
W. C. KUNZMANN, *Convention Vice-President*
J. I. CRABTREE, *Editorial Vice-President*
S. HARRIS, *Chairman, Papers Committee*
J. HABER, *Chairman, Publicity Committee*
H. GRIFFIN, *Chairman, Convention Projection*
E. R. GEIB, *Chairman, Membership Committee*
H. BLUMBERG, *Chairman, Local Arrangements*

Reception and Local Arrangements

	HARRY BLUMBERG, <i>Chairman</i>	
M. C. BATSEL	E. O. WILSCHKE	E. W. KELLOGG
A. B. FREEMAN	W. J. CHARLES	H. WALTERS
C. A. SEUBERT	M. LEWIS	F. B. EVANS
C. W. TREEN	W. CONNER	L. RATENER

Registration and Information

	W. C. KUNZMANN, <i>Chairman</i>	
E. R. GEIB	J. FRANK, JR.	F. HOHMEISTER

Hotel and Transportation

	E. O. WILSCHKE, <i>Chairman</i>	
S. ABRAMS	C. A. SEUBERT	J. DEFRENES
C. COHEN	B. BLUMBERG	H. J. MAIRE
F. J. BETTELLI	C. PRESGRAVE	G. L. DIMMICK

Publicity

	J. HABER, <i>Chairman</i>	
S. HARRIS		P. A. MCGUIRE
J. J. FINN		F. H. RICHARDSON

Convention ProjectionH. GRIFFIN, *Chairman*

M. C. BATSEL	H. BLUMBERG	E. O. WILSCHKE
M. LEWIS	H. WALTERS	W. J. CHARLES
C. W. TREEN	F. HOHMEISTER	A. B. FREEMAN

Officers and Members Projectionists Local 310, IATSE

Banquet and DanceM. C. BATSEL, *Chairman*

H. BLUMBERG	E. W. KELLOGG	B. BLUMBERG
W. J. CHARLES	H. WALTERS	A. B. FREEMAN
E. O. WILSCHKE	O. F. NEU	C. W. TREEN

Ladies' Reception CommitteeMRS. O. F. NEU, *Hostess**assisted by*

MRS. M. C. BATSEL	MRS. E. O. WILSCHKE
MRS. H. BLUMBERG	MRS. C. W. TREEN
MRS. A. B. FREEMAN	MRS. B. BLUMBERG
MISS L. A. MOYER, <i>Social Director</i> , Chalfonte-Haddon Hall	

Headquarters

Headquarters.—The headquarters of the Convention will be the Chalfonte-Haddon Hall, where excellent accommodations have been assured, and a reception suite will be provided for the Ladies' Committee.

Reservations.—Early in March room reservation cards were mailed to members of the Society. These cards should be returned as promptly as possible in order to be assured of satisfactory accommodations.

Hotel Rates.—Special rates have been guaranteed by the Chalfonte-Haddon Hall to SMPE delegates and their guests. These rates, European plan, will be as follows:

	<i>Four Lower Floors</i>	<i>Ocean View</i>	<i>Ocean Front</i>
Room for one person	\$ 3.50	\$ 4.00	\$ 5.00
Room for two persons	6.00	7.00	8.00
Parlor Suite, for one	10.00	12.00	14.00
Parlor Suite, for two	14.00	16.00	18.00

(All bathrooms at Haddon Hall have hot and cold running fresh and salt water)

If American plan rates are desired the hotel room clerk should be advised accordingly when registering. An additional charge of \$3 per day per person will be added to the above-listed European rates for three daily meals, American plan. Members and guests registering at the hotel on the American plan will pay only \$3 for the SMPE banquet scheduled at Haddon Hall on Wednesday

evening, April 24th. If registered on the American plan, the clerk at registration headquarters should be advised accordingly when procuring your banquet tickets.

Parking.—Parking accommodations will be available to those who motor to the Convention at the Chalfonte-Haddon Hall garage, at the rate of 50¢ for day parking or \$1.25 for twenty-four hours. These rates include pick-up and delivery of car.

Registration.—The registration and information headquarters will be located at the entrance of the *Viking Room* on the ballroom floor where the technical and business sessions will be held. All members and guests attending the Convention are expected to register and receive their badges and identification cards required for admission to all the sessions of the Convention, as well as to several motion picture theaters in the vicinity of the Hotel.

Technical Sessions

The technical sessions of the Convention will be held in the *Viking Room* of the Hotel. The Papers Committee plans to have a very attractive program of papers and presentations.

Luncheon and Banquet

The usual informal get-together luncheon will be held in the *Benjamin West Room* of Haddon Hall on Monday, April 22nd, at 12:30 p.m. The forty-sixth Semi-Annual Banquet and Dance of the Society will occur on the evening of Wednesday, April 24th, in the *Rulland Room* of Haddon Hall—an evening of dancing and entertainment for members and guests.

Ladies' Program

A specially attractive program for the ladies attending the Convention is being arranged by Mrs. O. F. Neu, *Hostess*, and the Ladies' Committee. A suite will be provided in the Hotel where the ladies will register and meet for the various events upon their program.

Entertainment

At the time of registering, passes will be issued to the delegates of the Convention admitting them to the *Apollo* and *Strand* Theaters, by courtesy of Weiland and Lewis Theaters, Inc., and the *Stanley* and *Virginia* Theaters, courtesy of Warner Bros. Theaters. These theaters are in the vicinity of the Hotel.

Atlantic City's boardwalk along the beach offers a great variety of interests, including many attractive shops and places of entertainment.

W. C. KUNZMANN,
Convention Vice-President

**ABSTRACTS OF PAPERS OF THE
 SPRING CONVENTION
 AT
 ATLANTIC CITY, N. J.
 APRIL 22-25, 1940**

The Papers Committee submits for the consideration of the membership the following abstracts of papers to be presented at the Spring Convention. It is hoped that the publication of these abstracts will encourage attendance at the meeting and facilitate discussion. The papers presented at Conventions constitute the bulk of the material published in the Journal. The abstracts may therefore be used as convenient reference until the papers are published.

J. I. CRABTREE, *Editorial Vice-President*

S. HARRIS, *Chairman, Papers Committee*

L. A. AICHOLTZ, *Chairman, West Coast Papers Committee*

P. ARNOLD	R. E. FARNHAM	W. H. OFFENHAUSER
C. N. BATSEL	C. FAULKNER	F. H. RICHARDSON
L. N. BUSCH	C. FLANNAGAN	W. H. ROBINSON
O. O. CECCARINI	L. D. GRIGNON	C. R. SAWYER
G. A. CHAMBERS	E. W. KELLOGG	J. STEWART
A. A. COOK	G. E. MATTHEWS	H. G. TASKER
L. J. J. DIDIEE	R. F. MITCHELL	R. TOWNSEND
A. C. DOWNES	W. A. MUELLER	C. K. WILSON
	I. D. WRATTEN	

The Control of Sound in Theaters and Preview Rooms; C. C. Potwin, *Electrical Research Products, Inc.*, New York, N. Y.

Acoustical science can now be applied to better advantage than ever before in the planning of modern motion picture theaters. A broader understanding of the purposes and principles of acoustical design and treatment is needed, however, to make this application universal. The Society is in a position to do much toward fulfilling this need.

Greater attention should be given to the design and development of the basic theater structure. The shaping of surfaces for the control of sound reflections is effective and can be kept within a desirable architectural limit. Furthermore, such shaping can be made to function successfully if the basic design is developed to control reverberation.

The all too prevalent idea that "the more acoustical material used, the better the results" should be discouraged. Acoustical materials can be used more efficiently if they are distributed asymmetrically with due regard to the geometry of the reflecting surfaces. In general, they should not be concentrated in large compact areas on single surfaces. This principle of treatment and its effect upon the acoustical characteristics of theaters is discussed.

Instrumental measurements of the effect of surface parallelism upon the frequency reverberation characteristic of a rectangular room are shown. The results are of particular interest with respect to the acoustical treatment of preview rooms.

Current Practices in Blooping Sound-Film; W. H. Offenhauser, Jr., *Bernot-Maurer Corp.*, New York, N. Y.

A review of our dimensional standards fails to indicate any attempt in the past to standardize sound-track bloop. While it is true that there is relatively little difficulty due to bloop at the present time, this condition appears to be due to the fact that each producing organization has more or less independently arrived at some rule-of-thumb solution to its particular problem rather than a result of any directed effort on the part of the industry as a whole.

The volume of film affected is already very large and all indications seem to point to a substantial increase in the future. With this increase in prospect, it appears that an analysis of the subject is justified in order that standardization may be accomplished when, as, and if desirable.

The criteria at the present time are almost entirely empirical; the common tests are (1) peak volume indicator and (2) listening. This has resulted in a wide variety of bloop in use; a reduction in the number of sizes and types seems desirable in the interest of simplification. For single-track negative bloop punches this is especially important.

In actual use, the length of the bloop punch varies from as small as 0.330 inch in one case to as large as 0.965 inch in another. A length of 0.500 inch may be considered to represent "average" practice. There is almost complete agreement on the following characteristics of bloop punches: (1) The punch should be sharp. (2) In the case of the triangle or trapezium types, there should be rounded corners at the base of the triangle.

There is no similar agreement in the use of bloop for sound positives; in the case of release prints, this matter is not especially pressing since release negatives are usually re-recorded and have few if any splices.

An Investigation of the Influence of the Negative and Positive Materials on Ground Noise; O. Sandvik and W. K. Grimwood, *Kodak Research Laboratories*, Rochester, N. Y.

This paper deals with the effect of the negative sound-track upon the ground-noise of the print. Data are presented showing the influence of negative density and negative gamma on print ground noise for fine, medium, and course-grain negative emulsions.

The Effects of Ultraviolet Light upon Variable-Density Recording; J. G. Frayne and V. Pagliarulo, *Electrical Research Products, Inc.*, Hollywood, Calif.

The effect of using ultraviolet filters upon the gamma of negative and positive development is discussed. The effect of ultraviolet light upon image quality is discussed, and a mathematical analysis is given explaining the existence of spurious side-images found in white-light recording on clear-base variable-density negatives. Low-end frequency rise, attributed to existence of these side-images, is eliminated by recording with ultraviolet. Reduction in wave-shape distortion as

well as improvement in high-frequency response attributed more to use of ultraviolet in printing than in recording. Practically no gain in signal-to-noise ratio is found by using ultraviolet in either recording or printing.

Photographic Tone Reproduction, Theory and Practice; Loyd A. Jones, *Kodak Research Laboratories, Rochester, N. Y.*

For many years, in fact ever since the early beginnings of photography, many workers in the field have dealt with various phases, both theoretical and practical, of the photographic tone reproduction problem. The word "tone" as used in this connection refers to the brightness and brightness differences existing in the original and in the photographic reproduction thereof. Hurter and Driffeld, who were pioneers in the field of photographic sensitometry, gave some consideration to this problem, and since that time many contributions to the literature of the subject have been made by various contributors. The present paper aims to summarize the work which has been done in this field and to give an account of the present status.

Some of the most recent work done in these laboratories in correlating theoretical and practical aspects of tone reproduction will be discussed in some detail. This work has centered largely upon two subjects: the application of tone reproduction theory to the development of a suitable criterion for expressing the effective camera speeds of negative materials used extensively in the field of amateur photography; and the evaluation of the relative photographic quality of positives in terms of the amount of exposure given in making the negatives from which these positives were made.

As a result of these studies, direct practical evidence has been obtained which verifies quite satisfactorily the theoretical conclusions previously reached to the effect that the gradient characteristics of both negative and positive sensitometric curves are of utmost importance in the determination of effective camera speeds and photographic positive quality as evaluated directly in terms of perceptual factors.

Tone Reproduction in Television; I. G. Maloff, *RCA Manufacturing Co., Inc., Camden, N. J.*

The purpose of television is to produce moving pictures of original scenes in homes, auditoriums, and theaters. From the standpoint of the requirements of pictorial tone reproduction, television is closely related to motion pictures. However, the technic of tone reproduction in television is vastly different from that in motion pictures. The degree of perfection of pictorial tone reproduction of present-day television is, in some respects, not as high as that obtainable with 35-mm motion pictures. On the other hand, the medium of television is the electrical signal, which is a great deal more flexible than photographic emulsions and permits effects unobtainable with the latter.

The paper treats pictorial tone reproduction in television in detail. Means of obtaining desired range, contrast, perspective, and intensity, with adequate resolution, adequate illusion of motion and freedom from flicker, are discussed. Limitations and flexibility of pictorial tone reproduction in television are described in comparison with older methods of pictorial reproduction, and typical

tone reproduction characteristics of the complete television system as well as its essential components are given.

Direct 16-Mm Production; Lloyd Thompson, *The Calvin Company*, Kansas City, Mo.

There are so many reasons why 16-mm film can and should be used that the industrial and educational user is using more and more of it. The production of 16-mm sound pictures by the direct method has been making progress. Today there are a number of companies using direct black-and-white and color sound productions in the 16-mm size. Many who are trying to use the method do not understand the proper technic or do not use the best commercial facilities available, which make the process slow in being generally accepted.

Certain advantages and economies are effected by using the direct 16-mm production method which make it desirable for the non-user of sound-films to use this medium for the first time, and for others to use the film more effectively. Complete commercial 16-mm production and laboratory facilities are now available that equal those of the best 35-mm industrial producers. The problem of making wipes, fades, dissolves, and other tricks in the laboratory has been solved for direct 16-mm production. Re-recording facilities for blending sound from several sources are available, making it possible to achieve truly professional results by the direct method. A few examples of direct 16-mm productions are given.

Commercial Motion Picture Production with 16-Mm Equipment; John A. Maurer, *The Berndt-Maurer Corp.*, New York, N. Y.

Production of commercial sound motion pictures directly in the 16-mm size has increased rapidly during the past few years. Particularly in the production of those types of industrial films which are photographed in the field or factory rather than in the studio, the well known advantages of relative simplicity, portability, and freedom from fire risk in 16-mm equipment lead to economies that have frequently been decisive in making possible new applications of films.

This paper surveys broadly the equipment, films, and services that are available for 16-mm production, and presents a critical evaluation of the methods that are in use.

Copies of 16-mm films are being produced at the present time by reversal duplication from reversal originals, by making prints from reversal originals by means of an intermediate negative on fine-grain stock, by the direct negative-positive procedure, and by Kodachrome duplication. Prints produced by each of these processes will be demonstrated.

Professional 16-Mm Recording Equipment; D. Canady, *Canady Sound Appliance Co.*, Cleveland, Ohio.

Details and description of 16-mm sound recording equipment for professional use is given, including:

- (1) A 16-mm recorder employing a high-quality optical system and glow-lamp.
- (2) Sound-track optical-reduction printer, permitting 16-mm variable-density sound-track being made from either 35-mm variable-density or variable-area recorded track.

(3) Noise-reduction equipment, for use in connection with glow-lamps or the new high-pressure quartz mercury lamp.

Sixteen-Mm Equipment and Practice in Commercial Film Production; J. F. Clemenger and F. C. Wood, Jr., *Sound Master, Inc.*, New York, N. Y.

Today's commercial film is designed to accomplish a specific purpose and is therefore particularly directed to a specific audience. Prior to the introduction of the 16-mm sound projector, commercial sound-films could for the most part be shown only to theatrical entertainment audiences.

The immediate acceptance and rapid growth in use of 16-mm sound projection equipment for the first time made it possible for the commercial film producer to select the audience most useful to him.

At first practically all commercial 16-mm sound-films were made on 35-mm equipment and subsequently optically reduced to obtain 16-mm prints. It soon became obvious that it would be desirable to produce these films in the same medium in which they were to be shown. Among the advantages to be gained by such procedure were the absence of fire risk and consequent freedom from legal restrictions, the compactness and portability of equipment, lower raw-stock and print costs, and greater flexibility.

The RCA Portable Television Pick-Up Equipment; G. L. Beers, *RCA Manufacturing Co.*, Camden, N. J.; O. H. Schade, *RCA Radiotron Corp.*, Harrison, N. J.; and R. E. Shelby, *National Broadcasting Co.*, New York, N. Y.

Spot news, athletic events, parades, *etc.*, form an important source of television program material. Portable pick-up equipment suitable for televising such events has recently been developed. The equipment includes a small Iconoscope camera, camera auxiliary, camera control and synchronizing generator units, and a 325-megacycle relay transmitter and receiver. Most of the units are about the size of a large suitcase and weigh between 40 and 70 pounds. Each of the units is described and some of the practical applications of the equipment are indicated.

Quality in Television Pictures; P. C. Goldmark and J. N. Dyer, *Television Engineering Department, Columbia Broadcasting System, Inc.*, New York, N. Y.

Present television standards specify certain factors that determine the appearance of a television picture only to a limited extent. Other factors, however, such as contrast, gradation, brilliance, and the shape of the scanning spot are fully as important and are discussed in the paper.

A photographic method of producing artificial pictures that permits varying several of these factors will be explained. Pictures will be shown that were obtained by this method and approach ideal quality within a given set of standards.

A New Method of Synchronization for Television Systems; T. T. Goldsmith, R. L. Campbell, and S. W. Stanton, *Allen B. DuMont Laboratories, Inc.*, Passaic, N. J.

Line and frame scanning frequencies in an all-electronic television system need not be frozen to a standard giving limited definition performance if the synchronizing system is arranged to allow flexible operation. Automatic operation of re-

ceiver synchronizing circuits at variable line and frame frequencies is made possible with the aid of a new type of synchronizing wave-form. Synchronizing standards which permit both flexible and automatic operation are discussed. Transmitter synchronizing apparatus for flexible synchronizing standards, receiver circuits for both non-automatic and automatic synchronous operation are also discussed, and a "transition" type receiver for operation on both old and new type of synchronizing signals is briefly described.

Advancement in Projection Practice; F. H. Richardson, *Quigley Publishing Co.*, New York, N. Y.

This paper briefly reviews projection practice from the beginning, pointing out the extremely poor conditions confronting projectionists in early days. By means of some twenty stereopticon slides the early projection equipments are illustrated and contrasted with those in use today. The work of some of the outstanding pioneers who had to do with early invention and improvements in projection equipments is described.

Defects in Motion Picture Projection and Their Correction; I. Gordon, Akron, Ohio.

A statement is presented of the various kinds of damage inflicted upon screen images by oil on film. The paper enumerates the sources of this evil, the heavy loss the box-office can suffer as a result of them, the ill effect upon eyes of theater patrons, and suggests means for reducing the evil or possibly eradicating it.

A Personal Safety Factor for Projection Practice; T. P. Hover, Lima, Ohio.

The dangers inherent to the projection of nitrocellulose film are so obvious, and the accidents, when they occur, are so spectacular that practically no attention is given to other hazards in the projection room. This is to be expected in an industry where practically no knowledge concerning the equipment and its operation ever appears to the outside world. Only the joint coöperation of the manufacturer of equipment, the sound supervisor, the theater manager, the projectionists, and intelligent public safety officials can make the profession of projecting motion pictures a safe one. Some of the observations of the author, who is closely associated with safety officials in the State of Ohio, are given in the paper.

Projection Supervision, Its Problems and Its Importance; Harry Rubin, *Paramount Theaters Service Corp.*, New York, N. Y.

The importance of thorough and continuous supervision of projection and sound equipments in the theaters, some of the problems connected therewith in the construction and the maintenance of the theaters; a brief outline of a few of the many details that must be examined and precautions that must be observed in order that the motion picture entertainment may be presented under the most nearly perfect conditions, are described by a Projection Supervisor for a theater chain. Emphasis is placed upon the benefits to be derived through the close coöperation between the supervisor and the projection personnel of the individual theaters and several measures for accomplishing this result are cited.

Products of Combustion of the Carbon Arc; A. C. Downes, *National Carbon Co.*, Cleveland, Ohio.

This paper is a review of work done in the laboratories of National Carbon Company, Inc., the College of Medicine of the University of Nebraska, the School of Public Health of Harvard University, and the Department of Health of the City of Detroit on the products of combustion from carbon arcs used in the motion picture industry. Analyses of the gases coming from various lamps show that, even in the stacks, the only gas occurring in toxic concentration is nitrogen dioxide.

The biological effects of undiluted stack gas from simplified high-intensity arcs upon experimental animals were only those due to the nitrogen dioxide.

The arc-ash fume when administered by intratracheal and subcutaneous routes in rabbits was found to be relatively inert.

Determination of nitrogen dioxide concentrations in poorly ventilated projection rooms failed to show any concentration more than about one-fifth that generally considered as allowable for exposure of several hours duration, and therefore there is little or no hazard in these projection rooms.

Studies of ventilation under controlled conditions show that even with very low rates of both lamp house and room ventilation there is no danger of gases or fumes reaching concentrations which are toxic and that if sufficient ventilation is provided to produce comfortable working conditions there can not be any appreciable concentrations of nitrogen dioxide or arc-ash fumes in the booth.

Rating of Motor-Generator Equipment Used for Direct Current Supply to Projection Arc Lamps; C. C. Dash, *Hertner Electric Co.*, Cleveland, Ohio.

The ratings of electrical equipment in general are based upon the heating and upon the performance.

The projection room duty cycle with the alternate burning of two lamps and a single lamp puts a rather peculiar load upon generating equipment. This affects the temperature rating of the unit. The most important item in connection with the rating is the output characteristic. If designed for heating alone, a generator set would be unsatisfactory.

The paper considers the output characteristics desirable for use with present-day arc lamps and their effect upon the design of the unit. Motor ratings will also be discussed.

Records for the Projectionist; J. R. Prater, Palouse, Wash.

Some portions of the data necessary to good projection room records may be kept to the best advantage on blank forms. Examples are shown of such blanks adapted to (1) an inventory of projection room supplies and spare parts, (2) data on vacuum tubes, (3) exciter lamps, (4) film inspection, and (5) a cue sheet. Noteworthy features are discussed, and suggestions given for adapting these forms to individual projection rooms. Projectionists will find it easier to keep good records on appropriate forms than it is to get by without them.

Mathematical Expression of Developer Behavior; J. R. Alburger, *RCA Manufacturing Company*, Camden, N. J.

Characteristics of developing agents have been unified in a mathematical expression. The use of the analysis of developer behavior afforded by this expression has been helpful in providing a guide toward improving a developer with respect to any given characteristic.

Recording and Reproducing Square Waves; D. Canady, *Canady Sound Appliance Co.*, Cleveland, Ohio.

A brief description of electrical equipment involved in the recording and reproduction of square waves is given.

Direct-coupled amplification is used throughout as conventional amplifier circuits are unsatisfactory when dealing with steep wave-fronts. Toe recording has been found satisfactory as picture requirements are not involved.

Oscillograms and illustrations of mechanical wave-forms used in testing are shown and described. Records showing speech syllables passed through a conventional transformer-coupled system and direct-coupled amplifier are relatively striking and show the usual asymmetries encountered in a-c amplifiers when compared with direct-coupled systems.

Motion Picture Theater Developments; by M. Rettinger, *RCA Manufacturing Company*, Hollywood, Calif.

The first part of the paper is devoted to conveying basic requirements as well as recent developments in the design of motion picture theaters with balconies to provide satisfactory conditions for all the basic considerations of proper motion picture presentation.

The second part is providing similar information pertaining to theaters with balconies. Separate sections are provided for the recommended dimensional and constructional features of balcony depth, soffit, and height; of the theater ceiling, sidewalls, and rear wall; and of the space above the balcony.

Silent Variable Speed Treadmill; J. E. Robbins, *Paramount Pictures, Inc.*, Hollywood, Calif.

Treadmills are a definite necessity to the making of motion pictures for the purpose of obtaining intimate scenes of animated objects or persons working before moving backgrounds. The evolution of this type of equipment dates back to the very beginning of the industry. Due to the fact that noise was of no consequence, these earlier machines were simply and crudely constructed. The type generally used employed the ordinary conveyor-chain principle, utilizing web belts running over series of rollers. Other developments include the revolving disk type, not entirely desirable due to the variation of surface speed in relation to the distance from the center of the circle; the gravity unit motivated by the persons or animals walking or running on them, *etc., etc.* Inasmuch as these were generally operated in front of sky backings or moving panoramas, speed ranges obtainable by gear boxes or belt pulley or chain sprocket changes were adequate. With the advent of sound and a more general use of the transparency or process background the need of smoother, more flexible, silent mills was recognized. The problem was carefully considered by the engineering department of Paramount

Pictures, Inc., and the unit recently developed by them embodies all the previously mentioned requisites and to date has operated satisfactorily under the most trying conditions.

Construction details, speeds, degrees of silence, and other factors are covered in the paper.

Optimum Load Impedance for Feedback Amplifiers; B. F. Miller, *Warner Bros. First National Studios*, Burbank, Calif.

The apparent plate-resistance of vacuum-tubes employed in inverse feedback amplifier stages is shown to be a function of the degree of feedback employed. Equations for predicting the optimum value of amplifier load impedance for maximum undistorted power output are derived, and the necessity for properly building out the amplifier load circuit is demonstrated. A basic circuit, employing a combination of two feedback elements is indicated, which permits securing the maximum undistorted power output from an amplifier stage while maintaining proper impedance relationships between amplifier and load circuits without the use of building out resistors.

A Modern Studio Laboratory; G. M. Best and F. R. Gage, *Warner Bros. First National Studios*, Burbank, Calif.

A description of the new laboratory erected by Warner Bros. at Burbank, Calif, in 1938. No general release work is required of this laboratory, and the generous space provided is devoted exclusively to the developing and printing of the dailies, storage and handling of the negative, and the latest in air-conditioning and dust-removing equipment. Advantage has been taken of the recent developments in rust-resisting and acid-proof metals, especially in the construction of the developing machine tanks. The description includes the method of operation through the dailies, negative cutting, printing, chemical mixing, silver recovery, and other essential processes.

Audience Noise as a Limitation to the Permissible Volume Range of Dialog in Sound Motion Pictures; W. A. Mueller, *Warner Bros. First National Studios*, Burbank, Calif.

A series of noise measurements were made in theaters to determine the cause of low intelligibility of dialog recordings of wide volume range. Audience noise level was found to be a serious restriction, because it averages 8 db louder than film noise level and reduces the useful volume range by that amount. Audience noise is an extremely variable factor, as measurements made in the same theater showed it to be as low as the film noise in one instance and later to rise 14 db above this value. To secure good intelligibility, the volume range of the dialog must be compressed so that the softest-spoken words never are so low in level as to be seriously masked by audience noise.

Color Theories and the Intersociety Color Council; H. P. Gage, *Corning Glass Company*, Corning, N. Y.

Thanks to intensified study of color by scientists of the National Bureau of

Standards, of the Agricultural Marketing Service of the U. S. Department of Agriculture, of the committees of the American Association of Railways, glass manufacturers, dye manufacturers, paint and ink manufacturers, the American Pharmaceutical Association, and photographic manufacturers, and the stimulation of the motion picture industry, the theories of color have been put in shape and tied together with extensive data on the color vision of many observers so that a workable engineering evaluation of colors, a scientific system of naming them, and a practical means of producing them to exact specification is now available and is ripe for presentation not only to learned societies but to the general public.

The phenomena and theory of the production of color in photographs both still and motion pictures have frequently been presented to this Society, and some phases will be rapidly reviewed in a demonstration of the spectral characteristics of color.

Colored lights are subject to spectrophotometric measurement and by means of the I.C.I. (International Commission on Illumination) data can be interpreted in terms of luminosity and the x and y coordinates (or maps defining chromaticity).

In these terms are being defined all standard Atlases of Color such as the Maertz & Paul Dictionary of Color, the Munsell Book of Color, and, it is hoped, the next standard set of colors of the Color Card Association used by all manufacturers of clothing and other things in which standardization of manufacture in spite of rapidly changing styles is an economic necessity.

The next edition of the National Formulary, sponsored by the American Pharmaceutical Association, will use this system of color names to describe the normal appearance of all drugs and chemicals.

A shorthand method of describing the spectrophotometric analysis of color filters for theater spot and floodlights in the form of a seven-digit number has been devised for commercial specification of this material.

These activities of numerous separate individuals and members of different technical societies have been coordinated and freely discussed by the delegates and individual members of the Intersociety Color Council so that all phases of the situation have been discussed.

The Intersociety Color Council is made up of 74 delegates appointed by 11 member societies, and by 67 individual members. It functions as a joint committee on color of the member societies favored with the advice of the individual members. The Council issues News Letters in mimeograph form to its members. They contain information of progress in color work, notices of important color publications, the activities of the Color Council and notices of its planned meetings. It is not intended as a competing journal but with the minutes of the meetings serves as a basis for reports by the delegates to the member societies which can be published in their Journals. The Council sponsors meetings with the member societies on the subject of color. These papers are published in the journals of the societies. Such joint meetings have been held with the Optical Society of America, the Technical Association of the Pulp & Paper Industry (T.A.P.P.I.), the American Psychological Association, and a joint technical session on color will be held at the annual convention of the Illuminating Engineering Society this fall.

The Cyclex System of Motion Picture Projection; C. S. Ashcraft, *Ashcraft Mfg. Corp.*, Long Island City, N. Y.

Cyclex is a new method of light projection, particularly adapted to the projection of motion pictures. It is based on a method of coördinating light impulses, whereby alternating current may be used for the production of an electric arc and the light therefrom projected through a rotating shutter upon a screen, with a total absence of the periodic visual beat which has heretofore characterized alternating-current projection arcs.

Simultaneously with the development of the non-pulsating alternating-current projection system, has been the development of a distinctly new type of alternating-current arc, wherein the characteristics of the arc itself have been used to the best advantage. Heretofore the method of operating alternating-current arcs has not been conducive to obtaining the highest efficiency and economy. The new *Cyclex* arc, however, has resulted in a light-source producing a far greater screen brilliancy together with a greatly reduced power input and consequent carbon consumption.

The practical application of the combination necessitated the development of a radically new type of power conversion equipment, particularly adapted to the operation of the new arc. This equipment must have such characteristics that coördinated light impulses may be obtained with the maximum of electrical and mechanical efficiency, simplicity, and flexibility.

The purpose of the present paper is (a) to present the basic theory of the system, (b) explain the characteristics of the *Cyclex* arc, together with the quality of the light produced, and (c) describe the apparatus employed for flexible frequency conversion and method of polyphase current transformation for the arc supply.

Television Pick-Up of the Pasadena Rose Tournament Parade, January 1, 1940; H. R. Lubcke, *Don Lee Broadcasting System*, Los Angeles, Calif.

The first television pick-up of the Pasadena Rose Tournament Parade was made on New Year's Day, 1940. This was accomplished with the "suitcase" type portable television equipment and beam transmitter *W6XDU* of the Don Lee Broadcasting System.

Two television cameras were used to give long-shot and close-up views of the floats; the cameras being arranged to give instantaneous switching of scene. The distance from Pasadena to the Don Lee Building, site of the home transmitter *W6XAO*, is nine miles and the line of sight was interrupted by two hills and buildings. Since the portable transmitter operates on a wavelength of less than one meter, much effort was therefore directed toward erecting high and efficient antennas at the transmitter and receiver.

Diathermy machines, as used by the medical profession, were found to cause interference even on the beam transmitter frequency of 324 megacycles, indicating the need for proper shielding of such devices.

The sound portion of the broadcast was sent over the nationwide Mutual Network. Camera work and aural description were adequately synchronized. Although rain fell during the parade and the morning was darkly overcast, written statements of reception from *W6XAO* lookers up to 15 miles away reported clear images, enabling them to read the names on the floats and discern other items of detail.

Speed Up Your Lens System; W. C. Miller, *Paramount Pictures, Inc.*, Hollywood, Calif.

The tendency of bare glass surfaces to reflect light has always presented a serious problem in optics. New discoveries in the field of physics have resulted in methods of reducing these light reflections. One of these methods has proved practicable for general use in optical equipment. The reduction of reflections in treated systems has been so great that ghosts and flares are rarely encountered. The light no longer reflected by the glass surfaces is transmitted by the optical systems, increasing their efficiency. Camera lenses treated with the new process show an increase in speed of nearly a full stop. New applications of the process are being found almost daily.

The Theory of Three-Color Reproduction in Motion Picture Photography; J. B. Engl, New York, N. Y.

The theory of Three-Color reproduction of Hardy-Wurzburg gives the necessary conditions which have to be fulfilled in order to get a truthful reproduction of color. It is applied to the production of colored moving films. The possibilities of color corrections in film practice are discussed. Considerations of cost and of technical difficulties seem to lead to the conclusion that the most practical is the known method of color correction in the recording process by an artificial distortion of the color values of the subject.

The theory allows an approximate computation of the necessary amounts of distortions. Truthful color rendering to a certain extent can be obtained in a predetermined way. The necessity of a systematic study of artificial color distortion is emphasized.

A Precision Integrating-Sphere Densitometer; J. G. Frayne and G. R. Crane, *Electrical Research Products, Inc.*, Hollywood, Calif.

A densitometer employing an integrating sphere associated with a stable high gain amplifier is described. Densities up to 3.0 are read directly on a multiple scale logarithmic meter. Visual diffuse operation is attained by simulating average eye characteristic by inserting appropriate filters in optical path.

Filtering Factors of the Magnetic Drive; R. O. Drew and E. W. Kellogg, *RCA Manufacturing Co.*, Camden, N. J.

A laboratory model of magnetic drive film phonograph was modified so that speed fluctuations of large and measurable magnitude and of frequencies ranging from $1/2$ to 7 cycles could be introduced either into the sprocket rotation or the magnet rotation. The resulting speed variations at the drum were determined by means of a "wowmeter." The large ratios of flutter reduction indicated by these measurements show in part why the magnetic drive gives unsurpassed film motion.

SOCIETY ANNOUNCEMENTS

STANDARDS COMMITTEE

At a meeting held at the office of the Society on March 13th a collection of all the standards of the SMPE and the Academy Research Council, prepared for submittal to the ASA, was reviewed. Most of the projects had been approved by both organizations, but several of the standards, including that of the release-print sound-track dimensions, are still under consideration.

In addition to all these items, which include all the standards published in the March, 1938, issue of the JOURNAL, arrangements were made for a revision of the glossary and a study of blooming patches.

The next meeting of the Committee will be held some time in May.

TELEVISION COMMITTEE

On March 20th a meeting of the Television Committee was held at the office of the Society, at which time the agenda for the present season was established and the Sub-Committees organized. A Sub-Committee was delegated to complete the work on the television glossary which had been started during the previous year and another Sub-Committee to finish the work on the television bibliography.

The scope of the Committee's work was enlarged to include reproducing characteristics of viewing devices, electrical and operating characteristics of pick-up devices, studio lighting and camera technic, characteristics of film-scanning apparatus, and the ultimate recommendations for standardization deriving from these studies.

On March 29th the Committee held a meeting at the CBS Television Studio in New York for a demonstration of the test-films developed during the past few months for use on the iconoscope and dissector channels.

The next meeting of the Committee is scheduled for May 3rd.

PROJECTION PRACTICE

The Sub-Committee on Projection Practice held two meetings, on February 29th and March 14th, at the Paramount Building, New York. The activities of the Working Committees were discussed and plans were made for continuing the work on tolerances and on projection screen brightness.

Arrangements have been made for a presentation on the subject of projection room fire regulations at the meeting of the Fire Marshals at Atlantic City, May 4th, under the auspices of the National Fire Protection Association. The Working Committee on the Projection Room Plans has begun a revision of the plans published in 1938 in order to bring them up to date, and the Power Survey Working Committee is now preparing a report from the data derived from the thousand or more questionnaires sent out during the past season to the theaters of the country.

ATLANTIC COAST SECTION

At a meeting held at RCA Photophone Studios, New York, on March 13th, Dr. C. H. Cartwright of Massachusetts Institute of Technology, presented a lecture on the new reflection-reducing coated lenses. The lecture was followed by the projection of two identical films from two projectors adjusted identically, one projector employing a regular uncoated lens and the other projector employing a lens identical in all respects except that its surfaces were coated.

Half the aperture of each machine was masked so that the two halves of the pictures from the two machines matched up on the screen. Definite comparison of the improvement in light transmission was thereby made possible.

The meeting was very well attended, nearly 300 persons being present, and an interesting discussion followed the presentation.

MID-WEST-SECTION

At a meeting held at the Western Society of Engineers in Chicago on February 27th, Mr. W. C. Kalb of the National Carbon Company presented a talk on the subject of "Projection Light—Then and Now." The paper described in detail the evolution of the electric arc as applied to the projection of motion pictures, beginning with the vertical arc using incandescent carbons, to the present super-high-intensity and the Suprex horizontal arcs utilizing the highly developed gaseous cored-type of carbon.

The meeting was very well attended and a lively discussion followed the presentation.

PACIFIC COAST SECTION

On March 11th a dinner-meeting of the Section was held at the Hollywood Athletic Club, at which time two presentations were given:

Mr. S. Charles Lee, theater architect, presented a talk on the engineering features involved in the design of motion picture theaters, and Mr. E. H. Marks of the National Theater Supply Company discussed the commercial aspects of screen illumination.

JOURNAL

OF THE SOCIETY OF

MOTION PICTURE ENGINEERS

Volume XXXIV

May, 1940

CONTENTS

	<i>Page</i>
Progress in the Motion Picture Industry.....	455
Chemical Analysis of Photographic Developers and Fixing Baths.....R. B. ATKINSON AND V. C. SHANER	485
Motion Picture Theater Developments.....M. RETTINGER	524
New Motion Picture Apparatus The Resonoscope.....S. K. WOLF AND L. B. HOLMES	534
Current Literature.....	539
Highlights of the Atlantic City Convention.....	541
Program of the Atlantic City Convention.....	545
Society Announcements.....	548

JOURNAL

OF THE SOCIETY OF

MOTION PICTURE ENGINEERS

SYLVAN HARRIS, EDITOR

Board of Editors

J. I. CRABTREE, *Chairman*

A. N. GOLDSMITH

A. C. HARDY

T. E. SHEA

J. G. FRAYNE

L. A. JONES

G. E. MATTHEWS

E. W. KELLOGG

Subscription to non-members, \$8.00 per annum; to members, \$5.00 per annum, included in their annual membership dues; single copies, \$1.00. A discount on subscription or single copies of 15 per cent is allowed to accredited agencies. Order from the Society of Motion Picture Engineers, Inc., 20th and Northampton Sts., Easton, Pa., or Hotel Pennsylvania, New York, N. Y.

Published monthly at Easton, Pa., by the Society of Motion Picture Engineers.

Publication Office, 20th & Northampton Sts., Easton, Pa.

General and Editorial Office, Hotel Pennsylvania, New York, N. Y.

West Coast Office, Suite 226, Equitable Bldg., Hollywood, Calif.

Entered as second class matter January 15, 1930, at the Post Office at Easton, Pa., under the Act of March 3, 1879. Copyrighted, 1940, by the Society of Motion Picture Engineers, Inc.

Papers appearing in this Journal may be reprinted, abstracted, or abridged provided credit is given to the Journal of the Society of Motion Picture Engineers and to the author, or authors, of the papers in question. Exact reference as to the volume, number, and page of the Journal must be given. The Society is not responsible for statements made by authors.

OFFICERS OF THE SOCIETY

- * *President*: E. A. WILLIFORD, 30 East 42nd St., New York, N. Y.
- * *Past-President*: S. K. WOLF, RKO Building, New York, N. Y.
- * *Executive Vice-President*: N. LEVINSON, Burbank, Calif.
- ** *Engineering Vice-President*: D. E. HYNDMAN, 350 Madison Ave., New York, N. Y.
- * *Editorial Vice-President*: J. I. CRABTREE, Kodak Park, Rochester, N. Y.
- ** *Financial Vice-President*: A. S. DICKINSON, 28 W. 44th St., New York, N. Y.
- * *Convention Vice-President*: W. C. KUNZMANN, Box 6087, Cleveland, Ohio.
- * *Secretary*: J. FRANK, JR., 356 W. 44th St., New York, N. Y.
- * *Treasurer*: R. O. STROCK, 35-11 35th St., Astoria, Long Island, N. Y.

GOVERNORS

- * M. C. BATSEL, Front and Market Sts., Camden, N. J.
- * J. A. DUBRAY, 1801 Larchmont Ave., Chicago, Ill.
- ** A. N. GOLDSMITH, 580 Fifth Ave., New York, N. Y.
- ** H. GRIFFIN, 90 Gold St., New York, N. Y.
- * P. J. LARSEN, 29 S. Munn Ave., East Orange, N. J.
- * L. L. RYDER, 5451 Marathon St., Hollywood, Calif.
- ** A. C. HARDY, Massachusetts Institute of Technology, Cambridge, Mass.
- * H. G. TASKER, 14065 Valley Vista Blvd., Van Nuys, Calif.

* Term expires December 31, 1940.

** Term expires December 31, 1941.

PROGRESS IN MOTION PICTURE INDUSTRY *

REPORT OF THE PROGRESS COMMITTEE FOR 1939

Summary.—This report of the Progress Committee covers the year 1939. The advances in the cinematographic art are classified as follows: (I) Cinematography: (A) Professional, (B) Substandard; (II) Sound Recording; (III) Sound and Picture Reproduction; (IV) Television; (V) Publications and New Books.

In the field of cinematography there has been little to report this year in the way of new emulsions. The only item of outstanding interest is the introduction of coated camera lenses to reduce surface reflections. This improvement promises to have revolutionary effects in this field. In the amateur field many high-speed emulsions have been made available for the first time to the amateur and there has been considerable improvement in projection equipment in both 16-mm and 8-mm fields. The excellent pictorial and sound quality now obtainable by the 16-mm medium is making it possible to photograph and record directly on 16-mm film, thereby opening up a vast field for the 16-mm technic.

In the field of sound recording one of the most significant advances of the year has been the use of fine-grain films in variable-density recording and printing. The use of these films brings about a marked reduction in ground-noise as well as improving the quality of the reproduced sound.

In the field of television one of the most notable advances has been the introduction of mercury arcs to provide cool lighting on the television stage.

Current hostilities in Europe and in the Orient have disturbed conditions there so that the Committee has no reports from its correspondents abroad.

The Committee wishes to thank the following companies for supplying material and photographs for the report: Electrical Research Products, Inc.; Eastman Kodak Company; Ampro Corp.; General

* Presented at the 1940 Spring Meeting at Atlantic City, N. J.; received April 15, 1940.

Electric Co.; General Radio Corp.; RCA Victor Corp.; and 20th Century-Fox Studio.

J. G. FRAYNE, *Chairman*

F. G. ALBIN	R. E. FARNHAM
L. E. CLARK	J. L. FORREST
G. L. DIMMICK	F. L. HOPPER
R. J. ENGLER	G. E. MATTHEWS
E. W. ENGSTROM	V. E. MILLER

SUBJECT CLASSIFICATION

(I) **Cinematography**

(A) *Professional*

- (1) Emulsions
- (2) Cameras and Accessories
- (3) Lenses
- (4) Studio Lighting
- (5) Color

(B) *Substandard*

- (1) Films
- (2) Cameras and Accessories
- (3) Projectors and Accessories

(II) **Sound Recording**

- (1) General
- (2) Equipment
- (3) Recording Methods

(III) **Sound and Picture Reproduction**

(IV) **Television**

- (1) General
- (2) Lighting

(V) **Publications and New Books**

(I) **CINEMATOGRAPHY**

(A) *Professional*

Last year the Progress Report called attention to the improvement of panchromatic emulsions as the outstanding advance of the year. This year there is nothing notable to report in this field, and this is in marked contrast to the advances made in emulsions for sound recording and printing purposes which are discussed later in this report.

(1) *Emulsions*.—An interesting paper by Schilling¹ discussed the various films now supplied by Agfa to the German market, including Superpan, Ultrarapid, Pankine *H*, and Finopan. Data on developing properties, speed, color-sensitivity, and graininess are included.

A faster, finer-grained panchromatic negative film known as Superior-2 (Type 126) was announced by Dupont in December. It was claimed to have about double the speed of Superior-1 and to retain the wide latitude and shadow detail rendering characteristics of the earlier product.

The supply of raw materials for photographic manufacturing operations in this country was not cut off at the outbreak of hostilities in Europe in September as it had been in 1914. During the quarter century that had elapsed, sources of supply of several materials, such as gelatin, optical glass, sensitizing dyes, and certain developing agents, were built up in the United States.

Motion picture film and the properties of its support from the standpoint of safety were discussed by Sulzer,² who dealt with the control of fire hazard in the production, distribution, and use of cellulose nitrate film. His report also treated the characteristics of cellulose acetate film in relation to this problem. Reports from abroad indicated that a gradual change-over to acetate film stock for 35-mm film appeared to be under way in Germany and France.³

A paper (in Russian) by Pakshver and Mankash gave data for calculating the rate of evaporation of the solvent from cellulose ester dopes in film-coating machines. The simplest case is considered of the evaporation of acetone in still air at 50°C from a solution containing 27.5 per cent cellulose acetate without a plasticizer.⁴

A series of experiments by Charriou and Valette⁵ on hypersensitization of emulsions showed that the effect of a given treatment tends to increase with increasing wavelength. The total sensitivity of an infrared-sensitive emulsion was found to reach a value seven times the initial sensitivity. Several interesting theoretical papers by Trivelli and Smith dealt with a number of problems relating to emulsions such as sensitometric and size-frequency characteristics, H&D speed *versus* average grain size, effect of grain size on finishing, development in relation to coating thickness, and resolving power and structure.⁶

Of historical interest is the fact that the year 1939 marked the fiftieth anniversary of the introduction of roll film by George Eastman and the sale of the first film by him to Thomas Edison with which the latter and W. K. L. Dickson prepared a short length of the first motion pictures. These were viewed with the aid of a peep-show device called the "Kinetoscope." The year also represented the hundredth anniversary of the first public announcement and demonstration of the Daguerreotype process.

(2) *Cameras and Accessories.*—The 20th Century-Fox camera described in last year's report has been greatly improved and is now in constant use on production. The relation in size between this silent camera and the present blimp camera is illustrated in Fig. 1, the new camera being shown on the right.

The new mobile camera crane devised by John Arnold and his co-workers at MGM Studios combines all the features in one assembly necessary to three-dimensional movements of a camera. By the addi-



FIG. 1. Comparison of blimp camera (*left*) and 20th Century-Fox silent camera (*right*).

tion of a "fifth wheel," the device may be turned in less than its own length. Mounted on this dolly, a central upright cylindrical post carries the counterbalanced arm that may be raised and lowered by a motor-driven jack or screw, permitting its use in very low-ceilinged sets. This arm carries the camera assembly at one end and a handwheel at the opposite end; this handwheel varies the enclosed counterbalances that will balance a full 1000 pounds at the camera. This arm, with a radius of eight feet, swings through 360 degrees, or a complete circle.

This is the only camera assembly that will enable the operator to shoot in every direction with equal facility within an area limited only by the length of the arm in transverse directions; this movement is unlimited in the direction of dolly travel.

(3) *Lenses.*—One of the outstanding advances this past year has been the introduction of "coated" lenses in the camera to reduce reflection at the glass-air surfaces. The technics used by the two outstanding experimenters in this field, namely, C. H. Cartwright of



FIG. 2. Fresnel lens "baby" spotlight.

Massachusetts Institute of Technology and John Strong of California Institute of Technology, are essentially similar and consist of depositing a transparent fluoride layer on the glass. For optimum performance this layer should be $\frac{1}{4}$ the wavelength of light. A set of coated lenses has been in use at Paramount, and it is claimed that an $f/2.3$ lens, when so treated, becomes equivalent to an $f/1.6$, meanwhile retaining the depth of field, and the definition of the $f/2.3$. Another way of stating this would be that the loss of light in an Astro "Pan-Tachar" lens, which is normally about 41 per cent, becomes negligible when such a lens is treated to reduce surface reflections. While the deposited film on each lens surface is only four millionths of an inch

in thickness, the lens may be handled and even washed without removing this film. Its iridescent magenta sheen, it is believed, will not interfere with color photography, as tests indicate no interference with either transmission or color correction. Undoubtedly, this improvement in the optical world, when fully perfected, will prove the outstanding and most progressive step of the year, presaging future advantages of inestimable value to an industry so wholly dependent on "little pieces of glass."

(4) *Studio Lighting*.—The use of fluorescent lamps for motion picture photography is discussed in detail in a paper by Inman and Robinson,⁷ given before the Society at its 1939 Spring Meeting in Hollywood. These lamps have continued to be used in increasing numbers, particularly for close-ups in black and white. The daylight lamp works particularly well in Technicolor photography.



FIG. 3. No. 5 photoflash lamp
(Courtesy General Electric Co.).

New "Tulamp" auxiliaries operating one lamp at leading power factor, and the other at lagging power factor, minimize stroboscopic effects and allow alternating current operation with greater efficiency.

A small Fresnel lens spot ("Baby Keglight") (Fig. 2), using 500 and 750-watt lamps, has come into general use, made possible by more sensitive film. The lamps are available in 50-hour life (*MP* type); 3380°K (with special filter) for Technicolor photography, and 3200°K for use with Eastman's Type *B* Kodachrome film.

A still smaller edition of this spot with Fresnel lens, using 150 and 200-watt lamps, introduced by a number of manufacturers, has become quite popular, both in motion picture photography and amateur still and movie photography.

Of particular interest to motion picture still photographers and, no doubt, of general interest to others in the industry are the new Daylight Blue Photoflash Lamp No. 21*B* and Photoflash Lamp No. 5.

The first is a regular No. 21 foil-filled photoflash lamp with a blue lacquer to act as a light filter. The resulting light output gives very satisfactory colors with the regular type Kodachrome. The No. 5 photoflash lamp introduced the past year by the Mazda lamp manufacturers is unique because of its small size combined with a relatively great light output (Fig. 3). A large number of these lamps can be carried in one's coat pocket. When used with an efficient reflector, this little lamp will do the work of lamps several times its size. Its aluminum wire filling gives a fairly broad flash characteristic suitable for synchronization.

(5) *Color*.—In the field of color processes, Technicolor continued to dominate all other commercial production methods using 35-mm film. More pictures were made by this process than in any year heretofore. For example, nine Technicolor feature productions were in progress during the month of July. One of these, *Gulliver's Travels*, produced by Fleisher, represented the second feature-length cartoon ever made. The longest color motion picture ever produced, *Gone with the Wind*, was commented on very favorably for the beauty of its artistry and the quality of the color photography.

The Telco process for 35-mm film was stated to utilize bipack negatives from which black-and-white prints are made on both sides of duplitized positive film. The positive image is swollen during processing in proportion to the exposure gradation, and for that emulsion printed from the panchromatic negative, a red dye is introduced into the relief to fill the unswollen parts. After buffing and reswelling, a yellow dyed gelatin layer is applied. The process is repeated on the opposite side of the ortho negative where blue and green-dyed layers are used.⁸

Expansion of facilities was announced for two bipack processes, Cinemacolor and Magnacolor. A new plant with a stated capacity of one million feet of two-color prints each week was opened by Cinecolor in Burbank, Calif., in March, 1939. Interest was developed in the monopack triple emulsion processes, Kodachrome and Agfacolor, although to date these have been used only for still photography.

(B) *Substandard*

Present trends in the substandard motion picture field make it possible now to classify this phase of the industry into two groups: the 16-mm or semiprofessional, and the strictly amateur 8-mm group.

Continual improvements in film quality, combined with better and

more powerful projection equipment, now make it possible to exhibit 16-mm productions successfully before large audiences. This, together with the generally lower production cost of 16-mm productions, has been instrumental in supplanting 35-mm film in many fields in which it, before the advent of these improvements in 16-mm film, found exclusive use. Sixteen-mm equipment is, in general, smaller and more flexible than 35-mm equipment. During the last year manufacturers, awakening to the possibilities offered by this recording medium, have striven to develop 16-mm films, cameras, projectors, and accessories which would provide the same facilities that heretofore have been available only to the professional user of 35-mm film. In this they have been eminently successful, and today users of 16-mm films have at their disposal equipment capable of delivering results favorably comparable to 35-mm productions.

The necessity for making the original recordings on 35-mm film with subsequent reduction to the 16-mm width no longer exists. During the last year numerous complete advertising productions were recorded directly on 16-mm film. Some were recorded by the negative-positive technic, while others, taking advantage of the improved quality of reversible films, made use of the somewhat longer method of making the original on reversible film and the prints on positive film from a dupe negative.

Manufacturers of both 8-mm and 16-mm equipment have been forced, because of the unsettled conditions abroad, to confine their activities to the domestic market. This has severely curtailed production on much of the better projection equipment which, up to the time of the war abroad, was being exported in large quantities. These products were finding a ready market in professional use where substandard films—particularly in the 16-mm width—are used for entertainment purposes in theaters.

The amateur and public in general seem to have become so accustomed to having sound with motion pictures that, with the exception of strictly home exhibitions, any motion picture film shown publicly is regarded as incomplete if it does not have at least a suitable musical accompaniment. For many otherwise satisfactory educational and entertaining pictures, a sound-track on the film is not feasible because of either the technical difficulties or the cost, or a combination of both. Not to be handicapped by these difficulties, these exhibitors have turned to the use of records. The libraries of the various record producers offer inexhaustible sound material of excellent quality

which can be suitably selected to provide background music for almost any type of picture. This can not be considered as a substitute for sound-on-film as far as commentary is concerned; however, when one considers that at least three-fourths of the time of the average travelogue is consumed with music and that only one-fourth of the actual time is taken up by commentary, it can be seen that the use of records with suitably titled films can, with proper presentation, make a very satisfactory exhibition. The use of recorded music for picture accompaniment has led to the development and introduction of numerous high-grade, compact, portable record-reproducing and record-cutting outfits during the past year. Most of this equipment is sufficiently sturdy and simple for amateur use.

(1) *Films.*—Several new films were introduced during 1939. In the 16-mm field Agfa Ansco introduced Triple-S Superpan Reversible film. This new reversible film has an extremely fast, fine-grained panchromatic emulsion especially suitable for use under difficult light conditions.

Kodak Super-X Panchromatic safety film was introduced by the Eastman Kodak Company. This new film has the same speed as Cine Kodak Super-Sensitive Panchromatic, with slightly higher contrast, less graininess, and better definition. Later a Cine Kodak 8 Super-X Panchromatic Safety Film was made available by the Eastman Kodak Company.

Agfa Panchromatic Reversible film was announced. This film is a medium-speed, fine-grain, completely color-sensitive film having a gradation especially suitable for outdoor use.

Super-X Panchromatic "Reversal" 16-mm sound recording film was offered by the Eastman Kodak Company to provide a film of better sound-recording characteristics combined with better picture quality for simultaneous picture and sound recording purposes.

The Eastman Kodak Company also brought out Safety Super-XX Panchromatic Negative film for workers desiring a 16-mm negative medium.

Agfa Twin 8 Hypan Reversible film was brought out by Agfa Ansco and for the first time provides users of 8-mm equipment with a high-speed, fine-grained reversible film.

The Gevaert Company of America made available a 9.5-mm film for owners of 9.5-mm equipment in the United States. This film is manufactured abroad, but it is processed by Gevaert laboratories in the United States.

(2) *Cameras and Accessories.*—There were no newly designed 16-mm motion picture cameras of American manufacture introduced in 1939. However, a number of the European made cameras were introduced to the American market during this period. Outstanding among these was the Zeiss Movikon. This camera incorporates a coupled range-finder for the 50-mm $f/1.4$ Zeiss Sonnar lens, and has



FIG. 4. Lens extension for Magazine Cine Kodak (Courtesy Eastman Kodak Co.).

interchangeable lenses all working in connection with the coupled range finder. The camera is equipped with variable speeds and hand-crank for either forward or reverse motion.

There were several new cameras introduced abroad during the past year. The Siemens C-2 16-mm camera, made by Siemens-Halske, was introduced in England. This camera is said to be of the preci-

sion magazine type and has four speeds of 8, 16, 24, and 64 frames per second. A feature of the camera is the automatic diaphragm change when changing from one camera speed to another.

A new 8-mm camera was brought out by the Revere Camera Company of Chicago. This new camera is known as the Revere Super 8. It is equipped with an $f/3.5$ Wollensak lens and has a built-in view finder. It has variable speeds of 8, 16, 24, and 32 frames per second. This camera uses single-width 8-mm film.



FIG. 5. Dual-operation Ampro projectors with tri-purpose amplifier.

The Eastman Kodak Company introduced lens extension tubes for the magazine Cine Kodak (Fig. 4). This device is very convenient for obtaining magnified close-ups of such things as flowers.

(3) *Projectors and Accessories.*—Projection equipment has been generally improved during the past year and several new models have been offered. The Kodascope Models *G* and *EE*, introduced last year, have been improved and now provide features for accurately adjusting the relation of the lamp filament to the condensers, provid-

ing better and more even illumination. In addition, these models are now provided with a hinged gate to facilitate threading of the film.

In the 16-mm field, Ampro and Bell & Howell have introduced projectors provided with sufficient illumination for auditorium and theater use. Ampro introduced two new models for dual operation



FIG. 6. Kodascope 8 Model 70 (Courtesy Eastman Kodak Co.).

with a tri-purpose amplifier capable of delivering 55 watts of undistorted power (Fig. 5). The amplifier can be used automatically with either of the twin projectors as well as with a microphone when necessary.

The Filmaster was introduced by Bell & Howell. This projector follows the well established design of Filmo projectors. It is entirely gear-driven and is said to be exceptionally silent. It can be equipped

with line-voltage lamps ranging from 300 to 700 watts. It is equipped with an $f/1.6$ projection lens with a newly designed optical system.

In the 8-mm field, Eastman Kodak and Ampro have introduced new models of projectors. Eastman introduced the Kodascope 8 Model

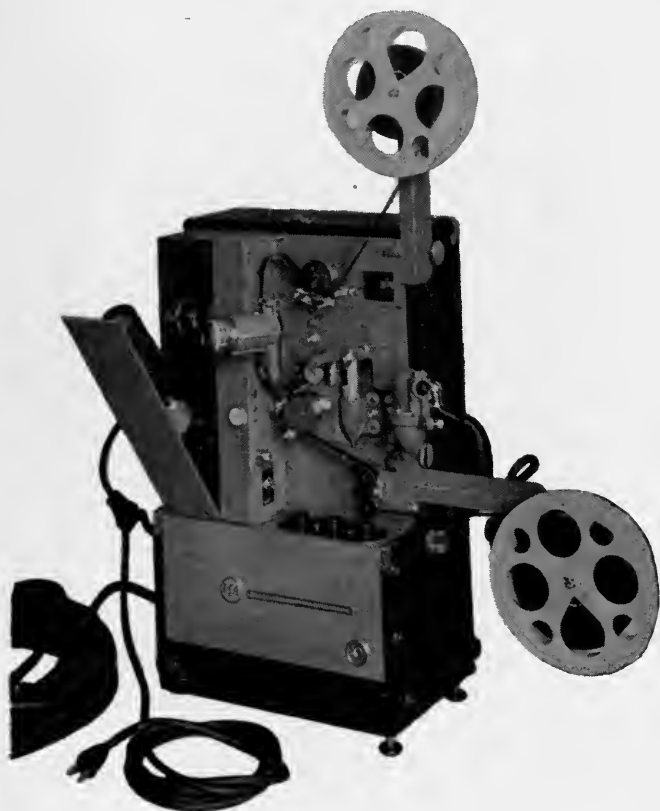

FIG. 7. RCA 16-mm sound projector.

70 (Fig. 6). This newly designed projector has a highly corrected $f/1.6$ projection lens, simplified threading, three-speed control switch, and will accommodate 300, 400, or 500-watt projection lamps.

A new 16-mm sound motion picture projector (*PG-170*) was introduced by RCA. It was designed especially for use by schools, clubs, industrial organizations, *etc.* Among its many desirable features are: simplified threading, separate motor take-up, efficient optical sys-

tems, and good accessibility of all major parts. The amplifier has an output of ten watts at five per cent distortion. The complete equipment is housed in two carrying cases which are easily portable (Fig. 7).

Ampro introduced the Model A-8 8-mm projector. This projector is equipped with an $f/1.6$ projection lens and provides a 500-watt projection lamp. The projector operates on either a-c or d-c. It is provided with sufficient cooling for forward or reverse projection.

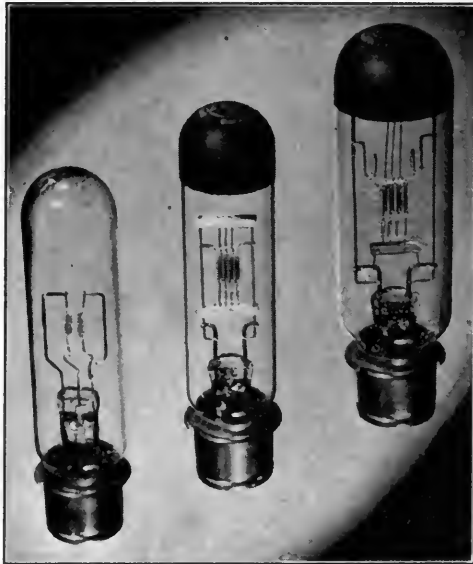

FIG. 8. Black cap projection lamps (Courtesy General Electric Co.).

The Revere Camera Corporation of Chicago introduced a newly designed 8-mm, all gear-driven projector. The projector is of an all-cast construction design provided with a 500-watt line-voltage projection lamp and an $f/1.6$ projection lens.

Manufacturers of equipment abroad are still faced with mechanical complications by the necessity of supplying projection equipment for handling 8-mm, 9.5-mm, or 16-mm film.

All the higher power lamps used for 8 and 16-mm motion picture projection, which include the *T-12* bulb (750 and 1000-watt) and the *T-10* bulb (400 and 500-watt) types are now being supplied with a

black end coating (Fig. 8). This permits simplification of the louvers at the top of the lamp housing and provides better ventilation.

(II) SOUND RECORDING

(1) *General*.—One of the most significant advances of the year in sound recording technics has been the adaptation of fine-grain films to variable-density sound recording. The interest in the use of these films for such work has been due to the possibility that they might offer an appreciable reduction of the background noise existing in present standard stocks. It was felt that a reduction in noise in the film itself was essential to accommodate fully the volume range obtainable in modern sound recording systems. The results of a testing program by several of the West Coast studios and by Electrical Research Products, Inc., were discussed at the 1939 Fall Meeting and published.⁹ Hilliard¹⁰ also reported on the status of this development as carried forward at the MGM Laboratories, and Daily¹¹ described the results obtained by Paramount.

Besides tests on existing fine-grain emulsions, extensive investigation was made on several experimental films, which were developed especially for this purpose. With certain films, the use of an improved type of high-pressure mercury arc offered a satisfactory illuminant. It was also found that the standard tungsten lamp might be used as an exposure source with certain optical systems and under certain development conditions. An improvement in signal-to-noise ratio of at least 6 db was reported for a fine-grain print from a fine-grain negative. Considerable improvement was also noted in overall quality when fine-grain film was used for the original negative, re-recorded print and re-recorded negative, with the final print being made on standard positive film. Improved image definition is also claimed to result, probably due to reduced flare in the emulsion. The results of this development are sufficiently encouraging, according to the Committee Report⁹ that in spite of attendant difficulties, the introduction of the technic on a wide scale into the motion picture industry appears to be inevitable.

There is considerable activity in the studios in adapting fine-grain films to their recording programs. Paramount Pictures, Inc., have employed fine-grain film for all four steps: original, negative, dubbing prints, release negative, and release prints. The use of fine-grain film for release negative at normal gamma complementary to standard release print gamma was made possible by the design of an appropri-

ate developer providing satisfactory density at moderate developing time. Metro-Goldwyn-Mayer Studios have adopted fine-grain film for original negative, exposed by incandescent light (at above normal gamma), and dubbing prints (at complementary gamma). By virtue of the higher negative gamma, satisfactory density is obtained in a standard developer. To obtain sufficient exposure on fine-grain sound negatives, the mercury lamp has been adopted by several studios, including Paramount, Metro-Goldwyn-Mayer, Samuel Goldwyn,



FIG. 9. RCA unidirectional microphone.

and Universal. A forced-draft cooling system has been developed by Paramount, allowing the lamp to be operated at several times the normal rated output. All these above-mentioned studios are regularly using fine-grain film for dubbing prints.

Interest in dynamic testing methods applied to recording systems still continues. Use is made of the intermodulation, or two-frequency method and square-wave generators, or sound-tracks having this type of wave-form recorded upon it. Some measure of transient effects is given by the last two methods, but to date no adequate correlation between measurement and listening has been established. A

large amount of work is required before satisfactory conclusions can be drawn from these methods.

(2) *Equipment.*—An outstanding technical demonstration to the industry was made by Bell Laboratories in the showing of the Vocoder.¹² The device synthesizes speech or music into its components and then remakes it to form the original. Circuit elements are adjust-

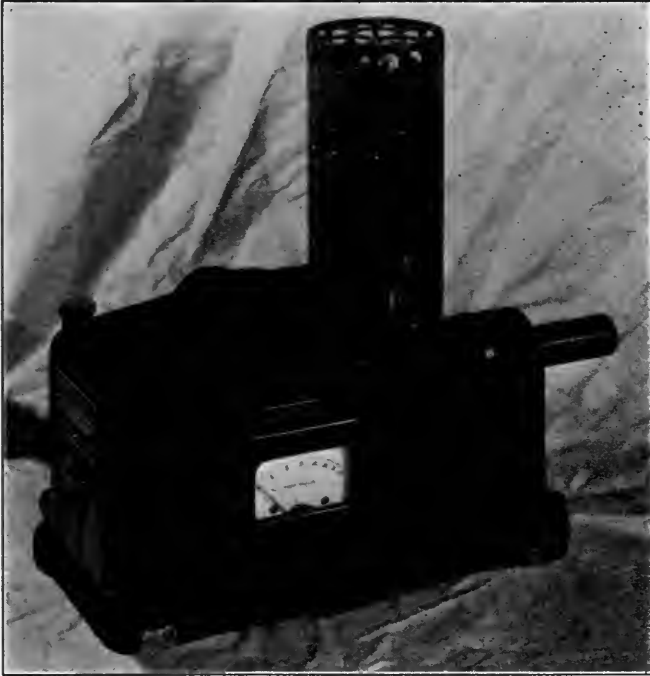

FIG. 10. RCA experimental double-width push-pull variable-area modulator.

able so that certain alterations can be made in the coded material before it is recombined. This allows changes in pitch fundamental and inflection and permits vibrato effects to be added, completely altering the original characteristic of the material. Possible applications to sound recording are: studies of fundamental nature of speech and the way in which its composition is altered by changes in effort; alteration of the characteristics of original speech for improvement of intelligibility; or creation of new types of voices for special or cartoon

effects. Undoubtedly other uses will suggest themselves as further experience is gained with the equipment.

RCA introduced a unidirectional microphone having relatively high sensitivity and a wide frequency range. This unit was developed especially for sound-film recording and is designed for suspension mounting from a boom. The microphone has directional characteristics of the cardoid type and affords a wide angle of pick-up with uniform frequency response. Undesirable sounds such as camera noise

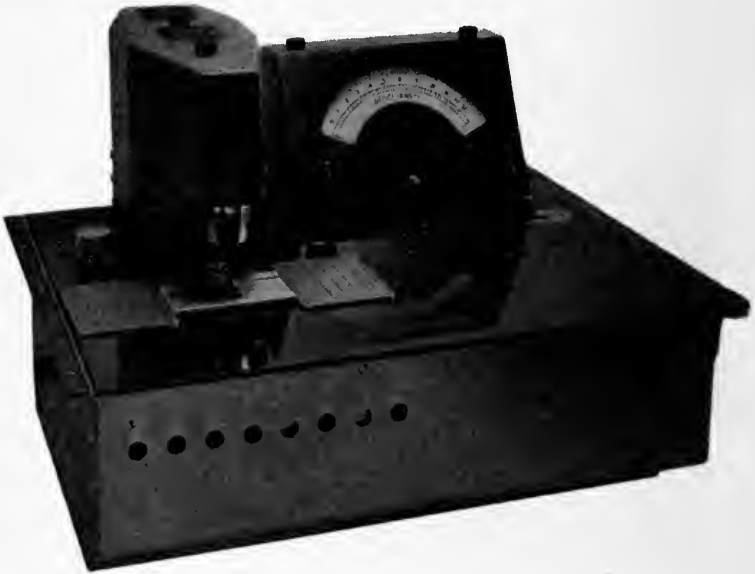

FIG. 11. Precision integrating sphere densitometer (*Courtesy Electrical Research Products Inc.*).

and backstage reflections may be attenuated by the proper use of the directional characteristics. The microphone also tends to minimize the effects due to unfavorable studio acoustic conditions (Fig. 9).

Bell Laboratories have added further versatility to the cardoid microphone by providing switching facilities which give three additional directional patterns falling between the cardoid and bidirectional patterns. These patterns may offer improvement for difficult pick-up conditions.

A push-pull shutter was developed for use with the RCA variable-density recording systems. The shutter has two penumbra vanes

which move apart as the noise-reduction current increases. A fixed vane behind each of these acts as an optical limiter. The actuating motor is of the magnetic type and is similar to the motors employed in variable-area shutters. The standard and push-pull variable-density shutters are interchangeable in the recording optical system without alteration. One of the new shutters has been in use at the 20th Century-Fox Studios for several months.

An experimental recording optical system for making double-width class *A* push-pull sound-tracks was developed by RCA. Adequate exposure for ultraviolet recording is obtained by the use of a high-pressure mercury vapor lamp and a special power supply unit. A corrected spherical-cylindrical objective lens images the slit on the film at 7.5 to 1 reduction in one plane and 3.5 to 1 reduction in the other



FIG. 12. General Radio square-wave generator.

plane. The optical system base, the noise-reduction shutter, and the galvanometer remain unchanged. One complete system was built and is undergoing a series of field tests in Hollywood (Fig. 10).

ERPI has developed a 200-mil push pull variable-width modulator which is capable of exposing standard sound emulsions for ultraviolet recording or fine-grain emulsions for white-light recording with an ordinary tungsten filament lamp. This modulator has been used to record original scorings in some of the Hollywood Studios during the past year.

ERPI has announced a precision integrating sphere densitometer (Fig. 11). The device affords a rapid and accurate means of determining densities by electrical means. Briefly, a light-beam is interrupted by means of a chopper and the modulated light, after passing through the film whose density is to be measured, actuates a photocell which is mounted within a six-inch integrating sphere connected to a

stable amplifier and metering system. Densities are read directly upon a large-scale meter.

General Radio have provided a square-wave generator¹³ for transmission testing purposes. It is used in determining the frequency response, particularly under transient conditions, of amplifiers and other networks. The type 769-A square-wave generator shown in Fig. 12 is a device for converting a sinusoidal timing signal into a square-wave signal. Squaring is accomplished by amplifying a sinusoidal signal and clipping both positive and negative peaks. This partially squared signal is reamplified and clipped a second time. The final signal is then fed through a phase inverter and amplified in a balanced stage.

ERPI has developed an intermodulation meter¹⁴ which is applicable to the two-frequency method of transmission testing. It has already found many applications in sound-picture work for determining optimum conditions for film processing.

The class *B* push-pull variable-area system continues to gain favor as a means of making original recordings. The Republic Studios have converted their recorders from class *A* push-pull to class *B* push-pull. After several months of production experience with this system, the studio has reported an appreciable reduction in noise, an improvement in quality, and a simplification of the recording operations.¹⁵ Extensive tests have also been made with the class *B* system at Warner Bros. Studios and at the Walt Disney Studios.

Improvements in the performance of RCA noise-reduction amplifiers have been made through the use of exponential tubes. By increasing the margin for low-level sounds, it is possible to use smaller bias lines, thus affecting a substantial reduction in ground-noise during quiet passages. Initial clipping is also reduced by this new development. Exponential noise-reduction systems are in use at RKO Studios, Walt Disney Studios, and the Republic Studios.

A new high-fidelity cutting head (*MI-4887*) was introduced by RCA. It is similar in design to the *MI-4885* cutting head except that the frequency range has been extended from 7500 cycles per second to 10,000 cycles per second. The new head may be used to cut either wax or lacquer disks (Fig. 13).

(3) *Recording Methods*.—RCA have described methods for securing amplitude control in variable-density recording by optical means.¹⁶ Further use of class *B* push-pull variable-density recording has also been related.¹⁵

Factors entering into recording and reproducing system characteristics which relate the effort employed by a speaker on the set to a proper reproduction of the same speech in the theater have been investigated.¹⁷

Two interesting methods of producing artificial reverberation have been described. In the first,¹⁸ the material to which reverberation is to be added is recorded upon a steel tape. A number of reproducing heads are separated by appropriate time intervals along the tape, so that when reproduced, multiple sources are obtained. The outputs are separately attenuated, thus simulating reverberation. The second method¹⁹ employs an electro-optical system. Here the material is recorded on phosphorescent material coated on the rim of a revolving turntable. The images are transitory, and by scanning the images at appropriate intervals, a time delay and decay in volume output from these image sources are obtained.

At the ERPI West Coast Laboratory an outdoor microphone test set-up has been established (Fig. 14). The equipment is similar to that employed by Western Electric and the Bell Telephone Laboratories, thus

making possible comparable measurements by the manufacturer, designer, and user of microphones. In addition to use in checking the performance characteristics of microphones, correlation between listening tests and acoustic measurements has established criteria which indicate a microphone's acceptability for sound recording from its measured acoustical response.

(III) SOUND AND PICTURE REPRODUCTION

During the year 1939 there has been little to report in the way of new sound picture projection equipment. However, installation of systems previously reported continued at a good pace throughout the country. Several pieces of auxiliary equipment were developed through the year.



FIG. 13. RCA 10,000-cycle recorder head.

A new preview attachment (*MI-1075*) was introduced by RCA. It consists of a single lower magazine for a 35-mm theater type projector. The new magazine accommodates three 1000-ft. reels for use when the sound and picture are simultaneously reproduced from



FIG. 14. ERPI West Coast outdoor microphone test set-up.

separate films. For normal projection of a composite print, space is provided for a 2000-ft. reel (Fig. 15).

The year 1939 has again demonstrated the outstanding values of the Simplex *E-7* projector mechanism which was first marketed during 1938. The introduction of dual shutters operating on the same shaft has made practical, through optical inversion, a total reduction in shutter blade area of 40 degrees, thereby appreciably increasing the

picture brilliancy with a given light-source. Other important features include: a removable fire-trap; a "one-shot" pressure oiling system completely filtered to prevent foreign matter from getting to the bearings through the lubricating system; automatic locking of the gate in either the open or closed positions; convenient means for ad-

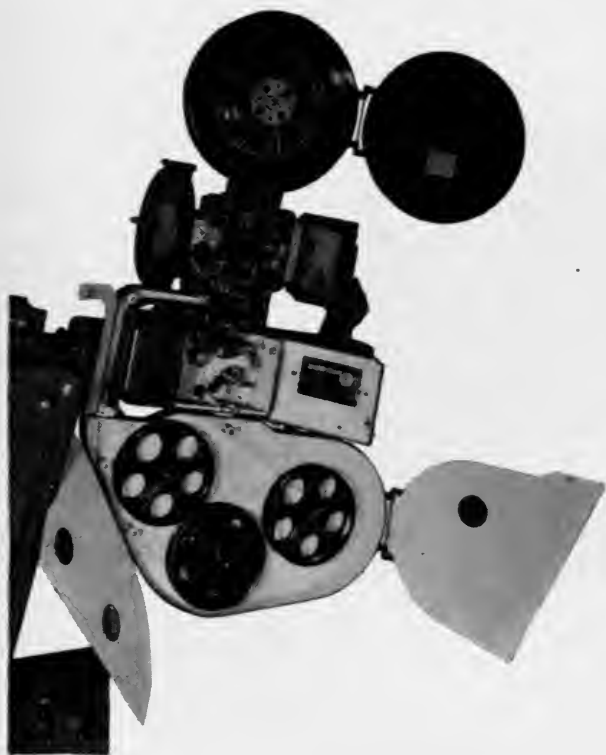

FIG. 15. RCA preview attachment.

justing the film tension; and improved intermittent movement and sprocket, hardened and ground to such precision as greatly to reduce the movement of the picture at the aperture.

The Simplex Four-Star Sound System, introduced during 1938, continued to be very popular with exhibitors during 1939. Most prominent among its design features are the ease of servicing, facilities for accurate adjustments, and the stability of its operating charac-

teristics. Other innovations such as the extensive use of feedback and the reduction in the number of transformer-coupled circuits, resulted in a pronounced improvement in the matter of both amplitude and phase distortion. Pioneered in this country was the use of permanent magnet loud speakers, a feature which further emphasizes the Simplex theme of simplicity and stability.

During 1939 International Projector Corporation introduced a completely new projection and sound equipment for the smaller type



Fig. 16. Luckiesh-Holladay Brightness Meter (Courtesy General Electric Co.).

of theater. The Simplex *SI* projector, together with a new low-cost pedestal of the rectangular box type and two lamp houses known as the Simplex Low and Simplex High, provide an attractive line of quality apparatus for a very large market. Simultaneously with this came the Type *E* Four-Star Sound System which was designed to provide the same grade of high-quality reproduction for the smaller theaters as has been available in the past only to the larger and *de luxe* houses. In carrying out their design premises, this system furnishes exactly the same sound head as is used in all of the other Simplex Four-Star Sound Systems. In addition, the identical type of permanent-magnet loud speaker units are used

and the circuit features are fundamentally the same. The cost reduction of this system was primarily obtained through the use of a-c for energizing the exciter lamp, one common volume control amplifier instead of individual ones for each machine, cabinet and mounting arrangements, and the use of smaller multicellular high-frequency horns made possible by an 800-cycle dividing network.

A new inexpensive brightness meter (Fig. 16) known as the Luckiesh-Holladay meter has recently been made commercially available by the General Electric Company. This covers a range of from $1/100$ of a foot-lambert to 75,000 foot-lamberts, and employs the familiar

concentric spot field, part of the field being the object whose brightness is measured, and part by a small battery-operated lamp whose brightness is adjusted by means of a photocell-operated light-meter. It has already proved to be a useful instrument for motion picture screen brightness measurements as well as for general brightness surveys in the theater.

Projector Lenses.—The application of a non-reflecting coating surface to projection lenses similar to that discussed previously for camera lenses has been discussed by Prof. C. H. Cartwright of Massachusetts Institute of Technology, and was demonstrated before the Atlantic Coast Section of the Society. The demonstration showed the difference between the new film-treated lens and a standard projection lens. Two matched films of the same subject were projected simultaneously upon a single screen by two projectors, one equipped with a treated lens and the other with an untreated lens. Half of the film was masked in each projector and the halves matched on the screen, allowing visual comparison of the light-transmission of the two lenses.

Miscellaneous.—The past year has witnessed an increasing use of fluorescent materials, activated by ultraviolet light, both in motion picture photography and in the theater. Probably much of this has been due to the recent availability of simple, powerful, ultraviolet sources as well as improvements in the fluorescent materials themselves. Lamps used for this purpose are of the electric discharge type of 100 and 25-watt rating. The filtering material that removes the visible radiation may be incorporated in the lamp bulb glass or in a roundel covering the front of the projector. One of the latest stunts is to impregnate the aisle carpets used in motion picture theaters with fluorescent material. Under the excitation from invisible ultraviolet projectors, the carpet glows with sufficient brightness to guide the patron down the darkened aisle.

(IV) TELEVISION

(1) *General.*—Regular television service to the metropolitan New York area from a transmitter on the Empire State Building was inaugurated on an experimental basis on April 30, 1939, with fanfare coincident with the opening of the New York World's Fair. At about the same time television receivers by a number of manufacturers were offered for sale in the New York area. Transmissions have averaged approximately eleven hours per week of entertainment features plus a somewhat greater number of hours of test-pattern signals. Much

work has been done on the development of program production technique and a systematic study of audience reaction to the individual programs. Transmissions have been in accordance with the standards recommended by the Radio Manufacturers Association. Technical performance was considered satisfactory. The antenna is of a type having a uniform impedance over a band greater than one television channel as a result of its unusual configuration. The vestigial



FIG. 17. Three AH-6 water-cooled lamps in single reflector (Courtesy General Electric Co.).

sideband signal is obtained by a special filter network at the output of the transmitter. A second New York station was nearly completed. Experimental transmissions were also available in the Los Angeles, Chicago, Philadelphia, and Schenectady areas. Television demonstrations were features of both the New York and San Francisco Fairs and attracted large crowds at other places.

Announcement was made of the development of a new type of pick-up tube which uses a low-velocity electron scanning-beam with resultant great improvement in image quality through the elimination of extraneous signal components.

Programs picked up at points remote from the studio have become so popular that a new type portable equipment in suitcase form has been developed, manufactured, and put into service in the New York and Los Angeles areas. Some of the cameras for this service use a small Iconoscope to make possible a small and light unit. A number of simplified television studio systems were built and used at fairs and exhibitions. It was found practicable to use short lengths of selected regular telephone circuits for the transmission from the remote point to the transmitter.



FIG. 18. Scene being televised with cool light from water-cooled quartz mercury arc lamp, in G-E Television Studio, Schenectady, N. Y.

Two reports dealing with problems in television broadcasting were issued by the television committee of the Federal Communications Commission.

A beginning was made in industry coöperation toward reduction of various types of interference to television and other ultra-high-frequency services.

Research continued on apparatus for large screen television and a number of showings were made to indicate status and progress.

(2) *Lighting*.—The lighting of the people being televised at the RCA exhibit at the World's Fair was accomplished by reflector incandescent lamps of 300-watt rating, described in detail in Mr. Eddy's paper²⁰ given before the 1939 Spring Meeting of the Society.

Three Type *H-6* water-cooled lamps²¹ were used to light the television studio in the General Electric exhibit (Fig. 17). Two incandescent spots, with heat-absorbing glass filters, were added to improve the appearance.

Early in June, General Electric's experimental television studio at Schenectady began operation. For lighting the area in which the action occurs, twelve Type *H-6* water-cooled lamps, arranged three to a reflector, are being used (Fig. 18). The purpose of putting three lamps in a single reflector is to minimize the effect of the cyclic variation of the light, each lamp being placed on the leg of a three-phase circuit. This installation is capable of providing 1000 to 1200 foot-candles over an area 12×12 feet.

(V) PUBLICATIONS AND NEW BOOKS

A new publication of interest to motion picture technicians made its debut in June, 1939, under the name, *Photo Technique*, published by McGraw-Hill Book Company. A German technical journal also made its initial appearance during 1939, its title being *Zeitschrift für Angewandte Photographie* and its publisher, S. Hirzel of Leipzig.

The following books of noteworthy interest were published since the last report of the Committee in April, 1939:

- (1) Handbook of Photography; K. Henney and B. Dudley (*McGraw-Hill Book Co., New York*).
- (2) The Photographic Process; J. E. Mack and M. J. Martin (*McGraw-Hill Book Co., New York*).
- (3) Colour Cinematography; A. Klein (Second Edition) (*Chapman and Hall, London*).
- (4) Colour in Theory and Practice; H. D. Murray and D. A. Spencer, Vol. 1 (*Chapman and Hall, London*).
- (5) Sound Motion Pictures, Recording and Reproducing; J. R. Cameron (*Cameron Publishing Co., Woodmont, Conn.*).
- (6) The Amplification and Distribution of Sound; A. E. Greenless (*Chapman and Hall, London*).
- (7) Tonfilm-Anlagen und ihre Behandlung (Sound-Films and Their Treatment); F. Kleffel (*W. Knappe, Halle, Germany*).
- (8) Applied Acoustics; H. F. Olson and F. Massa, 2nd Edition (*P. Blakiston's Son and Co., Philadelphia*).
- (9) Motion Pictures and Radio (of educational interest); E. Lane (*McGraw-Hill Book Co., New York*).
- (10) Make Your Own Movies; A. Gale and K. Pressels (*Coward-McCann Co., New York*).
- (11) Facts and Figures for the Amateur Cinematographer; G. P. Kendall (*Newnes, London*).

(12) Cine-Photography for Amateurs; J. H. Reyner, 3rd Edition (*Chapman and Hall, London*).

(13) Professional Quality on Amateur Reversal Film; P. C. Smethurst (*Link House Publication, London*).

(14) Photography by Infrared; W. Clark (*Chapman and Hall, London*).

(15) Electron Optics in Television; I. G. Maloff and D. W. Epstein (*McGraw-Hill Book Co., New York*).

(16) Television; V. Zworykin and G. A. Morton (*J. Wiley and Sons, New York*).

(17) The Cinema as a Graphic Art; V. Nilsen (Trans. by S. Gary) (*Newnes, London*).

(18) The History of Photography; E. Stenger (Trans. with footnotes by E. Epstean (*Mack Printing Co., Easton, Penna.*)).

Yearbooks were issued by the following publishers:

Quigley Publishing Co., New York.

Film Daily, New York.

Kinematograph Publications, Ltd., London.

Photo-Kino Verlag, Berlin.

M. Hess, Berlin-Schonberg.

Abridgments and compilations were issued as follows:

Abridged Scientific Publications of the Kodak Research Laboratories, Vol. 20 (1938) (*Eastman Kodak Company, Rochester, New York*).

Jahresbericht der Photographie, Kinematographie und Reproduktionstechnik für das Jahr 1937 (Review of Photography, Cinematography and Reproduction Processes for the Year 1937); H. Frieser and H. Staude (*Akademische Verlags M. B. H. Leipzig*).

Veröffentlichungen des wissenschaftlichen Zentral-Laboratoriums der Photographischen Abteilung—Agfa (Publications of the Agfa Central Photographic Research Laboratories), 6 (*S. Hirzel, Leipzig*).

REFERENCES

¹ Veroff. Wiss., *Zentral Labs. Phot. Abte. Agfa*, 6 (1939), p. 65.

² *Internat. Proj.*, 14 (April, 1939), p. 10.

³ *Phot. Ind.*, 37 (March 22, 1939), p. 403; also *Filmtechnik*, 14 (Oct., 1938), p. 173.

⁴ *Kino. Photo. Chem. Ind.* (U.S.S.R.), 21 (1939), No. 5.

⁵ *Publ. Sci. Tech. Ministere de l'Air*, Bull. Services Tech. No. 86 (1939).

⁶ *Phot. J.*, 79 (May, 1939), p. 330; 79 (July, 1939), p. 463; 79 (Nov., 1939), p. 609; 79 (Dec., 1939), p. 630; 80 (Jan., 1940), p. 12.

⁷ INMAN, G. E., AND ROBINSON, W. H.: "The Fluorescent Lamp and Its Application to Motion Picture Studio Lighting," *J. Soc. Mot. Pict. Eng.*, XXXIII (Sept., 1939), p. 326^o.

⁸ *Kinemat. Weekly*, 265 (March 30, 1939), p. 37; also *Internat. Phot.*, 10 (Jan., 1939), p. 10.

⁹ *J. Soc. Mot. Pict. Engs.*, XXXIV (Jan., 1940), p. 3; also *Internat. Phot.* 11 (Oct., 1939), p. 5.

¹⁰ *Amer. Cinemat.*, 20 (Dec., 1939), p. 535.

¹¹ *J. Soc. Mot. Pict. Engs.*, XXXIV (Jan., 1940), p. 12.

¹² DUDLEY, H.: "Remaking Speech," *J. Acous. Soc. Amer.*, (Oct., 1939), p. 169.

¹³ ARGUIMBA, L. B.: "Network Testing with Square Waves," *General Radio Experimenter*, XIV (Dec., 1939).

¹⁴ FRAYNE, J. G., AND SCOVILLE, R. R.: "Analysis and Measurement of Distortion in Variable-Density Recording," *J. Soc. Mot. Pict. Eng.*, XXXII (June, 1939), p. 648.

¹⁵ BLOOMBERG, D. J., AND LOOTENS, C. L.: "Class B Push-Pull Recording for Original Negatives," *J. Soc. Mot. Pict. Eng.*, XXXIII (Dec., 1939), p. 664.

¹⁶ DIMMICH, G. L.: "Optical Control of Wave-Shape and Amplitude Characteristics in Variable-Density Recording," *J. Soc. Mot. Pict. Eng.*, XXXIII (Dec., 1939), p. 650.

¹⁷ LOYE, D. P., AND MORGAN, K. F.: "Sound Picture Recording and Reproducing Characteristics," *J. Soc. Mot. Pict. Eng.*, XXXII (June, 1939), p. 631.

¹⁸ WOLF, S. K.: "Artificially Controlled Reverberation," *J. Soc. Mot. Pict. Eng.*, XXXII (April, 1939), p. 390.

¹⁹ GOLDMARK, P. C., AND HENRICKS, P. S.: "Synthetic Reverberation," *J. Soc. Mot. Pict. Eng.* XXXIII (Dec., 1939), p. 635.

²⁰ EDDY, W. C.: "Television Lighting," *J. Soc. Mot. Pict. Eng.*, XXXIII (July, 1939), p. 41.

²¹ NOEL, E. B., AND FARNHAM, R. E.: "A Water-Cooled Mercury Arc," *J. Soc. Mot. Pict. Eng.*, XXXI (Sept., 1938), p. 221.

CHEMICAL ANALYSIS OF PHOTOGRAPHIC DEVELOPERS AND FIXING BATHS*

R. B. ATKINSON AND V. C. SHANER**

Summary.—Procedures for the qualitative and quantitative determination of the usual constituents of photographic developers and fixing baths are given. Volumetric methods are employed in general.

The accuracy of the procedures and the significance of analytical findings are discussed in relation to the functions of the various constituents of developers and fixing baths, both when fresh and after use. Suggestions are given as to the manner of application of analytical tests to typical cases of troubles arising from defective processing baths.

The selection of reagents, the use of special procedures and equipment, and the computation of results are treated in detail.

INTRODUCTION

Photography has developed from infancy as an art rather than a science, and it is only with the demands for uniformity and economy which come with large-scale commercial applications that the science of photography has been given attention. Photographic materials go through three important stages in their use, namely, manufacture, exposure in the camera or other mechanism, and processing. Scientific methods have been introduced widely into the first two phases of photography, and in recent years sensitometric control has been applied extensively in certain types of photographic processing, especially in handling motion picture film. The final stage to which scientific control has come is processing. One reason for this tardiness is the fact that the process is complicated, and adequate tools have only recently been developed. Primary among such tools are analytical methods for the study of the solutions themselves. Such methods have been worked out on a practical basis with special reference to motion picture solutions, and the methods here described have been found useful in handling problems of the motion picture film laboratories.

* Presented at the 1940 Spring Meeting at Atlantic City, N. J.

** Eastman Kodak Co., Hollywood, Calif.

The analysis of photographic processing solutions may be of great assistance to the laboratory chemist from several standpoints such as:

- (1) A complete chemical check-up of all solutions prepared by him prior to their actual production use.
- (2) A definite aid in maintaining uniformity of photographic results through properly maintained solutions.
- (3) A check on solutions having unusual chemical behavior.
- (4) A direct saving from the economic standpoint through more efficient use of chemicals and elimination of undue waste.

Previous Work on the Chemistry of Processing Solutions.—The analysis of organic developing agents has been described by H. T. Clarke¹ in his work, "The Examination of Organic Developing Agents," Ermen² in "Qualitative Tests for the Commoner Developers," and Plaumann³ in "Erkennung von Entwicklernsubstanzen."

The original work which was done on the correlation of developer activity and chemical constitution throughout the useful life of a developer was by Lehmann and Tausch.^{4,5}

Evans⁶ in his paper, "Maintenance of Developer by Continuous Replenishment," discusses the application of analytical controls to developer maintenance. Two more recent papers by Evans and Hanson⁷ and Evans and Silberstein⁸ discuss practical methods of developer analysis to be used by motion picture laboratories.

H. L. Baumbach⁹ discussed the determination of elon, hydroquinone, and bromide by volumetric methods in a recent article in THIS JOURNAL.

Standard texts in the field of inorganic chemistry are Prescott and Johnson¹⁰ and Treadwell and Hall,¹¹ for organic analysis Kamm¹² and the Association of Official Agricultural Chemists,¹³ and in the field of microchemistry Benedetti-Pichler-Spikes¹⁴ and Chamot and Mason.¹⁵

PART I DEVELOPERS

Methods are given for analyzing for the following developing agents:

<i>Trade Name</i>	<i>Chemical Name</i>
Elon	Monomethyl <i>p</i> -aminophenol sulfate
Hydroquinone	Quinol
Pyro	Pyrogallol
<i>P</i> -a. p., Kodelon	<i>p</i> -Aminophenol oxalate
Glycine, Athenon	<i>p</i> -Hydroxyphenyl glycine

Amidol

2,4-Diaminophenol hydrochloride

P-Phenylenediamine*p*-Phenylenediamine hydrochloride

NOTE: These compounds will be referred to in this paper by the names commonly used in the trade.

ANALYSIS OF DEVELOPERS FOR DEVELOPING AGENTS

When dealing with used developers, it is necessary to distinguish between the original developing agent and its oxidized form. In the

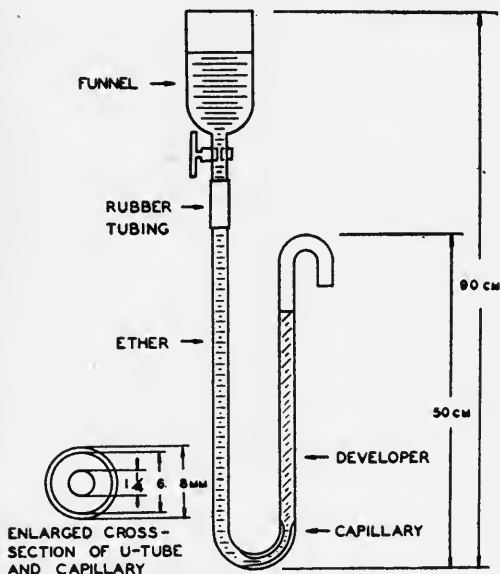

FIG. 1. U-tube extractor.

specific cases of elon and hydroquinone, it has been fairly well established that they are oxidized to their respective sulfonates, and these are formed when oxidation is effected by either oxygen or silver bromide. Careful work has indicated that these sulfonates are themselves developing agents but that they may be safely neglected in first-order approximations of the developer activity.

The sulfonates are more soluble in water than the original developing agents, while the reverse is true in organic solvents, so that elon and hydroquinone may be separated from their sulfonates by extracting them from an aqueous solution with ethyl ether or ethyl

acetate. No other suitable method has been found, so extraction of the unoxidized developing agents becomes the first step in any developer analysis.

A separatory funnel manually operated is adequate for qualitative tests. This may also be suitable for control purposes if the manual extraction is carried out under standardized conditions. This may not, however, give sufficient precision for quantitative methods, and a special extractor has been found preferable.

The extractor is illustrated in Fig. 1. It consists of a 150-ml cylindrical glass funnel with stopcock, connected by rubber tubing to a glass *U*-tube. The *U*-tube is blown with a capillary at the bottom, which provides for the formation of small bubbles of the extracting solvent and thus insures efficient extraction. One end of the *U* is bent to allow the solvent to run into a receptacle. The dimensions of the tube are important, and those given in Fig. 1 have proved satisfactory for the analysis of 5.0-ml samples of developer. This size sample is suitable for the average motion picture developer, but for abnormal developers the dimensions can of course be altered.

When the extraction method is used, developing agents divide themselves into two classes. The first class contains the agents which are free organic compounds, typified by hydroquinone, and the second class contains those agents which are the salts of an organic base and a strong acid, typified by elon. The distinguishing property between these classes is that the former may be extracted from any aqueous solution by an organic solvent such as ethyl ether or ethyl acetate. The second class, however, is made up of agents which are themselves insoluble in these solvents, but whose organic bases are soluble. In order to extract agents of the second class from aqueous solution it is necessary that the free base be present in the solution. The maximum concentration of elon base occurs at a *pH* value of approximately 8.0. Extraction with a solvent then removes from solution the organic base, and it is possible to determine the weight, or other property, of the free base and thus determine quantitatively the amount of developing agent originally present in the solution.

HYDROQUINONE

Hydroquinone, also known as quinol, or 1,4-dihydroxy benzene, is widely used as a developing agent, generally in combination with elon. In appearance it is white, usually crystallized in thin needles, readily soluble in water and ethyl ether.

Although hydroquinone is commonly used with elon, it differs from it photographically. In carbonate developers, hydroquinone is a powerful developer producing images of great contrast. Its activity drops rapidly with decreasing pH , and hydroquinone alone will not develop in a borax developer. In combination with elon, however, hydroquinone does serve as a reducing agent even in a borax developer.

Qualitative Tests for Hydroquinone.—Hydroquinone may be distinguished from elon and other salts of organic bases by the fact that it is readily soluble in ether, while the latter are not. The addition of ferric chloride solution to a concentrated solution of hydroquinone will cause it to turn dark brown (elon solution turns purple) and quinone is formed. This may be detected by the pungent odor given off on heating. Hydroquinone crystals have a definite melting point at $169^{\circ}C$, and this may be used as a positive means of identification.

Quantitative Determination of Hydroquinone.—The determination of hydroquinone in a developer is performed with the aid of the *U*-tube extractor described above.

A suitable sample (5.0 ml) is pipetted into the funnel of the extractor, with the stopcock closed. One drop of a 0.04 per cent solution of thymol blue indicator is added, and concentrated hydrochloric acid added drop by drop until the color has changed from yellow to red.

At this point the pH value is approximately 2, where hydroquinone is soluble in ether but elon is present in an insoluble form. Enough dry sodium chloride is added to saturate the solution, plus a slight excess. This decreases the solubility of the hydroquinone in the water, and the excess aids in obtaining the desired agitation during extraction. The stopcock is then opened, and ethyl ether added through the funnel. It is desirable to use C. P. rather than U. S. P. ether. The ether flow is regulated by the stopcock, and is allowed to run just fast enough so that the water layer is not carried out of the tube. When 100 ml of ether have been collected (a graduate is a suitable receptacle), water is added through the funnel and the ether remaining in the tube is carried over, without carrying over any developer.

A heavy-walled 500-ml flask is used for the titration. In it are placed 200 ml of hot water and 1.0 ml of concentrated hydrochloric acid. The ether is added to the flask, which is then connected to an aspirator and the ether removed by vacuum. The hydroquinone is dissolved by the water. If an aspirator is not available, the ether

may be driven off by heating the flask, taking care not to ignite the ether vapor. The solution must be cooled to room temperature before titrating.

When the ether is removed, add 2 ml starch solution and titrate with 0.01 normal iodine. This serves to remove any sulfur dioxide which is present, and also establishes the blank for the titration. The value is not recorded. Because the solution is acid, the hydroquinone will not react with the iodine.

A buffer solution is now used, containing 30 grams of crystalline disodium phosphate and 10 grams of Kodalk per liter. One hundred ml of this buffer solution are added to the flask after the first iodine titration. This raises the *pH* of the solution to approximately 7.5, where both elon and hydroquinone will react with iodine. The blue color will be bleached by the hydroquinone which is now reactive, and a second titration is carried out, this time recording the value.

The titration should be carried just far enough to give a permanent blue color, which will not fade in at least one minute. The concentration of hydroquinone in the developer may then be calculated from the following equation:

$$\frac{\text{volume of iodine} \times \text{normality of iodine} \times 55}{\text{volume of sample}} = \text{grams of hydroquinone per liter of sample}$$

If the normality of iodine used is 0.01 and a 5.0-ml sample is taken, the answer is obtained by multiplying the ml of iodine required by 0.11.

The precision of this method may be increased slightly if a small excess of iodine is added to the hydroquinone solution, and the value determined after back-titrating with thiosulfate solution.

ELON

Elon is widely used as a developing agent, generally in combination with hydroquinone. By suitable adjustment of the developer formula, it is possible to obtain almost any desired photographic results using these two agents. Elon itself is a powerful developer, producing images of great density in a short time when used with carbonate as the alkali, and is sufficiently active to develop negatives in a borax developer of relatively low *pH* value.

Elon is the Eastman Kodak trade name for monomethyl para-aminophenol sulfate. The same compound is sold by other manu-

facturers under trade names such as Metol, Pictol, and Satrapol. Elon is a white crystalline compound readily soluble in water, but negligibly soluble in alcohol and ether. The free base of elon is a secondary amine, melting at 87°C. The free base may be extracted from a weakly alkaline solution. This method is generally followed in making either qualitative or quantitative tests for elon.

Qualitative Tests for Elon.—If the unknown is a dry powder it is dissolved in water in the presence of a 5 per cent solution of sodium sulfite. If the unknown to be examined is already in solution sulfite

TABLE I

Identifying Reactions of Developing Agents

Agent	Ferric Chloride (in Acid Solution)	Benzaldehyde (in Alkaline Solution)	Sodium Nitrite (in Acid Solution)
Elon (M. P. Elon base, 85°C)	Purple color de- velops slowly in cold	No ppt. if pure	Colorless needles slightly soluble in water, M. P. 136°C
Glycine (M. P. 200°C)	Darkens slowly in cold	No ppt.	No ppt.
Amidol (M. P. base, 79°C)	Bright red color immediately	Dirty yellow ppt. M. P. indeter- minate	Dark brown ppt.
<i>p</i> -Aminophenol (M. P. base, 184°C)	Purple color de- velops slowly in cold	Yellow ppt. M. P. 183°C	Red color with R-acid
<i>p</i> -Phenylenediamine (M. P. base, 140°C)	Green-blue, chang- ing immediately to brown	Yellow ppt. M. P. 138°C	Red color with R-acid

is added and the pH adjusted to approximately 8.0. At this point the ratio of the solubility of elon in ether and water is the greatest. The sample is shaken in a separatory funnel with an equal volume of ether. A few drops of the ether extract are placed on a piece of filter paper leaving the residue crystallized on the paper. A drop of sodium hypochlorite solution (16 per cent) is placed on the residue and a brilliant blue-green color is apparent immediately if elon is present. Most developing agents will give a strong color with this test and hydroquinone gives a transitory green color, but none gives the definite blue-green of elon, and a simple comparison with a known sample will make positive the identification of elon by this test.

Several common developing agents are also soluble in ether and may be extracted from alkaline solution by that solvent. In order to distinguish between these a number of identifying reactions are summarized in Table I. The residue from the ether extract is dissolved in water, a few drops of ferric chloride (10 per cent solution) are added to one portion, a few drops of benzaldehyde are added to another, and a third portion is acidified with sulfuric acid and treated with a solution of sodium nitrite. The results of these reactions with the various developers are given in Table I.

Quantitative Determination of Elon.—The principle used in determining elon in a developer is identical to that used for hydroquinone. In the absence of other developing agents, elon may be determined directly. Elon is commonly used, however, together with hydroquinone, and in this case it is necessary to determine the hydroquinone by the above procedure before the elon can be measured. The two agents are then removed simultaneously from an alkaline sample of the developer and the concentration of the two measured by titrating with iodine, the difference between the total measurement and the hydroquinone measurement being the elon value.

The procedure is as follows: 5.0 ml of developer are pipetted into the extractor funnel. The solution is saturated with salt, a drop of thymol blue solution is added, and 5 normal hydrochloric acid added drop by drop until the color just changes from blue to yellow. Care should be taken not to add too much acid. The pH value will be approximately 8.0, at which point both elon base and hydroquinone are soluble in ether. The procedure then duplicates that for hydroquinone—ether is run through until 100 ml have been collected, the ether remaining in the U-tube is run over, the ether extract added to acidified hot water, the ether removed by evacuation or boiling, the cool solution titrated with 0.01 *N* iodine, and the phosphate-Kodalk buffer solution added, exactly as for hydroquinone.

The titration is then performed to a permanent blue, and the iodine required will be proportional to the amount of developing agents present. The value of the iodine titration for hydroquinone alone is subtracted from the total, and the remainder is computed as elon according to the following equation:

$$\frac{\text{volume of iodine} \times \text{normality of iodine} \times 86}{\text{volume of sample}} = \text{grams of elon per liter of sample}$$

A sample analysis is illustrated: 5.0 ml of a developer were acidified and extracted for hydroquinone; 36.36 ml of 0.01 *N* iodine were re-

quired; 5.0 ml of the same developer were adjusted to a *pH* of 8.0 and extracted for both elon and hydroquinone; 42.17 ml of 0.01 *N* iodine were required. The calculation is as follows:

Iodine required for both	42.17 ml
for hydroquinone	36.36
for elon	5.81

$$\frac{36.36 \times 0.01 \times 55}{5} = 4.0 \text{ grams of hydroquinone per liter of developer}$$

$$\frac{5.81 \times 0.01 \times 86}{5} = 1.0 \text{ gram of elon per liter of developer}$$

Other Developing Agents.—While elon and hydroquinone are at present almost universally used for photographic developers, a number of other developing agents are available, and are sometimes used for special purposes. A few of these will be described briefly.

Para-aminophenol.—This developing agent, commonly called *p*-a.p., is quite similar to elon both photographically and chemically. The oxalate of para-aminophenol is sold by the Eastman Kodak Company as Kodelon, and is recommended to photographic workers who are susceptible to elon poison. From a photographic standpoint *p*-a.p. behaves like elon except that it has slightly less activity for a given *pH* value than elon.

P-a.p. will react to many of the qualitative tests for elon. It may be distinguished from elon by the fact that it is precipitated as the benzylidene derivative on the addition of benzaldehyde to an aqueous solution of the developing agent, while elon is not. *P*-a.p. may be determined quantitatively by extraction with ether from alkaline solution.

Glycine.—Glycine is used occasionally in photographic developers, generally in the presence of a strong alkali. It is less powerful than elon at equal *pH* values and does not give as much density. There is no special advantage to be gained from its use in motion picture processing.

Glycine is a trade name for *p*-hydroxyphenyl glycine. It is manufactured and sold by the Eastman Kodak Company as Athenon. In appearance it is cream colored and is found in flaky crystals. It is soluble in water only with difficulty, but is readily dissolved in the presence of alkali. Glycine burns completely when heated to redness, while elon does not.

Glycine may be extracted from alkaline solution with ethyl ether and determined quantitatively in the manner outlined above for elon.

Amidol.—Amidol is a powerful photographic developer capable of developing in neutral or slightly acid solutions and producing great density in alkaline solutions. It is apt to stain and will produce high fog density unless used appropriately.

Amidol is the trade name for diamino-phenol hydrochloride. In appearance it is a gray powder commonly giving a strongly colored solution. An amidol developer will darken rapidly on exposure to air even in the presence of excess sulfite, and when strongly oxidized a dye is formed which will stain film purple.

The addition of ferric chloride to a solution of amidol produces an intense red color (see Table I). Amidol may be determined quantitatively by extraction with ether from alkaline solution in the manner outlined for elon.

Para-phenylenediamine.—Para-phenylenediamine is not used in motion picture practice, but finds some application in fine-grain developers for still photography. It should be handled with caution because workers using it are very apt to develop skin poisoning. As a developing agent it is quite weak, requiring a strong alkali to produce even moderate images.

The identifying reactions of para-phenylenediamine are given in Table I. It may be determined iodometrically after extraction with ether from alkaline solution, in the manner outlined for elon above.

Pyro.—Pyro, or pyrogallol, once found wide application because it is a powerful developer giving brilliant images. It is no longer used, however, because of the objectionable stain formed by the oxidized pyro. However, pyro also exerts a tanning action on gelatin, and film developed in a pyro developer is tanned in proportion to the amount of silver present in a given area. This fact makes pyro useful in photographic processes involving imbibition.

Pyro is a nearly white crystal, readily soluble in water, alcohol, and ether, which distinguishes it from most other developing agents except hydroquinone. Pyro is readily distinguished from hydroquinone in that it melts at 132°C and the latter at 169°C. The rapid oxidation of pyro solutions to a strong red-brown color, even in the presence of sulfite, distinguishes pyro from most developing agents.

Pyro may be extracted from an acidified solution using ether as the solvent and weighing the extract. If hydroquinone is present pyro may be separated from it by precipitating the lead salt of pyro. After extraction with ether the residue is dissolved in water, the

solution acidified with acetic acid, and lead acetate solution added until the pyro is all precipitated. This is filtered off, dried, and weighed. In calculating the quantity of pyro from the weight of the lead precipitate the following equation is used:

$$1 \text{ gram of lead salt} = 0.333 \text{ gram of pyro}$$

SULFITE

While it is possible to develop a photographic image in a solution containing no sulfite, all developers in common use contain this ion. It is generally added as the sodium salt, or as sodium bisulfite, or both. The primary purpose of sulfite in developers is to prevent oxidation of the developing agents, but it serves at least two other purposes. It is a weak source of alkali and is used as such in negative developers. It acts as a solvent for silver bromide and in this capacity it helps start development. In general, increasing the concentration of sulfite in a developer increases the density obtained for a given degree of development, but has little effect on the rate of development.

The effect of adding bisulfite to a solution is simply to add sulfite in an acid rather than in an alkaline form. The net effect on the solution is to have the sulfite ion present but to have the *pH* of the solution lower than it would have been with the equivalent amount of sulfite.

Qualitative Test for Sulfite.—Sulfite ion is detected by acidifying a small portion of the developer solution. Sulfur dioxide is given off and may be detected by its characteristic odor, or by passing the gas by means of a delivery tube into a solution of potassium iodide and starch to which are added a few drops of iodine. If the blue color is bleached by the gas, sulfite is present in the developer.

Quantitative Determination of Sulfite.—The determination of sulfite is based on the reaction:



The sulfite concentration of a developer is determined as follows: A portion of the developer sample is placed in a 10-ml burette. A 300-ml flask is used for the titration. Put 25.0 ml of 0.1 normal iodine solution into the flask, add 5 ml of concentrated hydrochloric acid and 50 ml of water to the flask. Titrate developer from the burette until the brown color of the iodine is nearly bleached. Add 2 ml of starch solution and continue titrating the developer until the

blue color vanishes. In calculating the sulfite concentration the following equation is used:

$$\frac{(\text{ml iodine}) \times (\text{normality iodine}) \times 63}{\text{ml developer required}} = \text{grams of sodium sulfite per liter}$$

For example: If the titration required 5.65 ml of developer, using 25 ml of 0.100 normal iodine, the sulfite concentration was:

$$\frac{25 \times 0.100 \times 63}{5.65} = 27.9 \text{ grams sodium sulfite per liter}$$

Bisulfite, or metabisulfite, which in solution is bisulfite, will also react with iodine and can not be distinguished from sulfite in this respect. If bisulfite is suspected or supposed to be in the formula the simplest way it can be verified is to prepare a solution made up according to the formula found on analysis, assuming all sulfite found to have been added as sodium sulfite. The *pH* of the synthetic solution is compared with that of the original developer. If the original developer has a lower *pH* presumably part or all of the sulfite was added as bisulfite. The approximate quantity of bisulfite in the original formula can be determined in this manner: Mix the synthetic formula again, this time using the equivalent quantity of bisulfite instead of sulfite. By a series of trial and error experiments the relative quantities of sulfite and bisulfite necessary to give the correct *pH* may be approximated.

SULFATE

Sodium sulfate (Glauber's salt) is occasionally added to a developer, especially if it is designed for high-temperature processing. The purpose is to prevent excessive swelling of the emulsion. In analyzing for sulfate, however, it must be borne in mind that practically all commercial samples of sulfite contain appreciable amounts of sulfate and that a used developer originally made up with pure sulfite may contain as much as 10 to 20 per cent of the original weight of sulfite as sulfate. Hence in practice a test for sulfate in a developer will invariably be positive, but no sulfate may have been added as such. In this case the only useful information can come from a quantitative analysis. If such analysis shows sulfate to be present in amounts greater than, say, 5 per cent of the weight of sulfite found, sulfate may have been added intentionally. In cases where the degree of oxidation of the developer is in question, a knowledge of the sulfate concentration will be of value.

Qualitative Test for Sulfate.—While sulfate will undoubtedly be present in small quantities in all developers containing sulfite, it might be desirable to establish absolutely the presence of sulfate. A sample of developer is acidified with hydrochloric acid, heated to boiling, and a boiling solution of barium chloride is added. Barium sulfite may be precipitated, but it will soon be dissolved with the excess hydrochloric acid, and a permanent barium precipitate is an indication of sulfate. It must be remembered that elon contains the sulfate group and a positive test for sulfate will always be found in the presence of elon.

Quantitative Determination of Sulfate.—A good method for the determination of sulfate in the presence of sulfite requires the determination of the sulfite by titration with iodine. The practice followed in this Laboratory is to determine the sulfite by the method outlined above, adding the developer to the iodine until the end point is reached. The solution in the flask then contains what sulfate was originally present in the developer, and also contains as sulfate all the sulfite originally present. The solution is boiled to drive off carbon dioxide and an excess of hot barium chloride added to it. This solution is boiled for a minute to insure a coarse precipitate, then filtered through a weighed Gooch crucible. The precipitate consists entirely of barium sulfate. It is dried and weighed.

A sample calculation for sulfate originally present in the developer is given: In the example given above 5.65 ml of developer were required in the iodine titration, and the developer was found to contain 27.9 grams per liter of sodium sulfite. The weight of the barium precipitate was found to be 0.334 gram.

$$\frac{\text{grams sulfite per liter} \times \text{ml used in titration}}{1000} = \text{grams sulfite in titration} \quad (1)$$

$$\frac{27.9 \times 5.65}{1000} = 0.158 \text{ gram of sodium sulfite in 5.65 ml}$$

$$\text{grams sulfite in } X \text{ ml} \times \frac{\text{mol. wt. sulfate}}{\text{mol. wt. sulfite}} = \text{grams sulfate in } X \text{ ml} \quad (2)$$

$$0.158 \times \frac{142}{126} = 0.178 \text{ gram sulfate per 5.65 ml}$$

$$\text{wt. ppt. of barium sulfate} \times \frac{\text{mol. wt. sodium sulfate}}{\text{mol. wt. barium sulfate}} = \text{total grams sodium sulfate in } X \text{ ml} \quad (3)$$

$$0.334 \text{ gram} \times \frac{142}{233.4} = 0.203 \text{ gram sodium sulfate in 5.65 ml}$$

Total grams sulfate, less weight of sulfate due to sulfite = weight sulfate (4)
present as such

Subtracting (2) from (3)

$$\begin{array}{r} 0.203 \\ 0.178 \\ \hline \end{array}$$

0.025 gram sulfate originally in 5.65 ml

$$\text{grams in } X \text{ ml} \times \frac{1000}{X} = \text{grams per liter of sodium sulfate} \quad (5)$$

$$\frac{0.025 \times 1000}{5.65} = 4.42 \text{ grams per liter anhydrous sodium sulfate present in original sample}$$

CARBONATE

Sodium carbonate is the common alkali in motion picture positive developers as well as many other photographic developers. Anhydrous sodium carbonate is a fine white powder. Monohydrated carbonate, a fine white crystal, is widely used because it is less apt to cake than anhydrous carbonate and is less dusty. Its equivalent weight is 17 per cent greater than that of anhydrous sodium carbonate and the analyst must be careful to specify which carbonate is reported from an analysis. Potassium carbonate is rarely used today. It is more soluble than sodium carbonate and is held by practical workers to be a more powerful alkali than sodium carbonate. Since this is not consistent with chemical theory it is undoubtedly due to the fact that there is a higher content of free caustic in commercial potassium carbonate than in commercial sodium carbonate.

From the photographic standpoint, carbonate is a most useful alkali. It provides the desired *pH* for the efficient use of elon and hydroquinone and yet does not have the softening effect on film of more powerful alkalies. Increasing the concentration of carbonate is a simple means of increasing the activity of a developer. Positive developers made up with carbonate are highly resistant to changes in alkalinity, and for this reason positive developers do not appear as variable as negative developers.

Qualitative Tests for Carbonate.—Carbonate may be detected by the evolution of carbon dioxide from an acidified solution. The evolved gas may be delivered into a solution of barium chloride. Carbon dioxide will cause the precipitation of a fine white precipitate, barium carbonate. Sulfur dioxide will also precipitate barium, and if it is necessary to distinguish carbonate in the presence of sulfite the unknown solution is first treated with an excess of potassium dichromate

and then acidified. The sulfite will be oxidized, and no sulfur dioxide will be evolved on acidifying but carbon dioxide will still be evolved if carbonate is present.

Quantitative Determination of Carbonate.—The quantity of carbonate in a developer may be determined precisely by oxidizing the sulfite, acidifying, and driving off the carbon dioxide, absorbing it in sodalime, and calculating the quantity of carbonate present from the gain in weight of the sodalime. A suitable apparatus for applying this method is illustrated in Fig. 2.

Referring to Fig. 2, *B* and *J* are gas absorbers, and are filled with sodalime, or Ascarite. *C* contains hydrochloric acid for decomposing the carbonate. *G* is empty and is for condensing moisture. *H* is

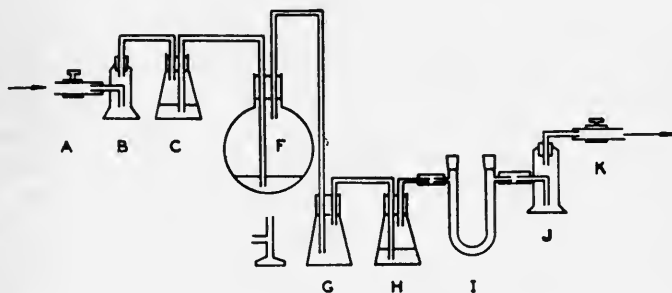
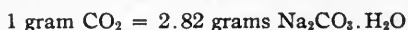
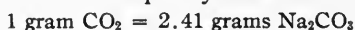

FIG. 2. Apparatus for determining carbonate.

partly filled with a concentrated solution of potassium dichromate and sulfuric acid which serves to oxidize the sulfur dioxide to sulfate so that it does not interfere in the determination of the carbon dioxide. *I* is the drying tube. Dehydrite, or Drierite, is preferable to calcium chloride as the drying agent.

Before use the flasks *C* and *F* are emptied, stopcock *A* is closed, and *K* connected to a vacuum line. After emptying the system *K* is closed and no bubbles should appear in *H* if the system is tight. When the system is in order enough 5 *N* hydrochloric acid is placed in flask *C* to decompose the carbonate present in the developer sample. Twenty-five ml of the developer to be analyzed are placed in the flask *F*. A few drops of thymol blue indicator may be added to the developer so that on the addition of the acid the operator may be certain that all the carbonate has been converted to carbonic acid. The indicator should be red when this has occurred. *K* is connected

to the vacuum line and air drawn through the system so that about two bubbles per second pass through *H*. The acid is drawn over from *C* to *F* decomposing the carbonate, and the carbon dioxide generated passes through the system to be absorbed in *J*. The sulfur dioxide remains in the form of sulfate in the flask *H*. The mixture in *F* is slowly heated, taking care not to drive any solution back toward *C*. After boiling for a minute the flame is removed and air passed through for 20 minutes more to insure sweeping out all the carbon dioxide. *J* is weighed before and after the process and the gain in weight is carbon dioxide. This value may be used to obtain the weight of carbonate present in the sample by means of the following equation:



HALIDES

Bromide, chloride, and iodide, collectively known as halides, play important roles in photography. The silver salts of these elements are all light-sensitive and all ordinary photographic emulsions are made up of one or more of the silver halides. It is common knowledge that the bromide concentration in a developer must be carefully adjusted for satisfactory results. In most cases, the chloride concentration is less important, because chloride does not exert the restraining action which bromide does. On the other hand, iodide in a developer exerts an overwhelming influence. The low solubility of silver iodide, however, causes any free iodide in a developer to react with silver ion in the emulsion and be immediately removed from solution. For this reason the restraining effect of iodide is seldom encountered. Iodide is added to a fresh developer only when the initial fog value is excessive. Chloride is rarely added to fresh developers, but bromide is universally used as an antifogging or restraining agent in developers.

Qualitative Tests for Halides.—It may be desired to determine whether a solution contains one or more of the halides. Because of the similarity of the properties of all halide salts it is difficult to identify them in the presence of each other; however, several identifying reactions will be outlined and may prove useful.

A developer may be tested quickly for the presence of halide by acidifying with an excess of nitric acid, adding a little silver nitrate solution, and boiling. A light-colored precipitate remaining after boiling indicates one or more halide present.

To an unknown solution to be tested for halides, acidify with sulfuric acid, add a few drops of starch solution and a few drops of a solution of ammonium persulfate, or potassium nitrite. The oxidizing agent will release iodine from any iodide present, and the starch will be colored blue. This will identify iodine in the presence of bromide and chloride. If iodine is absent bromide may be identified by the same reaction in which case the starch will be colored yellow. This effect will be masked in the presence of iodine, but will determine bromide in the presence of chloride. A definite reaction for the determination of chloride in the presence of bromide is the chromyl chloride reaction. The halide is precipitated by silver nitrate in the presence of nitric acid, and the precipitate filtered and dried. The dry silver halide is added to a hot concentrated solution of potassium dichromate and sulfuric acid. If a compound of chlorine is present chromyl chloride will be formed. This compound volatilizes at 115°C and the brownish red fumes are easily seen. In case of doubt the distillate should be cooled and a test for chromate ion applied. The reaction between chromic acid and silver chloride will proceed slowly because of the low solubility of silver chloride, but this test is a positive identification for chlorine compounds even in the presence of other halides. By a combination of these methods, all three halides may be determined.

Quantitative Determination of Halides.—The standard method for the determination of halide is to titrate with silver nitrate. Enough silver nitrate solution is added to precipitate all the halide present plus a slight excess. This excess is determined by back-titrating with a solution of potassium thiocyanate using ferric ammonium alum as indicator. While this method may be applied to the determination of any halide it is awkward to use in determining the bromide concentration in a photographic developer, and an improved method for the determination of bromide has been worked out in this Laboratory. This method is open to the objection that it does not give true values in the presence of chloride and iodide. Chloride in addition to bromide is likely to be present in small quantities in most present-day emulsions, and will, therefore, be found in small quantities in all used developers. As explained above, iodide will not be found in significant concentrations in used developers.

Adsorption Method for the Determination of Total Halides as Bromides.—This method has been used in this Laboratory for more than three years and has been used successfully in several motion picture

laboratories. Our experience has led to the conclusion that the method is sufficiently reliable for all practical purposes and that an average error of about 5 per cent is all that is likely to occur from the interference of chlorides. An extreme error of 10 per cent due to other halides has been encountered. Precise tests made on the effect of bromide concentration in both negative and positive developers show that a 10 per cent variation in bromide concentration causes at the most a difference of 0.02 in gamma or density for a given time of development. Experience has shown that when used as a control on the same type of developer, the observed value may be taken for true bromide with practically no resultant photographic error. Another method is given for the determination of bromide in the presence of chloride, and this may be used to establish the validity of the adsorption method.

A 100-ml sample of developer is placed in a 300-ml flask. One hundred ml of distilled water are added, and 15 ml of concentrated nitric acid (enough acid to neutralize the developer and approximately 10 ml excess) and 4 ml of 0.2 per cent solution of metanil yellow. The color of the solution will be red. Add 10 ml of a solution of potassium bromide containing 10.0 grams per liter. The solution in the flask is then titrated with a standard solution of silver nitrate which contains 14.27 grams of silver nitrate per liter. Immediately upon the addition of the silver the solution will turn blue due to the adsorption of the dye on the silver bromide precipitate. At the end point of the titration the color change will be from blue back to the original red, and the precipitate of silver bromide will coagulate. The color change is due to the fact that in the presence of an excess of silver ion the dye adsorbed to the precipitate is red, but in the presence of an excess of halide ion the dye is blue.

The known quantity of bromide is added to the developer originally so that a sufficient amount of precipitate will be present to insure a good end point. This procedure may be omitted in testing developers which have more than one gram per liter of bromide. The standard solutions are made up so that the value of bromide in the sample may be determined by dividing the net consumption of silver solution by ten. For example, if 22.50 ml of silver nitrate solution are required to react with a 100-ml sample of developer to which are added 10 ml of standard bromide solution,

$$\begin{array}{r} 22.50 \text{ (ml AgNO}_3\text{)} \\ 10.00 \text{ (ml KBr)} \\ \hline 12.50 \text{ (silver required to react with developer)} \end{array}$$

$$\frac{12.50}{10} = 1.25 \text{ grams potassium bromide per liter}$$

Determination of Bromide in the Presence of Appreciable Quantities of Chloride.—As stated above, the adsorption method for bromide in developers is open to the objection that it measures total halide, and this method is applicable only when chlorides and iodides are known to be present in negligible quantities. It is rare that iodide is present in appreciable quantities, but chloride may be, either from the chemicals or from processing quantities of chloride emulsions in the developer. A method has been devised by the Kodak Research Laboratories which will measure bromides accurately in the presence of chlorides and thiocyanates, and it is given below. Iodides, however, will interfere if present in significant amount.

Reagents required:

1 Normal sodium hypochlorite

Phosphate solution: An aqueous solution containing 0.5 gram sodium dihydrogen phosphate monohydrate ($\text{NaH}_2\text{PO}_4 \cdot \text{H}_2\text{O}$) per ml.

Formate solution: An aqueous solution containing 0.5 gram sodium formate per ml.

Silver nitrate solution: Tenth-normal, 17 grams silver nitrate per liter.

Sodium chloride solution: Tenth-normal, 5.8 grams sodium chloride (reagent grade) per liter.

Ammonium molybdate solution: Half-normal, 22.1 grams C. P. ammonium heptamolybdate ($(\text{NH}_4)_6\text{Mo}_7\text{O}_{24} \cdot 4\text{H}_2\text{O}$) in 250 ml.

And 5 *N* nitric acid, 5 *N* hydrochloric acid, 95 per cent ethanol, *N*/100 sodium thiosulfate (standardized), sodium chloride (reagent grade), potassium iodide (iodate free), 5 per cent starch solution.

Procedure.—To a suitable sample in a 125-ml flask, add 1 ml *N*/10 sodium chloride, 10 ml 95% ethanol, 10 ml 5 *N* nitric acid (there should be no precipitate at this point), then 5 ml *N*/10 silver nitrate, shake well, and then filter through a fine paper in a Gooch crucible using suction to dry the precipitate. Wash the precipitate from the flask with alcohol. Transfer the paper and precipitate to a 500-ml flask using as little water as possible. Add 10 grams sodium chloride. Heat to boiling on a hot plate, adding a little water so as to dissolve most, but not all, of the sodium chloride. After boiling approximately $1\frac{1}{2}$ to 2 minutes add 2.0 ml phosphate solution, 10.0 ml hypochlorite solution, and heat, finally boiling. If necessary, add sufficient water, just to dissolve any solid sodium chloride. Boil at least 1 minute. Add 5 ml formate solution and cool to room temperature. Make the volume approximately 150 ml, add 1 gram potassium iodide, 20 ml 5 *N* hydrochloric acid, 1 drop of molybdate, and titrate immedi-

ately with 0.01 *N* thiosulfate, adding a few drops of starch solution near the end point. Run a blank on the reagents.

The blank may be of the order of 2 ml, and the sample should be chosen to give a thiosulfate value from 5 to 15 ml. This will require from 2 to 10 ml of developer, depending on the bromide concentration. The calculation is made from the following equation:

$$\frac{(\text{volume thiosulfate} - \text{blank}) \times \text{normality thiosulfate} \times 119}{\text{volume of sample} \times 6} = \text{grams potassium bromide per liter}$$

BORATES

Borax (sodium tetraborate, decahydrate) is commonly used as an alkali in negative developers. It is a relatively weak alkali, and its use makes it possible to balance the developer formula so as to obtain a slow rate of development and minimum graininess. Occasionally boric acid is used with borax in order to increase the buffer capacity of the developer.

Buffer Capacity.—The buffer capacity of a developer may be considered as its ability to withstand the addition of acid or alkali without changing its *pH*. It is possible to alter the buffer strength of developers by adjustment with the proper chemicals, and in a borax type developer the buffer capacity may be increased by the addition of borates, either as borax, boric acid, or both. The total quantity of borates present then determines the resistance of the developer to a change in *pH*. In other types of solutions other salts may act as buffers, for example, carbonate acts as a buffer in positive developers.

The buffer capacity of a developer is of photographic importance. For example, the aerial oxidation which occurs in all developing solutions exposed to the air causes the formation of free alkali. The photographic effect of this is not proportional to the quantity of alkali formed but to the resultant change in *pH*. Since the change in *pH* per unit change of alkali is a function of the buffer capacity of the developer, the buffer capacity actually controls the photographic effect. This has great practical significance in both picture and sound negative developers.

Qualitative Test for Borates.—Borax may be made from boric acid simply by the addition of caustic; borax is an alkali salt of boric acid. Thus the only distinction between the two is one of *pH*, and a qualitative test for borate ion will be positive in the presence of either borax or boric acid. Both substances are white crystals moderately soluble in water and glycerin.

To test for borates, a portion of the solution is acidified and tested with turmeric paper. If the paper turns red borate ion is present. Borates may also be detected by acidifying the solution with sulfuric acid, adding methyl alcohol, and igniting the vapor in a darkened room. A green color in the flame indicates the presence of borate. Copper and phosphoric acid interfere.

Quantitative Determination of Borates.—Borates may be present in a developer as borax or boric acid and it is impossible to distinguish between them in solution except in the manner indicated above to distinguish between sulfite and bisulfite. The determination of the total boron content may be made as follows:

The developing agents are extracted from a 100-ml portion of the developer by extraction in a separatory funnel. Three extractions are made, from a solution adjusted to a pH of 8.0, using 50 ml of ethyl ether for each extraction, shaking vigorously. The remaining solution is boiled to eliminate all the ether present and the solution acidified with hydrochloric acid and boiled to drive off sulfur dioxide and carbon dioxide. Since long-continued boiling is required to eliminate all traces of sulfurous acid the solution is treated with hydrogen peroxide to oxidize the last traces of sulfite to sulfate. The solution is then exactly neutralized with sodium hydroxide using brom cresol green as an indicator. One gram of mannitol, or 50 ml of pure glycerine, are now added and the solution titrated with 0.1 N sodium hydroxide using phenolphthalein as an indicator. On reaching the end point more mannitol or glycerine is added and the solution heated. If no change is produced the end point is permanent, but if the pink color fades more hydroxide is added until the further addition of glycerine produces no change in color. This titration is based on the fact that in the presence of glycerine or mannitol boric acid becomes a strong acid and can be titrated with sodium hydroxide. One mol of hydroxide is required for each mol of boron so that the following equations may be used for computing the borate content:

$$1 \text{ ml } 0.1 \text{ N NaOH} = 0.00953 \text{ gram Na}_2\text{B}_4\text{O}_7 \cdot 10\text{H}_2\text{O}$$

or

$$1 \text{ ml } 0.1 \text{ N NaOH} = 0.00618 \text{ gram H}_3\text{BO}_3$$

PHOSPHATE

Trisodium phosphate is occasionally used as the source of alkali in a developer. Its presence may be detected by acidifying a portion of the developer with nitric acid (avoid excess, but make sure the solu-

tion is acid). Add a solution of ammonium molybdate, heat, and a yellow precipitate of ammonium phosphomolybdate indicates phosphate. Halides may interfere and should be precipitated with silver nitrate and filtered off if present, or the reaction carried out in the presence of ammonium nitrate.

CITRATE

Citric acid is sometimes added to a developer, but if the solution is alkaline it is present as sodium citrate. The presence of the latter salt in solution does not enable an analyst to state whether it was added as the salt or the acid, so if it is present a fresh developer must be prepared according to the formula found, using sodium citrate, and the pH of the resulting solution compared with that of the unknown. Obviously if the pH of the original developer is lower than that of the prepared solution the citrate was added as citric acid and not as the salt. This method is also necessary to distinguish between borax and boric acid, between sulfite and bisulfite, and in all similar cases.

To detect citrate all the other acid groups must first be eliminated. Oxidize all the sulfite in a portion of the developer with peroxide or iodine. Acidify with hydrochloric acid and add barium chloride until no further precipitate forms. Filter, and after neutralizing the filtrate with sodium hydroxide add it to a solution of barium hydroxide. Make sure the solution is alkaline, but avoid excess caustic. In the absence of borates, tartrates, and organic acids in general a precipitate indicates the presence of citrate. However, if there are present any of these interfering substances the precipitate will have to be analyzed further. Filter and wash the precipitate well, transfer it to a beaker, add a little water, and dissolve the precipitate in hydrochloric acid, using the minimum necessary quantity of acid. Add just enough sulfuric acid to precipitate all the barium present, and filter. This leaves a solution of citric acid or other organic acids if any were present. There are also present small quantities of sulfuric and hydrochloric acid. Evaporate slowly until crystals begin to form in the solution, but not to dryness, decant the liquid, and recrystallize several times from distilled water. A melting-point determination is now made on the residue. Citric acid crystallizes with 1 mol. of water, which it loses at $130^{\circ}C$, and the acid melts at $153^{\circ}C$.

As stated above, borates and organic acids, such as tartaric, will interfere with this determination, but it is not likely that they will

all be found in an ordinary developer. Borates may be removed by acidifying the solution with sulfuric acid, adding methyl alcohol and distilling until the alcohol no longer burns with a green flame. Tartrates may be distinguished from citrates by adding a solution of the salt or acid to an ammoniacal solution of silver nitrate. Tartrates will reduce the silver to form a silver mirror while citrates will not.

GELATIN

Gelatin is present in all used developers. It exerts a slight retarding effect on the rate of development, and also combines with other substances in solution to form a sludge. Gelatin apparently exerts very little effect on the photographic properties of the solution, and for this reason it should not be necessary to make exact chemical determinations of the gelatin concentration.

pH

The activity of a developer is dependent primarily on the concentration of developing agents and the pH of the solution. Careful research^{16,17,18} has shown that the activity of a given developing agent is independent of the kind of alkali present and is solely dependent on the pH of the solution. This is true for elon and hydroquinone in the presence of borate, carbonate, and phosphate over the useful pH range for these developing agents. Hence for purposes of control or to determine whether a developer is up to standard, a determination of its pH may convey more information than the complete analysis of its anion constituents. In other words, if an ordinary studio developer is found to be less active than other developers prepared according to the same formula, a pH determination may avoid the necessity of a complete quantitative analysis, since if the developer does not have the correct pH the difficulty is at once located. Methods of determining the pH of solutions include the use of color indicators and various electrical devices of which the glass electrode appears to be the most satisfactory. Tests have shown that for very slight differences in pH the change in the photographic activity of a developer may be more significant than the slight changes in the color of the indicators produced by such changes in the pH. For larger differences in pH, however, of the order of half a pH unit, or greater, color indicators such as the LaMotte indicators are quite satisfactory for use with developers. For changes much less than half a pH unit a glass electrode should be used in connection with a high-grade potentiometer.

While pH is one of the most important factors governing the behavior of photographic solutions, it is not the only one, and therefore too much stress should not be placed on pH measurements alone. In practice it has been found that the pH value of a positive developer may stay quite constant, while the photographic properties of the bath may change either in the direction of greater or less activity. It is not at all true, as might be thought at first glance, that an exhausted bath will necessarily show a lower pH . It does not even follow that a higher pH will always show a more energetic developer. The successful application of pH measurements to developer control also requires a knowledge of the concentration of the developing agents, the sulfite and the bromide in the developer. When used in connection with these measurements a knowledge of the pH value should enable a chemist to maintain his developer quite uniformly.

This Laboratory makes use of a Beckman pH meter for use in determining the pH of processing solutions. This instrument has been found most satisfactory. Using ordinary care values can be repeated within ± 0.02 of a pH unit, and absolute values are apparently reliable to about the same degree. For pH values greater than 9.5 it is necessary to use a sodium ion correction in order to obtain absolute pH values. No direct method for the determination of sodium ion by itself is available. For control purposes in a processing laboratory it is probable that the sodium ion correction may be safely omitted and the observed pH used as a guide to the behavior of the solution. Experience with the positive developer of one release laboratory has indicated that the sodium ion concentration is virtually constant and that the fluctuations in corrected pH values correspond closely to those in the observed pH values. In picture negative and variable-density sound-track developers, where pH control is more vital than in positive type developers, no sodium ion correction is needed, since the pH is generally below 9.5. If it is desired to determine the pH of a developer having an observed pH greater than 9.5, it is the practice of this Laboratory to make a quantitative determination of sulfite, sulfate, and carbonate in the developer and to calculate the quantity of sodium ion present, assuming that it is all associated with these three ions.

TOTAL ALKALINITY

The determination of the total alkalinity of a developer is of little photographic significance, but it may be of some chemical value.

The work of Sheppard^{16,17} and Reinders and Beukers,¹⁸ as well as much practical experience, has shown that pH is the most significant factor in the alkalinity of a developer so far as its activity is concerned. However, from a chemical standpoint knowledge of the alkali concentration is useful, and its measurement provides a check on other chemical data obtained.

The measurement of total alkali concentration is ordinarily made by titration with a standard solution of a strong acid. In a solution as complex as a developer the proper choice of end point for the titration is not simple. If phenolphthalein is used as an indicator the measurement gives one-half the carbonate concentration and is not affected by the sulfite. This indicator will not give a suitable end point in the presence of borax and is not very satisfactory in any developer. If the end point is chosen at the neutral point of water ($pH = 7$), an indeterminate answer will be obtained since the end point will be in the middle of the buffer range of both carbonate and sulfite. In order to titrate to a point sufficiently acid to convert all the sulfite to sulfurous acid a very strong acid point must be reached, and the result will be inaccurate unless special precautions are taken.

A satisfactory compromise for this problem has been reached in this Laboratory by titrating to a pH of approximately 4.4 using the color change of brom cresol green from green to yellow. This end point is as sharp and well defined as any and occurs at a point between buffer ranges of the common developer constituents, so that a determinate result is obtained. At this point all carbonate or borate present is completely neutralized, and the sulfite is exactly half neutralized. A separate determination of the sulfite concentration will thus allow the carbonate concentration to be calculated from the total alkalinity. While this method is also theoretically correct for the determination of borax in a developer, the low ratio of borax to sulfite which prevails in most developers makes the method one of low precision. The presence of other weak acids, such as elon, hydroquinone, boric and citric acids, does not interfere in this calculation since they are largely converted to the undissociated state during the titration, and their net effect on the carbonate calculation is nil.

The procedure for measuring total alkalinity followed in this Laboratory is to titrate a 25.0-ml sample of the developer with 1.0 normal hydrochloric acid, using 1 ml of a 0.04 per cent solution of brom cresol green as an indicator. It must be remembered that the

results of this determination are not the absolute total alkalinity, but simply a convenient measure of part of it.

OTHER POSSIBILITIES

A number of additional substances are occasionally found in developers, for example, ammonia or ammonium salts, alcohol, formaldehyde, and substances used as desensitizers and dyes. Ammonia or ammonium salts may be detected by the odor from alkaline solution, or by heating an alkaline solution and testing the vapors with a piece of paper moistened with mercurous nitrate solution. Ammonia will blacken the test paper. Alcohol and formaldehyde and many other organic substances may be detected by their characteristic odors. If present they may be distilled from the developer solution and an analysis made of the distillate. Alcohol and other liquids are identified by their boiling points. Aldehydes are detected by their action with Schiff's Reagent. Desensitizers and dyes are generally present in very small concentration, and if not readily identified by color or other obvious characteristics, their identification is complicated and must be referred to an expert.

EXAMINATION OF A DEVELOPER FOR IMPURITIES

While impurities are not apt to be present in fresh developers, or in powders used in developers, developers are frequently submitted with complaints that satisfactory results are not obtained, and it is necessary to analyze the solution for substances which might cause trouble. The nature of the complaint determines the procedure to be followed, and useful methods for certain common complaints will be suggested. Obviously no attempt can be made to specify all the impurities which may be the source of a given difficulty. Three common complaints with used developers are:

- (1) Solution fails to develop, or develops too slowly.
- (2) The developer fogs badly.
- (3) The developer stains the film.

(1) *Developer Develops Too Slowly.*—The principal factors influencing the activity of a developer are developing agent concentration, the pH of the solution, and the bromide concentration. The pH of the developer should be compared directly with that of a fresh solution prepared according to the same formula. A slight difference in pH will cause a large change in activity in most developers. A

quantitative determination of the developing agents and bromide may be made according to the methods given above. These data, combined with a knowledge of the correct formula and its photographic properties, may enable the problem to be solved.

(2) *The Developer Fogs.*—Fog in a developer may be caused by a number of factors.¹⁹ Any developer will develop excessive fog if it is too strongly alkaline and has insufficient restrainer. The pH value should be checked and the bromide concentration determined. If these are satisfactory some impurity may be present. If the development process is carried out in such a manner that the film is exposed to the air during development, aerial fog may be found. This in turn may be due to the presence of certain compounds which appear to induce aerial fog, namely, copper, nickel, or formaldehyde. The latter substance is generally present only when it is specifically added, although it might be present as an impurity in alcohol if that substance is used. The metals must be analyzed for according to the following procedure:

The organic matter as well as weak inorganic acids must be eliminated from the developer. As much solution as can be spared, preferably 250 ml or more, is evaporated to dryness with nitric acid. The residue is dissolved in water, transferred to a casserole, made acid with nitric acid, and evaporated again. The residue is ignited to destroy any organic matter which remains. If borates are present it may be desirable to eliminate them by distilling with methyl alcohol. The residue is dissolved in water and analyzed for metallic constituents according to one of the standard procedures.¹⁰ Because of the fact that all of the salts are present as nitrates the addition of an excess of any strong acid to this solution will result in a considerable concentration of nitric acid. When treating the solution with hydrogen sulfide in analyzing for Groups II and IV this may result in the precipitation of free sulfur, and care should be taken that this is not confused with a metallic precipitate.

(3) *The Developer Stains the Film.*—A developer may stain film for any number of reasons.²⁰ Most frequently encountered are stains due to oxidized developing agents and stains due to traces of sulfide in the developer. An excessive accumulation of gelatin and sludge in the developer may also cause stain. Sometimes the oxidized developing agents are not in the developer, but in the fixing bath where they have been carried by the film, but this would only happen when the fixing bath is used for a great volume of work as in the recircu-

lated fixing baths used in some motion picture laboratories. This form of stain must be studied by actual film tests and chemical analysis will not help until more is known concerning the particular problem.

Sulfide in a developer will occasionally cause a yellow stain on film. The sulfide may be present in exceedingly small quantities and apparently acts as a catalyst in inducing the stain. Acidifying the developer and testing the evolved gases with potassium plumbite paper is the most sensitive test for sulfide. This paper is prepared by soaking filter paper in a solution made by adding a concentrated lead acetate solution to a concentrated solution of potassium hydroxide until no more dissolves.

ACCURACY OF QUANTITATIVE METHODS

In order to show the degree of accuracy which may be expected from a quantitative analysis of a developer an analysis was made on a solution compounded with accurately weighed ingredients. The compounds used in making up this developer were Eastman Tested Chemicals taken from their original containers with no additional treatment whatever. The chemicals used in the reagents were ordinary C. P. chemicals as supplied by J. T. Baker or other manufacturer of reagent chemicals. All weighings were made on a balance capable of measuring with an accuracy of ± 0.001 gram. Volumetric determinations were made using high-grade retested pipettes and burettes which were not calibrated. A limiting precision of approximately one-half per cent might be expected under such circumstances, whereas a higher precision would require the use of a more sensitive balance and of calibrated glassware. Inasmuch as most constituents of a developer may vary by ± 5 per cent without producing a significant difference in the photographic properties of the developer as determined sensitometrically, there is no point in attempting greater precision.

In addition to errors of method it must be borne in mind that chemicals used in preparing developers are not necessarily of C. P. grade and, in fact, are not generally that pure. Consequently accuracy of a high order is not to be expected, and great precision of measurement should not be attempted. This should not discourage the use of precise analytical methods in the study of developers which are compounded for that purpose, but is merely intended to save useless energy in analyzing ordinary commercial solutions.

The results of the analysis of a known developer solution are given in Table II. The figures given in the table are the result of a single determination.

TABLE II
Quantitative Analysis of a Known Developer

Developer Made up Containing Substance	Weight (grams)	Volume taken for Analysis (ml.)	Weight of Substance Found	Substance Calculated	Approximate Accuracy (per cent)
Elon	1.000	5.0	0.00493	0.00500	2
Hydroquinone	2.000	5.0	0.00993	0.0100	1
Sodium sulfite (desiccated)	25.00	11.8	0.274	0.295	1
Sodium sulfate	None	11.8	0.022	. . .	
Sodium carbonate (desiccated)	25.00	20.0	0.505	0.500	1
Borax (decahydrate)	5.00	100.0	0.530	0.500	6
Potassium bromide	1.000	100.0	0.101	0.100	1
Water to make	1.000 liter				

PART II

ANALYSIS OF FIXING BATHS

Whereas the analysis of developers is concerned with chemicals used in the reduction of exposed silver halides to metallic silver, the analysis of fixing baths deals with chemicals used to remove the undeveloped silver halide from the emulsion and to harden the emulsion so that it will dry rapidly and resist abrasions. The properties of fixing baths have been described by J. I. Crabtree and H. D. Russell.^{21,22}

Fixing baths do not ordinarily contain a great variety of substances, and in most instances the qualitative analysis of fixing baths is limited to examining unknown baths for a few specific compounds. If a bath is suspected to contain some additional compound a systematic analysis for metallic and acid radicals must be made according to some standard procedure.^{10,11,12} Methods will be given below for identifying and determining quantitatively the common constituents of a fixing bath:

Thiosulfate (hypo)
Sulfite
Acid Content
Acid Groups:
Acetate

Sulfate
Borate
Citrate
Tartrate
Potassium Alum
Chrome Alum
Silver
Ammonium Salts
Halides

From the commercial laboratory standpoint, it may be of primary interest to control the concentration of thiosulfate in the fixing bath for reasons of economy and to control the pH and alum concentration to obtain uniform hardening and drying properties. This may be done by means of the methods outlined below.

SODIUM THIOSULFATE

All ordinary fixing baths contain thiosulfate, commonly known as hypo, since it is the only simple compound which will readily dissolve the undeveloped silver halides. In the absence of sulfite, thiosulfate is detected by the bleaching of starch iodide blue. However, sulfite is generally added to fixing baths to prevent decomposition of the thiosulfate. Sulfite may be eliminated from solution by precipitation from neutral solution as calcium sulfite (calcium thiosulfate is soluble) or by the addition of excess formaldehyde. The latter substance reacts with sulfite in acid solution to form an undissociated compound which will not reduce iodine. Thiosulfate may also be distinguished from sulfite by the fact that the addition of a strong acid, such as sulfuric, will cause the precipitation of sulfur from thiosulfate, but not from sulfite. Sulfur dioxide will be evolved in either case. Minute quantities of thiosulfate can be detected by means of the sodium azide test. A few drops of unknown are placed in a test tube, or on a glass plate, and a drop of starch and iodine is added, then a drop of a 2 per cent solution of sodium azide. In the absence of sulfide and thiocyanate, bleaching of the blue color and the formation of gas bubbles indicate the presence of thiosulfate. This test is extremely sensitive and is said to detect as little as one part of thiosulfate in one million.

To determine thiosulfate quantitatively in the absence of sulfite, titrate the thiosulfate solution into 50 ml of tenth-normal iodine solution. The following reaction occurs: $2\text{Na}_2\text{S}_2\text{O}_3 + \text{I}_2 = 2\text{NaI} + \text{Na}_2\text{S}_4\text{O}_6$. When the brown color of the iodine is nearly bleached add

2 ml of starch solution and titrate slowly until the solution is colorless.

If sulfite is present it may be converted into a compound inert to iodine by adding excess formaldehyde and carrying out the titration in acid solution. Add 5 ml of formalin (formalin is a 40 per cent solution of formaldehyde in water) to a 2-ml sample of the fixing bath. Dilute to 200 ml with ice water, add acetic acid if necessary until the solution is acid, and titrate with tenth-normal iodine solution using starch as indicator. The solution should be kept as cold as possible. The quantity of thiosulfate is calculated according to the above reaction bearing in mind that the crystalline thiosulfate commonly sold commercially has the formula: $\text{Na}_2\text{S}_2\text{O}_3 \cdot 5\text{H}_2\text{O}$. In calculating the quantity of thiosulfate concentration, the following equation is used:

$$1 \text{ ml } 0.1 \text{ N I}_2 = 0.0248 \text{ gram Na}_2\text{S}_2\text{O}_3 \cdot 5\text{H}_2\text{O}$$

If a 2-ml sample of solution was taken,

$$1 \text{ ml } 0.1 \text{ N I}_2 = 12.4 \text{ grams per liter of thiosulfate}$$

SULFITE

If the above titration is repeated without formaldehyde the sulfite also reacts with iodine according to the equation:



The difference between the amount of iodine required in the titrations with and without formaldehyde represents the amount of sulfite present. The following equation may be used in calculating the sulfite concentration:

$$1 \text{ ml } 0.1 \text{ N I}_2 = 0.0063 \text{ gram Na}_2\text{SO}_3$$

If a 2-ml sample of solution was taken,

$$1 \text{ ml of } 0.1 \text{ N I}_2 = 3.15 \text{ grams per liter of sulfite}$$

The sulfite may have been added as the sodium salt, or as bisulfite. This can only be determined by comparing the pH of the unknown solution with that of a solution prepared from the formula determined by analysis, using sodium sulfite. If the prepared bath has a higher pH than the unknown, bisulfite should be tried.

ACID CONTENT

In fixing baths which also serve as hardening baths, some acid must be present in order to maintain the bath at such a pH value that it will harden the emulsion. If chrome alum is used as the hard-

ening agent the pH value must be maintained at 4.0 or lower.²¹ If potassium alum is used the pH must be 5.0 or lower, but if a boric acid bath is used, such as the Eastman *F-5* Fixing Bath,²² the bath will harden at any pH from 3.5 to 6.5. Sulfuric acid should be used with chrome alum baths and acetic acid is generally used with potassium alum baths. The acid may be added in the form of acid salts or as a liquid acid, or both. It is possible to determine by analysis only the total amount of each acid group present, the pH of the solution, and the total titratable acid. This information should be sufficient to specify the formula completely and it is certainly adequate to determine the photographic properties of the bath. For the latter purpose it is sufficient to know the pH value, which influences the rate of hardening, and the total acid, which determines the resistance of the bath to exhaustion by the addition of developer. For the control of circulating fixing baths, the total acid content should be neglected and pH measurements used altogether as a control.

The pH may be determined by the use of color indicators, such as the LaMotte indicators, or by the use of a glass or other electrode. The former method is adequate for colorless baths, but the latter apparatus is necessary for accurate measurements of chrome alum baths.

The total acid may be determined by titration with sodium hydroxide, but the proper choice of indicator is not simple. Since for photographic purposes the bath is useless above a certain pH value, depending on the hardening agent used, titration beyond this point is misleading from a photographic standpoint. The proper indicator in such cases may be brom cresol green, brom cresol purple, or brom thymol blue. In no case should the bath be titrated beyond the point where it begins to precipitate a sludge. Titration to an alkaline end point is difficult in the presence of alum or boric acid, and in the presence of chrome alum can only be done electrometrically.

ACETATE

The detection of the different acid groups will now be discussed. Acetate may be detected by the characteristic odor from acid solution. The odor of sulfur dioxide may be eliminated by precipitating the sulfite from alkaline solution with lead nitrate and acidifying with sulfuric or phosphoric acid. Acetates are usually determined by distilling acetic acid from a solution acidified with phosphoric acid.

In the presence of thiosulfate and sulfite this is not possible since sulfur dioxide will also be distilled.

The following procedure may be used to determine acetates in the presence of thiosulfate and sulfite. Mercuric chloride is added to a 50-ml sample of the fixing bath until no further precipitate forms. The precipitate is filtered off and the filtrate tested with iodine and starch to make sure no sulfite is present. Fifteen ml of syrupy phosphoric acid are added and the solution distilled until the residue is nearly dry. A Kjeldahl flask and condenser are suitable for this operation. The distillate is titrated with tenth-normal sodium hydroxide using phenolphthalein as an indicator. In calculating the acetic acid, the following equation may be used:

$$1 \text{ ml } 0.1 \text{ N NaOH} = 0.0060 \text{ gram glacial acetic acid}$$

SULFATE

Sulfate may be determined by precipitation with lead. The precipitation is carried out in neutral solution after removing aluminum or chromium by precipitation with ammonia. The sulfite, sulfate, and thiosulfate are all precipitated as the lead salt. The solution is filtered hot to prevent the precipitation of lead halide. The sulfite and thiosulfate are determined by titration with iodine as outlined above and the difference is calculated to determine the sulfate. An alternate method is the following:

Add excess formaldehyde to convert the sulfite to a compound which is inert to iodine and not precipitated by barium. Acetic acid is added until the solution is distinctly acid. A solution of potassium tri-iodide (KI_3) is added dropwise until a permanent yellow color is formed. This is bleached by adding a drop of dilute thiosulfate solution. The thiosulfate is thus oxidized to a compound soluble in the presence of barium. Barium chloride is added to precipitate the sulfate present which is filtered, dried, and weighed as barium sulfate. If chromium or aluminum is present the sulfate necessary to form an alum is calculated and the balance of the sulfate represents sulfate added as acid or other salt. The alum concentration may be computed from the weight of the barium sulfate precipitate by the following equation:

$$1 \text{ gram BaSO}_4 = 1.02 \text{ grams of potassium alum}$$

or

$$1 \text{ gram BaSO}_4 = 1.07 \text{ grams chromium alum}$$

BORIC ACID

Boric acid is added to fixing baths to improve their hardening and sludging properties. Its presence may be detected by turmeric paper which turns red in acid solution of borates. The color is intensified by drying the paper, and ammonia turns it blue. The quantitative determination of boric acid is complicated by the presence of other weak acids. It may be determined by distilling from acid solution with methyl alcohol, but volatile acids (sulfurous and acetic) should not be present. A simpler method is to remove the interfering acids as follows: Aluminum and chromium are precipitated with ammonia. The sulfur compounds are precipitated with mercuric chloride or lead nitrate. Acetic acid is removed by boiling it off from sulfuric acid solution. The solution is finally neutralized with sodium hydroxide using brom cresol green as an indicator. Glycerine or mannitol is added and the solution is then titrated with tenth-normal sodium hydroxide using phenolphthalein as an indicator (*cf.* Analysis of Borates in Developers, above). The boric acid concentration may be computed from the consumption of sodium hydroxide by means of the following equation:

$$1 \text{ ml } 0.1 \text{ N NaOH} = 0.00618 \text{ gram boric acid}$$

CITRIC AND TARTARIC ACIDS

Certain organic acids, for example, citric and tartaric, retard the formation of alum sludge in a fixing bath. For this reason they are sometimes added although the hardening properties of the bath are largely destroyed by the presence of these acids. Citric and tartaric acids are the only compounds of this kind commonly encountered and if present in a fixing bath may be detected as follows:

Aluminum and chromium are removed by filtration after precipitation with ammonia. Concentrated hydrochloric acid is added to decompose the thiosulfate into sulfur dioxide and sulfur. After boiling until the odor of sulfur dioxide is faint, filter and cool, add hydrogen peroxide or iodine until starch iodide paper shows that no sulfite remains. If boric acid interferes it may be removed by distilling with methyl alcohol until the alcohol no longer burns with a green flame. Acetic acid is added and just enough calcium chloride to precipitate whatever sulfate may be present. This is filtered off and the filtrate neutralized with sodium hydroxide free from carbonate. Cool thoroughly and add a few drops of calcium chloride solution. If a precipitate forms immediately it may be calcium tartrate.

Filter and examine the precipitate for tartrate. Dissolve the precipitate of calcium tartrate in a few drops of acetic acid and add to an ammoniacal solution of silver nitrate. Heat in a water bath and if a silver mirror is deposited tartrate is probably present. Citrates will not produce a mirror.

To the filtrate from the calcium tartrate solution add more calcium chloride and boil. If a precipitate forms on boiling, it may be calcium citrate. Calcium tartrate is precipitated from cold and calcium citrate from a hot solution. Examine the precipitate for citrate as outlined above for citrates in developers.

ALUM

The common alums used in fixing baths are potassium alum: $K_2SO_4 \cdot Al_2(SO_4)_3 \cdot 24H_2O$, and chrome alum: $K_2SO_4 \cdot Cr_2(SO_4)_3 \cdot 24H_2O$. They are readily distinguished since chrome alum solutions are always deep green or violet in color, while potassium alum solutions are always colorless. To detect their presence in a fixing bath chromium and aluminum are precipitated by adding a 6 normal solution of ammonia. The precipitate is filtered and washed with hot ammonium nitrate. If the precipitate is white, aluminum may be present and the aluminon test is applied. Dissolve the precipitate in 5 ml of normal hydrochloric acid, add 5 ml of 3 normal ammonium acetate and 5 ml of 0.1 per cent solution of ammonium aurin tricarboxylate (aluminon), shake and add ammonia until the solution is distinctly alkaline. A bright red flocculent precipitate indicates aluminum. The aluminum is determined quantitatively by precipitation with ammonia, filtering and washing with a hot ammonium nitrate solution, igniting and weighing as Al_2O_3 . The alum concentration is computed from the weight of the precipitate by means of the following equation:

$$1 \text{ gram } Al_2O_3 = 9.30 \text{ grams } K_2SO_4 \cdot Al_2(SO_4)_3 \cdot 24H_2O$$

If the ammonia precipitate is blue-gray, chromium may be present and is identified as follows:

Transfer the precipitate to a casserole, add 5 to 10 ml of 5 normal sodium hydroxide and 3 to 5 ml hydrogen peroxide, heat to boiling and keep near the boiling point for one to two minutes. The precipitate is dissolved and turns yellow if chromium is present. Filter if necessary and to one portion of the filtrate add 5 normal sulfuric acid until the solution is barely acid plus 1 to 2 ml excess, cool thoroughly,

and then add 1 ml of hydrogen peroxide. If chromium is present a blue color will appear and fade away. To the rest of the filtrate add acetic acid until the solution is distinctly acid, then add 1 to 2 ml of lead acetate solution. Yellow lead chromate will be precipitated if chromium is present.

Chromium is determined quantitatively in the same manner as aluminum, namely, by precipitation with ammonia, filtering, igniting, and weighing as Cr_2O_3 . The alum concentration is computed from the weight of the precipitate by means of the following equation:

$$1 \text{ gram } \text{Cr}_2\text{O}_3 = 6.57 \text{ grams } \text{K}_2\text{SO}_4 \cdot \text{Cr}_2(\text{SO}_4)_3 \cdot 24\text{H}_2\text{O}$$

SILVER

Silver is present in greater or less amounts in all used fixing baths and may be detected by precipitation with sodium sulfide. If chrome alum is present it should first be removed by precipitation with ammonia. The sulfide precipitate is dissolved in nitric acid, filtered, and the silver identified by precipitation with dilute hydrochloric acid. The important question with respect to silver in fixing baths is the concentration, and various means have been devised for determining this rapidly. If an argentometer is not available the silver is precipitated as the sulfide, dissolved in nitric acid, and titrated with thiocyanate using ferric alum as an indicator. If chromium is present it must first be removed by precipitation with ammonia as follows:

Six normal ammonia is added in slight excess and the solution boiled several minutes. The precipitate is filtered through paper on a Buchner funnel, and the filtrate treated with sodium sulfide until no further precipitate forms. This is then filtered *over the same filter paper* as before, and the precipitate washed. The paper and precipitate are transferred to a beaker and thoroughly digested with nitric acid. This solution is filtered to eliminate sulfur and paper pulp and the filtrate titrated with standard thiocyanate solution. Two or three drops of ferric alum solution are added as indicator and the titration is carried to a pink end point. The silver present may be computed by means of the following equations:

$$1 \text{ ml } 0.1 \text{ N KCNS} = 0.0108 \text{ gram Ag}$$

If desired the silver may be precipitated from the last filtrate with hydrochloric acid and weighed as silver chloride. The quantity of

silver may be computed from the weight of the precipitate by the following equation:

$$1 \text{ gram AgCl} = 0.753 \text{ gram Ag}$$

If no chromium is present the initial treatment with ammonia should not be necessary and the precipitation with sulfide is carried out directly.

AMMONIUM SALTS

Ammonium salts are occasionally added to fixing baths in order to increase the rate of fixation. They may be detected by adding sodium hydroxide until the solution is alkaline, heating and testing the vapors with paper saturated with mercurous nitrate solution. The paper will be blackened if ammonia is present. It is possible that if ammonium ion is present it is due to the use of ammonium alum rather than to an ammonium salt added to increase the rate of fixation. Ammonia may be determined quantitatively by distilling from alkaline solution into a saturated solution of boric acid. The ammonium borate is then titrated with hydrochloric acid to an end point with methyl orange. The quantity of ammonia may be calculated from the hydrochloric acid consumption by means of the following equation:

$$1 \text{ ml } 0.1 \text{ N HCl} = 0.0017 \text{ gram NH}_3$$

HALIDES

Halides are present in all used fixing baths. Since most insoluble halides are soluble in thiosulfate they are best separated by forming insoluble thiosulfates. A 50-ml portion of the bath is treated with ammonia until alkaline, boiled, and the precipitate filtered off. Mercuric nitrate, or lead nitrate, is then added in excess and the solution boiled and filtered. The filtrate is acidified with nitric acid and an excess of tenth-normal silver nitrate solution added. The solution is then titrated with standardized thiocyanate solution using ferric alum as an indicator. The calculation is the same as for halides in the developer (*cf.* above). If the fixing bath has been used for processing film the halide may be assumed to be all bromide except for the most exact determinations.

CONCLUSION

Suitable methods of analysis have been given in this paper for all the common photographic chemicals. They should enable a labora-

tory chemist to obtain any information which he may need for the successful operation and control of his processing solutions, and should aid him in placing his process on a sound technical and economic basis. The application of these methods to the problems of the motion picture laboratories will be continued by this Laboratory, and it is hoped that the work may be of benefit to the photographic industry.

We authors wish to express our appreciation to Mr. Emery Huse, at whose instigation this work was undertaken, and under whose guidance it was brought to completion.

The authors are indebted to Dr. Sheppard and Mr. A. Ballard for the method of determining bromide in the presence of chloride, and to Mr. R. M. Evans of the Kodak Research Laboratories for many helpful suggestions.

REFERENCES

¹ CLARKE, H. T.: "The Examination of Organic Developing Agents," *J. Ind. Eng. Chem.* (Nov., 1918); also *Brit. J. Phot.* (Nov., 1918), p. 499.

² ERMEN, W.: "Qualitative Tests for the Commoner Developers," *Brit. J. Phot.* (1917), p. 390.

³ PLAUMANN, H.: "Erkennung von Entwicklernsubstanzen," *Phot. Ind.* (1931), No. 29, p. 341.

⁴ LEHMANN, E., AND TAUSCH, E.: "Zum Chemismus der Metol-Hydrochinon entwicklung," *Photographische Korrespondent* (1935), No. 71, pp. 17 and 35.

⁵ TAUSCH, E.: "Zur Chemie der Photographischer Entwickler," Dissertation, *Der Technische Hochschule, Berlin* (1934).

⁶ EVANS, R. M.: "Maintenance of a Developer by Continuous Replenishment," *J. Soc. Mot. Pict. Eng.*, **XXXI** (Sept., 1938), p. 273.

⁷ EVANS, R. M., AND HANSON, W. T., JR.: "Chemical Analysis of an MQ Developer," *J. Soc. Mot. Pict. Eng.*, **XXXII** (March, 1939), p. 307.

⁸ EVANS, R. M., and Silberstein, G. P.: "Opacimeter Used in Chemical Analysis," *J. Soc. Mot. Pict. Eng.*, **XXXII** (March, 1939), p. 321.

⁹ BAUMBACH, H. L.: "The Chemical Analysis of Metol, Hydroquinone, and Bromide in a Photographic Developer," *J. Soc. Mot. Pict. Eng.*, **XXXIII** (Nov., 1939), p. 517.

¹⁰ PRESCOTT, A. B., AND JOHNSON, O. C.: "Qualitative Chemical Analysis," *John Wiley and Sons*, New York, N. Y. (1932).

¹¹ TREADWELL, F. P., AND HALL, W. T.: "Analytical Chemistry;" Vol. I: "Qualitative Analysis;" Vol. II: "Quantitative Analysis;" *John Wiley and Sons*, New York, N. Y.

¹² KAMM, OLIVER: "Qualitative Organic Analysis," *John Wiley and Sons*, New York, N. Y. (1932).

¹³ Association of Official Agricultural Chemists: "Analytical Methods," Washington, D. C.

¹⁴ BENEDETTI-PICHLER, A. A., AND SPIKES, W. F.: "The Microtechnique of Inorganic Qualitative Analysis," *Microchemical Service* (1935).

¹⁵ CHAMOT, E. M., AND MASON, C. W.: "Handbook of Chemical Microscopy," *John Wiley and Sons*, New York, N. Y. (1931).

¹⁶ SHEPPARD, "The Developing Equivalents of the Alkalies," *J. Chem. Soc.*, No. 89 (1906), p. 541.

¹⁷ SHEPPARD AND ANDERSON, *Brit. J. Phot.* (April, 1925).

¹⁸ REINDERS, W., AND BEUKERS, M. C. F.: "Der Einfluss des pH Wertes und der Konzentration des Reduktionsmittels auf das Entwicklungsvermögen eines Entwicklers," *Berichte über den VIII Int. Kond. Phot.*, Dresden (1931), p. 171.

¹⁹ DUNDON, M. L., AND CRABTREE, J. I.: "The Fogging Properties of Developers," *Trans. Soc. Mot. Pict. Eng.*, **XII**, No. 36 (1928), p. 1096.

²⁰ CRABTREE, J. I., AND DUNDON, M. L.: "The Staining Properties of Motion Picture Developers," *Trans. Soc. Mot. Pict. Eng.*, No. 25, p. 108.

²¹ CRABTREE, J. I., AND RUSSELL, H. D.: "Some Properties of Chrome Alum Stop Baths and Fixing Baths," Parts I and II, *J. Soc. Mot. Pict. Eng.*, **XIV** (May, 1930), p. 483 (June, 1930), p. 667.

²² RUSSELL, H. D., AND CRABTREE, J. I.: "An Improved Potassium Alum Fixing Bath Containing Boric Acid," *J. Soc. Mot. Pict. Eng.*, **XXI** (Aug., 1933), p. 137.

MOTION PICTURE THEATER DEVELOPMENTS*

M. RETTINGER**

Summary.—The first part of the paper is devoted to conveying basic requirements as well as recent developments in the design of motion picture theaters with balconies to provide satisfactory conditions for all the basic considerations of proper motion picture presentation.

The second part provides similar information pertaining to theaters with balconies. Separate sections are devoted to the dimensional and constructional features of balcony depth, soffit, and height; of the theater ceiling, sidewalls, and rear wall; and of the space above the balcony.

A recent survey by the Projection Committee of the Society of Motion Picture Engineers¹ brought to light several interesting facts regarding the visual and acoustic conditions of existing motion picture theaters. Probably the most striking result of this investigation consisted in the finding that of 600 representative houses examined only about 16 per cent proved to have satisfactory conditions for all the basic considerations of proper motion picture presentation. While this analysis included theaters built before the advent of sound, the number of satisfactory theaters erected since that time was not greatly larger, being in fact 27 per cent.

The following is intended to convey basic requirements as well as recent developments in the design of motion picture theaters. No mention of the type of theater wall construction shall be made, however, since the amount of sound insulation necessary to prevent extraneous noise from entering the house will depend on the specific local conditions. The theater without a balcony will be examined first, although parts of this discussion are applicable also to the theater with a balcony.

The high quality of air conditioning systems has brought about a considerable diminution in the number of cubic-feet of theater volume found required per person for proper comfort. A figure of 125 cubic-

* Presented at the 1940 Spring Meeting at Atlantic City, N. J.; received March 29, 1940.

** RCA Manufacturing Co., Hollywood, Calif.

feet has been suggested.² This is considerably less than found at present in the majority of houses and represents a material reduction in cost, not only so far as actual size of structure is concerned, but also in regard to the amount of necessary acoustic material, the power-handling capacity of the amplifier system and the magnitude and number of required loud speakers. Fig. 1 shows the variation of required electric power output of the reproducing system with the number of seats in the theater when allotting 125 cubic-feet of structural volume per spectator.

Regarding the proportions of height, width, and length of a house

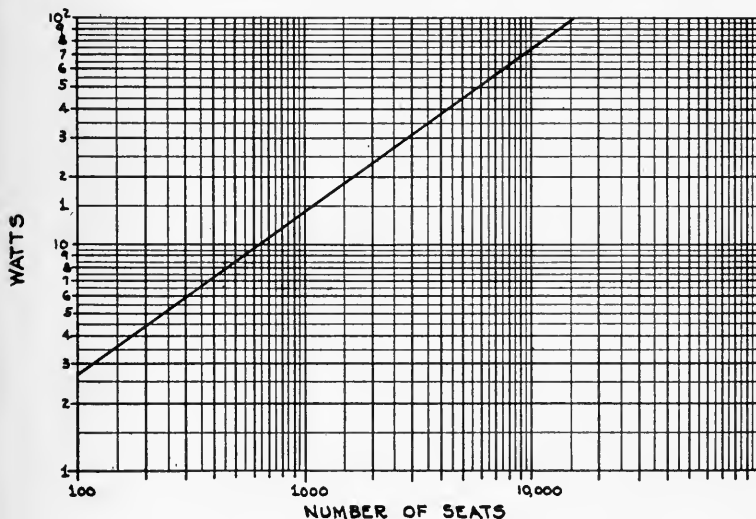

FIG. 1. Variation of required electric output with number of seats.

without a balcony, a value of 1:2.5:4.5 appears to provide a satisfactory relation in that the ceiling height is kept low.² A low ceiling not only materially reduces the volume of the auditorium, thereby effecting economy of construction, but also prevents "delayed reflections." A delayed reflection exists when the path difference between the reflected and direct sound is of the order of 60 feet or greater.

Knowing the proportions for the theater and the number of cubic-feet of volume per auditor, we may prepare the fundamental plan and elevation for the auditorium without balcony as shown in Fig. 2. The dimensions shown on these figures are derived as follows: Let-

ting x be the height of the ceiling in feet; $2.5x$, the width of the house, and $4.5x$ its length, we have:

$$x \cdot 2.5x \cdot 4.5x = 125N$$

where N is the number of spectators. Solving for x we get

$$x = 2.23 \sqrt[3]{N}$$

which represents the ceiling height. The width obviously is $2.5 \cdot 2.23 \sqrt[3]{N} = 5.57 \sqrt[3]{N}$, and the length $4.5 \cdot 2.23 \sqrt[3]{N} = 10 \sqrt[3]{N}$. Thus an auditorium planned to accommodate 1000 persons would have a ceiling height of 22.3 feet, a width of 55.7 feet, and a length of 100 feet.

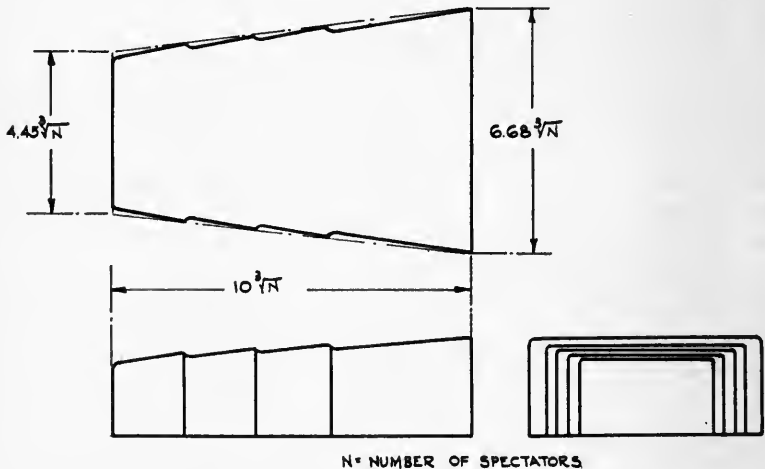

FIG. 2. Elevation and plan of auditorium without balcony.

Because plane parallel surfaces will give rise to flutter echoes unless such areas are treated acoustically, the sidewalls should be made to "fan out" toward the rear of the auditorium, and if possible should be provided with bold projections, corrugations, or pilasters. Likewise the ceiling surface should be broken up with sloping sections at proper inclinations to effect satisfactory dispersion and destination of reflections. Such treatment will do much toward providing a more uniform distribution of sound in the house, besides reducing the amount of acoustic material necessary to eliminate echoes. Ledges, rills, etc., may be superimposed on the larger projections. By themselves these smaller obstacles are effective only as scatterers for the higher fre-

quencies. It was shown early by Rayleigh³ that the amplitude of the reflected sound is directly proportional to the volume of the obstacles and the square of the frequency. Hence the size and depth of the projections should be made commensurate with the mid-range frequencies (500 to 1000 cycles) which carry the maximum peak power levels for conversational speech.⁴ In this connection it may be stated that it appears preferable to corrugate the sidewalls vertically (edges running from floor to ceiling) and not horizontally, so as to prevent delayed reflection. On the other hand, the rear wall if corrugated should have the corrugations orientated horizontally so as to provide sound reinforcement for the rear sections of the house.

Where excessive length of theater prevails, the rear wall also should receive acoustic treatment to prevent acoustic "hangovers" in the front and center sections of the building. Any calculations for the reverberation time in this case should be made carefully, however, preferably by a statistical method,⁵ since it can not be assumed that such an isolated sound-absorbing wall will make its normal contribution toward the reduction of reverberation throughout the larger part of the house. If this is not done, computed reverberation times are sure to be shorter than actually existing times.

The preferred recent type of construction of theaters, however, is the balcony house. Acoustically such an auditorium represents a more complex structure which should be carefully analyzed to prevent the acoustic defects observed in a number of such buildings. For a large audience it is practically the only desirable type of house in that it affords markedly better vision and intelligibility.

In designing a balcony house some computations of the sound level contour under the balcony should always be made. The sound level loss in db at any distance x under the balcony (origin at balcony opening) is⁶

$$\text{Loss} = 20 \log_{10} \left[\frac{1}{e^{-ax} + (1 - A_w)^{1/2} e^{-a(2L-x)}} \right] \quad (1)$$

where

- a = amplitude attenuation constant per foot
- $= \frac{A_s + A_f}{2(A_s + A_f + h)}$ (approximately, neglecting air absorption)
- A_s = absorptivity of balcony soffit
- A_f = absorptivity of under-balcony seating area
- A_w = absorptivity of under-balcony rear wall
- h = balcony height
- L = depth of balcony

For uniform sensation levels the value of I should not exceed 3 db.

It may now be in order to consider in detail the dimensions and the treatment of the various surfaces of a balcony house.

Balcony Height.—The balcony height, measured from soffit to seating height, bears a relation to the depth of the balcony, and should not be smaller than a third of that dimension, a half being preferred. When the soffit of the balcony is inclined toward the rear to act as a sound-reinforcing surface the height may be considered to be the average elevation of the soffit as measured from the seating level. For economic reasons, where the ceiling of the theater is kept low, the elevation of the balcony front may be one-half the ceiling height. Too small a balcony height, particularly where the depth of the balcony is considerable, produces an insufficient sound level below the balcony because of high reflection losses at the opening, besides inducing a low frequency resonance of objectionable character. Acoustic treatment of soffit to overcome this resonance will further lower the general sound level below the balcony, particularly at the rear seats, because the wave is now progressing between two absorbent surfaces, the other being the audience. Orientation of the loud speaker horn toward the under-balcony space to achieve a higher level therein obviously will curtail the sound volume in the region above the balcony besides probably flooding with sound the seating section close to the screen.

Balcony Depth.—The balcony depth, measured from the opening to the rear wall in a horizontal direction should not be more than three times, and preferably only twice, the height of the balcony (see *Balcony Height*). Considerable attenuation of sound occurs when this ratio is exceeded, the loss at the rear wall being

$$\text{db} = 6 - 8.6 aL \quad (2)$$

where a , as before, represents the amplitude attenuation constant per foot, and L the depth. Thus in the case of a soffit and rear wall made reflective to check this attenuation ($A_s \rightarrow 0$, $A_w \rightarrow 0$), and an occupied seating area ($A_f \rightarrow 1$), the amplitude attenuation constant comes to $1/(2 + 2h)$, and the loss is given by

$$\text{db} = 6 - \frac{8.6 \times L}{2 + 2h} \quad (3)$$

which in the case of a balcony depth of 30 feet and $L = 2h$ amounts to 2 db and for $L = 3h$ and $L = 4h$ comes to 5.7 db and 9.2 db, respec-

tively. These losses will, of course, be correspondingly larger when the soffit or the rear wall or both are treated acoustically. It should be noted that the above computations are valid only for mid-frequencies, since air absorption has been neglected in the formulas; for an accurate overall analysis including the attenuation of the upper registers, larger losses may be expected. It is well therefore to consider this problem carefully since at present the acoustic defects of balcony houses appear to consist mainly of inferior hearing conditions in the space under the balcony.

Balcony Soffit.—The soffit should slope toward the rear so as to present a sound-deflecting surface to the wave as it enters the under-balcony space. It should therefore not be treated acoustically. Non-treatment also will check undue attenuation of the sound-wave as it progresses along the under-balcony space, besides being instrumental in raising the reverberation time therein. It is well known that in such a coupled space the reverberation is not the same as in the seating area ahead of the balcony on the main floor or above the balcony, but usually has a noticeably lower value.⁷

The number of natural frequencies existing in the under-balcony space can not be reduced by slanting the soffit, except so far as such an obliquity may increase the under-balcony space, as the number of "eigentones" in any given frequency interval is chiefly a function of volume.⁸ However, by providing a large balcony opening, the resonance peaks can suffer such marked attenuation as to become practically unnoticeable.

Corrugating the soffit appears unnecessary because of the small amount of projected surface facing toward the screen.

Rear Wall.—The rear wall below the balcony, if the depth of the balcony is considerable, may remain untreated acoustically so as to allow sound reinforcement in the under-balcony space. However, where the depth of the balcony is no more than twice the height, acoustic treatment is justified. This will prevent the reflected sound-wave from reissuing into the main part of the auditorium where it may produce a so-called "hangover" or delayed reflection. Inclining the rear wall or providing it with corrugations also is advisable, as this will reduce the effect of standing waves during prolonged passages of music. A concave rear wall is never advisable, however, since a sound focus is one of the most objectionable defects with which an auditorium may be afflicted. Where a rockwool treatment of the rear wall can be draped with attractive tapestry, this is in order. Covering

rockwool treatment with a perforated hard material such as Masonite or asbestos board sometimes gives rise to high-frequency echoes which may be disturbing. An effective acoustic tile with a smooth and uniform absorption characteristic may be considered to constitute satisfactory treatment when its thickness and hence its absorptivity is chosen so as to meet the aforementioned requirements for minimum amplitude of the reflected sound-wave at the balcony opening.

Ceiling of Theater.—As in the house without a balcony, the ceiling height should be chosen low. This will obviate excessive acoustic treatment besides lowering construction costs and electric output requirements for the reproducing system. The use of sloping ceiling sections to exclude echoes and to secure desirably directed reflections is preferred. Again a concave ceiling contour, unless of a carefully studied parabolic nature, should be avoided. The effect of sound concentrations due to such curved surfaces can be only ameliorated by acoustic treatment; complete elimination usually involves expensive structural alterations of offending areas.

Where the auditorium has excessive volume, acoustic treatment of the ceiling is required to secure the necessary optimal reverberation times in the house. No detailed discussion of such treatment will be entered into here, however, since the subject is amply covered in literature dealing with optimal reverberation characteristics of theaters.⁹ Attention will be drawn only to an acoustic treatment which, if meeting quantitatively the requirements for a satisfactory reverberation characteristic in the auditorium, will cover not the entire ceiling but only its rear portions, so as to permit the utilization of the fore sections of the ceiling as an acoustic mirror for strengthening the sound levels in the seating area above the balcony. Architectural blending of treated and untreated ceiling surface is naturally in order. The esthetic aspects, however, here as elsewhere in this paper, will always be delegated to the architect.

Sidewalls.—As in the case of the theater without a balcony, plane parallel reflecting sidewalls should be avoided. Here, a fan-shaped cross-section for the plan appears more economical than slanting walls of the type used at the Salle Pleyel in Paris, for instance. Sidewalls can assist materially in maintaining the sound level uniform with respect to distance from the speakers, and indeed this should be made to be their principal function. Corrugations of sufficient depth to permit effective diffusion of the sound are always in order as a sidewall contour. Narrow beams, by themselves, nicknamed "harmonic

dispersers," have not been found to be of extensive value and do not constitute an economy item toward achieving high-quality sound reproduction in an enclosure.

Balcony Front.—The balcony front should be narrowly rounded so as to present the least amount of surface to the incident wave. A large flat front will result in an increased sound level directly ahead of

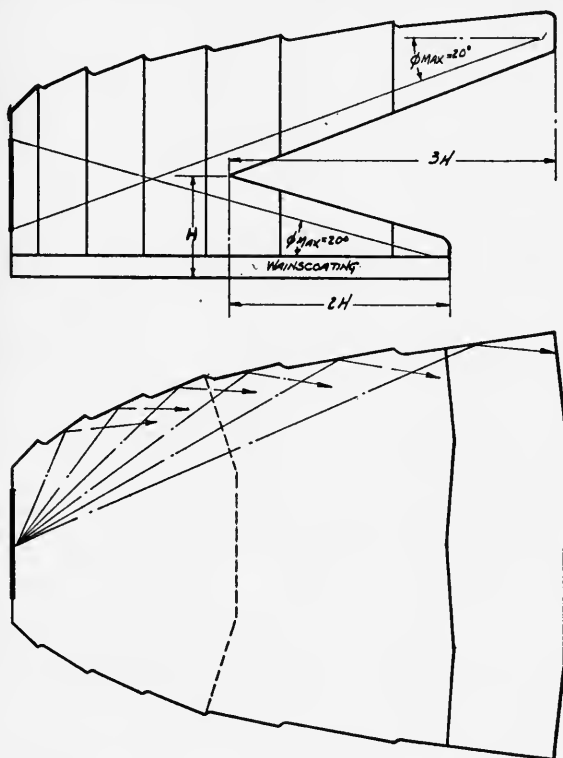

FIG. 3. Elevation and plan of theater of type discussed in the text.

the balcony on the main floor, an effect which can be only partly overcome by acoustically treating this facade.

Space above Balcony.—The depth of this portion of the theater, measured from balcony front to rear wall, may be larger than that below the balcony because a substantial portion of the ceiling reflections is directed thereinto. A value of 3:1 for the ratio of depth to balcony opening (distance from balcony front to ceiling) represents

suitable proportions for this space, particularly in the case where the balcony front occupies a mid-position in respect to ceiling height. The limit of the elevation for the very rear seat is given by an angle of 20 degrees subtended at that point by a horizontal and a line to the lower edge of the screen.¹⁰ The same limitations hold for the corresponding point below the balcony (Fig. 3).

Orientation of emitter horns should be such that the sound level in the above-balcony space is the same as that below. Where the RCA two-way speaker system is used (cross-over frequency, 250 or 300 cycles) this can be effected nicely and without the necessity of having to tilt the larger low-frequency horns, the sound from which is so nearly non-directional. Next to sound level measurements, however, listening tests above and below the balcony are always in order. It is only in this way that a pleasing balance between the upper and the lower register may be achieved. The ear should represent the final judge, as from it, in the words of Lord Rayleigh, "there can be no appeal."

Fig. 3 shows an elevation and plan for a theater of the type discussed. It is intended for an audience of 1000, with a volume content per person of 125 cubic-feet. While the backstage is not completed, being subject to specific purposes, it is assumed that a considerable amount of sound-absorptive material is prevailing therein to overcome any possible resonance phenomenon. The floor indicated has a slightly reversed slope in line with recent trend. Upholstered seats are suggested since they represent, when occupied, less variation in the total amount of sound absorption existing in the auditorium. Carpeted aisles also are in place, to reduce the disturbing effect of footfalls of incoming spectators.

REFERENCES

¹ Report of the Projection Practice Committee; *J. Soc. Mot. Pict. Eng.*, **XXX** (June, 1938), p. 636.

² POTWIN, C. C., AND SCHLANGER, B.: "Coördinating Acoustics and Architecture in the Design of the Motion Picture Theater," *J. Soc. Mot. Pict. Eng.*, **XXXII** (Feb., 1939), p. 156.

³ RAYLEIGH: "Theory of Sound," Vol. 2, p. 152.

⁴ PENDER, H., AND McILWAIN, K.: "Electrical Engineers Handbook," *John Wiley and Sons*, New York, N. Y. (1936), Acoustics Section (J. C. Steinberg), p. 9.

⁵ POWER, J. R.: "Measurement of Absorption in Rooms with Sound Absorbing Ceiling," *J. Acoust. Soc. Am.*, **10** (Oct., 1938), No. 2, p. 98.

⁶ MORISON, G. E.: "The Predetermination of Speech Levels in Auditoria with Coupled Spaces," *J. Acoust. Soc. Am.*, **9** (Jan., 1938), No. 3, p. 244.

⁷ EYRING, C. F.: "Reverberation Time of Coupled Spacer," *J. Acoust. Soc. Am.*, **3** (Oct., 1931), No. 2, p. 181.

⁸ BOLT, R. H.: "Frequency Distribution of Eigentones in a Three-Dimensional Continuum," *J. Acoust. Soc. Am.*, **10** (Jan., 1939), No. 3, p. 228.

⁹ MAXFIELD, J. P., AND FLANNAGAN, C.: "Wide-Range Reproduction in Theaters," *J. Soc. Mot. Pict. Eng.*, **26** (Jan., 1936), No. 1, p. 67.

WOLF, S. K., AND POTWIN, C. C.: "Recent Advances in the Acoustic Design of Motion Picture Theaters," *J. Soc. Mot. Pict. Eng.*, **26** (Oct., 1936), No. 4, p. 386.

BAGENAL, H., AND WOOD, A.: "Planning for Good Acoustics," *E. P. Dutton and Company*, New York.

¹⁰ SCHLANGER, B.: "The Motion Picture Theater Shape and Effective Visual Perception," *J. Soc. Mot. Pict. Eng.*, **26** (Feb., 1936), p. 128.

NEW MOTION PICTURE APPARATUS

During the Conventions of the Society, symposiums on new motion picture apparatus are held, in which various manufacturers of equipment describe and demonstrate their new products and developments. Some of this equipment is described in the following pages; the remainder will be published in subsequent issues of the Journal.

THE RESONOSCOPE*

S. K. WOLF AND L. B. HOLMES**

Since the beginning of music there has been a vital need for a device that will provide an accurate means of tuning musical instruments. As the science of music has progressed, this need has become more urgent. The "resonoscope" is one

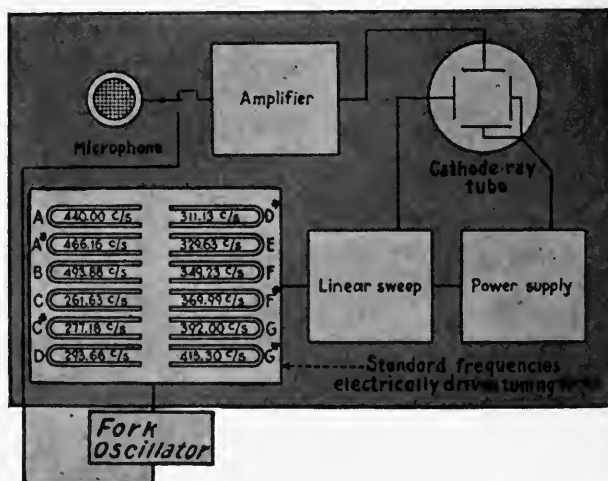

FIG. 1. Schematic diagram of the resonoscope.

answer to this demand and because of its simplicity of operation it is particularly useful to musicians and artists as well as to tuners and engineers. To those who are familiar with the design and function of cathode-ray tubes and cathode-ray oscillographs, the instrument will appear as a special application of the cathode-

* Presented at the 1938 Spring Meeting at Washington, D. C.

** Acoustic Consultants, Inc., New York, N. Y.

ray tube. However, much development was necessary before the device reached its present state of perfection.

The resonoscope consists of a special cathode-ray oscillograph, an instrument which records oscillations of electric currents, and a standard set of musical frequencies consisting of the twelve notes of the chromatic musical scale. These frequencies which are produced by twelve electrical tuning forks, are used to synchronize an oscillator which provides the horizontal sweep for the cathode-ray tube. A microphone and voltage amplifier picks up music or a single musical tone and the output of this amplifier is connected to the vertical plates of the cathode-

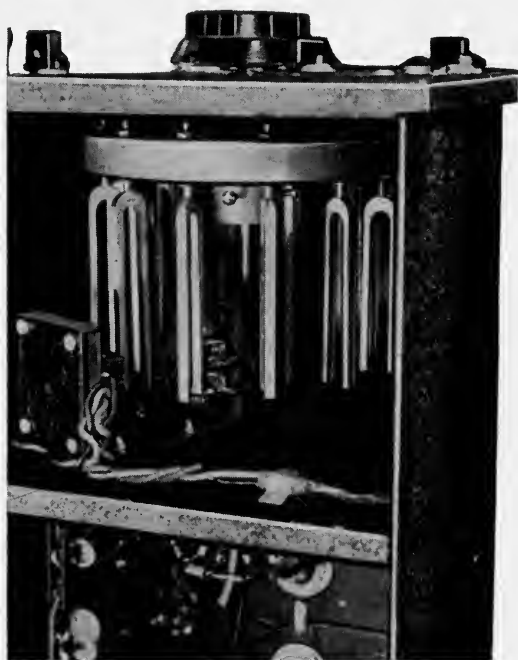

FIG. 2. Internal view of the tuning forks.

ray tube. Fig. 1 shows the arrangement of the various elements of the resonoscope.

This gives a visual picture of the wave-form of the music notes under observation. If the musical note is of the same pitch as the predetermined standard being used, or any harmonic of it, the wave will appear to stand still on the screen of the cathode-ray tube. If the note is flat, or lower in pitch than the horizontal sweep standard, the wave will appear to move to the left. If the note is higher in pitch, or sharp, the wave will move in the opposite direction. This indicates to the musician whether he is playing in tune, sharp, or flat. The speed with which the

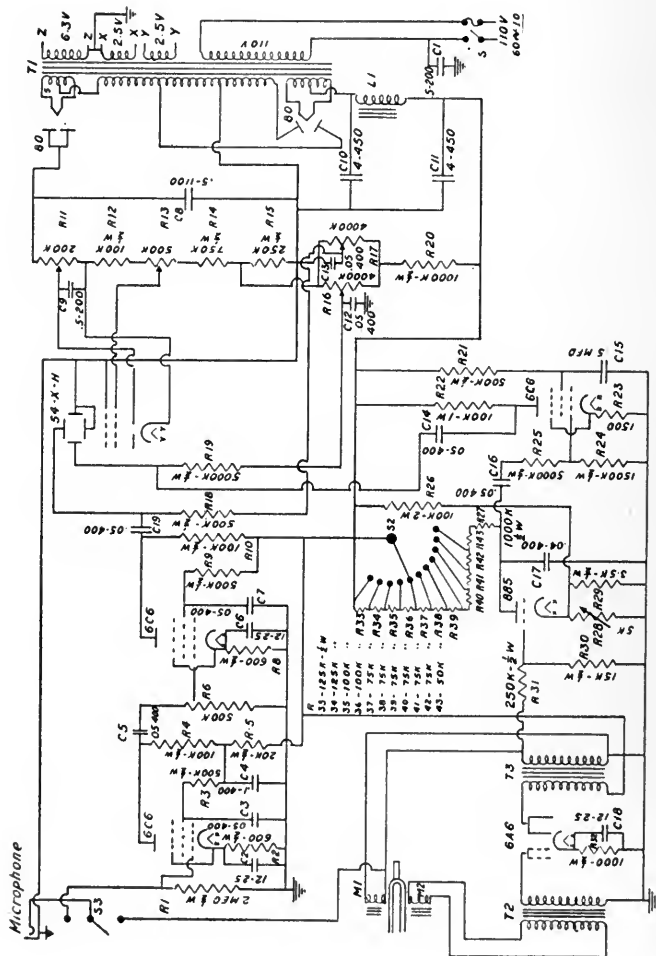

FIG. 3. Wiring diagram.

wave moves across the screen is a direct indication as to what extent the instrument is out of tune.

Any of the twelve standard frequencies used in the instrument may be selected, one at a time, by simply turning the control knob on the front of the panel to the frequency or note desired. These twelve frequencies represent the twelve notes of the scale and each setting of the control will accommodate all octaves of that particular note. Fig. 2 shows the arrangement and method of mounting the standard tuning forks in the instrument.

The resonoscope is so designed that the horizontal sweep circuit is automatically changed in frequency to compensate for the change in frequency in going from one

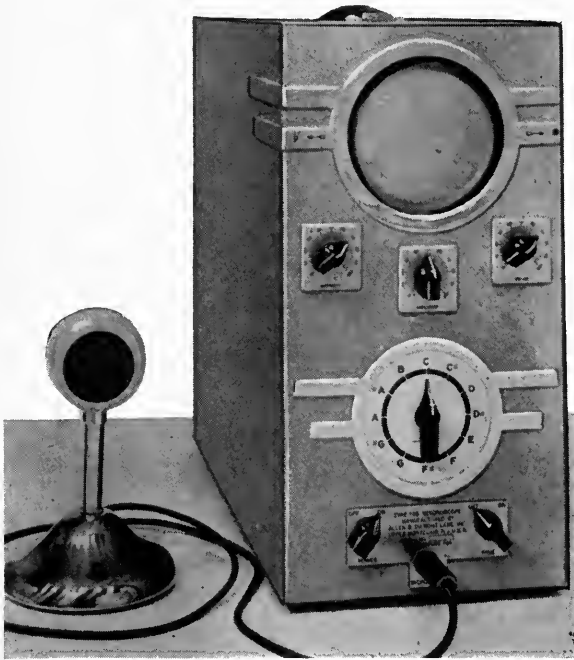

FIG. 4. The resonoscope.

note to another. This allows the sweep circuit to be easily synchronized at all times by the standard frequency of the tuning forks and assures the observer that the number of waves on the screen of the cathode-ray tube is a direct indication of the octave being played or tuned. The frequencies are calculated for the tempered scale, which is universally used for all types of tuning.

The pitch of the note *A* is 440 cycles per second, which is the most widely accepted pitch standard for tuning. Although 440 cycles per second is the frequency used in the standard resonoscope, any frequency may be substituted as desired. To provide a high degree of accuracy, a frequency counter or pitch standard was

installed in the DuMont Laboratories for testing the resonoscope in production. The tuning fork employed was checked at frequent intervals against the 440-cycle tone signal transmitted daily by the Bureau of Standards through station WWV. The tuning forks were electrically driven and their respective frequencies picked up electrically, amplified, and made available for any circuit. In the case of the frequency counter, the given standard frequency from the master tuning fork is caused to beat against an unknown frequency of a tuning fork or musical instrument under test. The beat note, or frequency difference, causes the dial of an electromagnetic counter to indicate the number of cycles of difference between the standard and the test tones in any given interval of time. The cathode-ray oscillograph provides a visual indication of the beat frequency and shows whether the test tone is sharp or flat with regard to the standard. The test tone is picked up electromagnetically in the case of the tuning fork, or by means of the microphone in the case of a musical instrument. The main purpose of the frequency counter is to check the resonoscope or cathode-ray musical pitch standard and comparators. The equipment is capable of counting down to one cycle difference per minute. Fig. 3 is a detailed wiring diagram of the complete instrument.

To the non-technical musician who has little or no interest in the theory and operation of the resonoscope, it suffices to say that the resonoscope is so constructed that any one can operate it and use it in tuning musical instruments about as simply as one can tune in a station on a radio receiver. The front of the instrument showing the cathode-ray tube and the controls is shown in Fig. 4.

The only other practical instrument the authors know of for determining pitch is a rather elaborate device which works on the stroboscopic principle, developed by C. G. Conn, Ltd. of Elkhart, Indiana, known as the "Chromatic Stroboscope." This device is also useful for tuning musical instruments and gives a visual indication as to what extent a note is sharp or flat.

Because the instrument makes the pitch "visual" as well as audible, it is extremely valuable in developing a more accurate sense of pitch, and makes it possible to determine the degree of sharpness or flatness. When used for voice analysis, the actual form of the voice waves reproduced on the viewing screen makes it possible to observe the harmonic content of the voice. If the student is adept in holding a note at constant pitch and amplitude, a photograph may be taken for further reference and study. The instrument also gives an indication of both the pitch and vibrato.

Manufacturers of musical instruments have found the resonoscope a useful aid in producing and testing their instruments. Manufacturers of string instruments can use the resonoscope to test the character of the string. For experimental purposes with musical instruments, pitch changes and variations in timber resulting from the use of various metals, constructions, shapes, and sizes can be observed with the instrument. It also provides a means of determining how well an instrument retains its pitch. The resonoscope has been used extensively in tuning and voicing the pipe organ, and, in the recording field, for measuring flutter in film, disk, and magnetic tape recording and reproducing equipment.

CURRENT LITERATURE OF INTEREST TO THE MOTION PICTURE ENGINEER

The editors present for convenient reference a list of articles dealing with subjects cognate to motion picture engineering published in a number of selected journals. Photostatic copies may be obtained from the Library of Congress, Washington, D. C., or from the New York Public Library, New York, N. Y. Micro copies of articles in magazines that are available may be obtained from the bibliofilm Service, Department of Agriculture, Washington, D. C.

British Journal of Photography

87 (January 19, 1940), No. 4159

Progress in Color (pp. 30-32)

87 (January 26, 1940), No. 4160

Progress in Color (pp. 39-41)

Communications

20 (February, 1940), No. 2

Television Economics, Pt. XIII (pp. 13-14, 46-49)

1940 Sound (pp. 17-20, 23, 27-32)

A. N. GOLDSMITH

S. GORDON TAYLOR

Educational Screen

19 (February, 1940), No. 2

A Study of the Comparative Effectiveness of Three Methods of Using Motion Pictures in Teaching, Pt. 1 (pp. 55-57, 74-77)

Motion Pictures—Not for Theaters, Pt. 16 (pp. 58-61)

J. E. HANSEN

A. E. KROWS

International Projectionist

15 (January, 1940), No. 1

Electronic Carbon Arc Control (pp. 7-8)

Technical Requisites for Commercial Television (pp. 10, 13, 14)

Projector Layout and Maintenance (pp. 15, 18)

G. W. SWITZER

J. FRANK, JR.

Report of the Projection Practice Committee of the SMPE

G. F. HOLLY

Portable Emergency Sound System (pp. 19-20)

New B. & L. Coated Lens Process Cuts Reflection and Boosts Light Transmission (pp. 21-22)

The Intermediate H.-I. Suprex Lamp: Design and Operating Data (pp. 23-24, 26-27)

E. W. MELSON

Kinotechnik

22 (January, 1940), No. 1

Prüfung der Askania-Stelier-Kamera durch die Deutsche Filmakademie (Testing of Askania Studio Camera by the Deutsche Filmakademie) (pp. 1-3)

R. THUN

Eine neue Klangfilm-Tonkopiermaschine zum Umkopieren von Normal-auf Schmalfilm und Umgekehrt (A New Klangfilm-Sound Printing Machine for Printing from Standard on 16-Mm Film and *vice versa*) (pp. 3-5)

A. HEINE

Verfahrensweisen zur Herstellung von Lackrohstoff aus Altfilmmaterial (Methods of Making Raw Material for Lacquer from Old Film) (pp. 5-7)

E. RADLOFF

Motion Picture Herald (Better Theaters Section)

138 (February 10, 1940), No. 6

Transmission of Light Increased with New Lenses (pp. 41-42)

High-Intensity D-C Lamp Designed for Small Theaters (p. 42)

The Photographic Journal

80 (February, 1940), No. 2

The Problem of Tone Reproduction Extended to Color Photography and Cinematography (pp. 25-37)

W. D. WRIGHT

HIGHLIGHTS OF THE CONVENTION

CHALFONTE-HADDEN HALL, ATLANTIC CITY, N. J., APRIL 22-25, 1940

Although the attendance at the Atlantic City Convention at Chalfonte-Haddon Hall, April 22 to 25th, inclusive, was not quite up to normal, it consisted almost 100 per cent of members who came with the sole intention of hearing the technical papers, as was indicated by the very full attendance at the technical sessions and the interesting and lengthy discussions which followed. On Monday and Tuesday the sessions ran until after midnight, and on Wednesday and Thursday until 6:00 P. M.

The total registered attendance was in the neighborhood of 150 persons; the attendance at the luncheon on Monday noon was about 120; and at the banquet on Wednesday evening, approximately 130.

The Convention opened on Monday morning under the chairmanship of President Williford, with reports of the Financial and Engineering Vice-Presidents and a brief welcome by Mr. Williford. After a report of the Studio Lighting Committee by E. C. Richardson, *Chairman*, which elicited considerable discussion on the activities of the studios, Dr. H. P. Gage presented a lecture on the various color theories and the specifications of color according to the standard Atlases of Color and the National Formulary sponsored by the American Pharmaceutical Association. Dr. Gage concluded his address with a description of the aims and functions of the Inter-Society Color Council.

The informal get-together luncheon was held in the Benjamin West Room of Haddon Hall, and the proceedings opened with a few words of welcome by President Williford and the introduction of Major W. T. Casey, who spoke in place of the Hon. Chas. D. White, Mayor of Atlantic City, who was unable to attend because of illness. Mr. Casey was followed by Mr. Thomas L. Hesselton, Secretary-Director of the Chamber of Commerce in Atlantic City. The principal speaker was Mr. Thomas F. Joyce, Vice-President of the RCA Manufacturing Co., Camden, N. J., who spoke on "The General Outlook for Television." Mr. Joyce's discussion centered principally about the possible applications of television and the way in which it could be woven into our general activities, and the many ways in which its uses were affiliated with the activities of the motion picture industry.

The afternoon of Monday, April 22nd, was devoted to a session of papers on sound, including a discussion of "The Control of Sound in Theaters and Preview Rooms," by C. C. Potwin, and a presentation by W. A. Mueller of an investigation of the influence of "Audience Noise as a Limitation to the Permissible Volume Range of Dialog in Sound Motion Pictures." Mr. Potwin's paper was concerned primarily with the design of theaters from the acoustical point of view prior to their construction, with the idea of rendering unnecessary many of the alterations and the installation of acoustical materials, after the construction of the theater,

in order to correct acoustical errors arising in the design of the theater. Mr. Mueller's paper, on the other hand, was concerned with the effect of the audience upon the possibility of obtaining adequate volume range in the recordings, pointing out that the lowest volume level practicable was determined by the audience noise which varied according to the moods of the audience. This likewise makes necessary a compression of the volume range which detracts from the dramatic value of the production.

On Monday evening, Dr. Matthew Luckiesh, Director of the Lighting Research Laboratory of the General Electric Company, Cleveland, Ohio, delivered a lecture on "The Science of Seeing." He covered rather broadly the many principles involved in acuity or vision and comfortable seeing, taking in such factors as brightness of the objects being viewed, contrast with neighboring objects, effect of the general environments of the objects, and the physiological and psychological influences affecting seeing.

The morning of Tuesday, April 23rd, opened with two papers on tone reproduction: Dr. L. A. Jones of the Eastman Kodak Company discussed "Photographic Tone Reproduction—Theory and Practice," and Mr. I. G. Maloff of RCA Manufacturing Company discussed tone reproduction in television. The session was concluded by a paper by Prof. E. H. Armstrong of Columbia University on "Frequency Modulation," in which Prof. Armstrong reviewed the development of the frequency modulation system and its possible effect and applications to modern radio transmission. Reference was made also to the possibility of using the system for the transmission to central motion picture recording studios of sound picked up on locations.

In the afternoon (April 23rd), Mr. J. A. Dubray, chairman of the Mid-West Section of the Society, acted as chairman of the 16-mm session. Papers by L. Thompson of the Calvin Company and J. F. Clemenger and F. C. Wood of Sound Masters, Inc., discussed direct 16-mm production and 16-mm equipment and practice. J. A. Maurer in a paper on commercial motion picture production with 16-mm equipment surveyed broadly the equipment, films, and services available for 16-mm production and presented a critical evaluation of the methods now in use. It was revealed that there is an increasing tendency to make negatives directly onto 16-mm film in the studio, which are then developed by reversal to positives. The duplicate negative is then made on fine-grain duplicating film and release prints then made by contact printing. A demonstration was made by projecting a 16-mm Kodachrome film onto a 14-ft. screen and the sound and picture quality was of such excellence as to be adequate for small theaters. The session was concluded by a paper by D. B. Joy and W. W. Lozier of the National Carbon Company, describing a new high-intensity carbon arc for the projection of 16-mm film.

Five interesting papers constituted the television symposium held on the evening of Tuesday, April 23rd. Mr. H. R. Lubcke of the Don Lee Broadcasting System described the television pick-up of the Pasadena Rose Tournament Parade, by means of the RCA portable television pick-up equipment later described by G. L. Beers, O. H. Schade, and R. E. Shelby. The latter equipment was demonstrated on the stage of the meeting room. In addition, W. C. Eddy of the National Broadcasting Company demonstrated some very novel remote control television lighting equipment used in the NBC television studios at New York.

An additional demonstration at the session was given by T. T. Goldsmith, R. L. Campbell, and S. W. Stanton of the DuMont Laboratories, of a new method of synchronization of television systems. Synchronizing standards were discussed that permit both flexible and automatic operation of television systems. P. C. Goldmark and J. N. Dyer discussed the question of quality of television pictures, with respect to artificial or "idealized" pictures produced by a scanning device designed for the purpose, which revealed that it is theoretically possible to obtain much better definition than is now being obtained with the 441-line images. Both morning and afternoon of April 24th were devoted to the problems of projection, under the chairmanship of Mr. H. Griffin. A noteworthy aspect of the projection sessions was the number of projectionists in attendance; and, despite the fact that the sessions were long, the attendance was good throughout the entire day. Mr. F. H. Richardson, in a comprehensive paper, traced the evolution of the projector from the original Thomas Armat machine to the present-day instruments. Of special interest was the paper by A. C. Downes, of the National Carbon Company, on gases from carbon arcs and their effects. The paper reviewed work done in various laboratories on the products of combustion from carbon arcs used in motion picture projection, presenting analyses of the gases coming from various lamps and showing that, even in the lamp house stacks, the only gas occurring in toxic concentration is nitrogen dioxide. Studies of ventilation under controlled conditions show that even with very low rates of renewal of the air in lamp houses and projection rooms, there is no danger of gases or fumes attaining toxic concentrations.

The paper by W. C. Kalb on "Progress in Projection Lighting" traced the improvement in the illumination provided by motion picture arc lamps for projection from the very early days of the arc to the present, showing a steady improvement with the development of successive types of arcs and lamp houses both as to the quantity of light delivered, the cost of carbon consumption, and other factors. Mr. C. S. Ashcraft described in considerable detail the "Cyclex" system of motion picture projection, which employs an alternating current arc with a shutter so arranged as to avoid the periodic "visual beat" generally occurring in alternating current projection systems. Other papers by T. P. Hover, B. Schlanger, and J. R. Prater discussed the general operation of the projection room and the work of the projectionists.

In a paper entitled "Speed Up Your Lens Systems," W. C. Miller of Paramount Studios described the effects resulting from the application of the new non-reflecting coatings applied to camera lenses. The reduction of reflections in optical systems so treated has been so great that ghosts and flares are now rarely encountered, as was demonstrated by a film produced with a camera employing treated lenses.

On the evening of Wednesday, April 24th, in the Rutland Room of Haddon Hall, was held the 46th Semi-Annual Banquet and Dance. The evening was devoted solely to dancing and entertainment.

On Thursday morning, April 25th, Messrs. E. W. Kellogg and R. O. Drew of RCA Manufacturing Company presented a discussion on "The Filtering Factors of the Magnetic Drive," supplemented by an interesting demonstration of a device designed to introduce into a sound recording "wows" of all various magni-

tudes and frequencies. The resulting wows were then measured by means of a "wowmeter."

Other interesting papers by J. G. Frayne, V. Pagliarulo, and G. R. Crane of Electrical Research Products, Inc., dealt with the effects of ultraviolet light on variable-density recording and printing, and the description of a precision integrating sphere densitometer. A paper by J. Robbins described a silent variable-speed treadmill used in the Paramount Studios in connection with process background photography. Constructional details, speeds, degrees of silence, and other factors were covered in the paper.

Mr. D. E. Hyndman presided over the concluding session of the convention, which opened with a description by C. E. Ires and E. W. Jenson of a number of improved devices for use in motion picture laboratories. G. R. Alburger presented a mathematical expression of developer behavior intended to unify the characteristics of developing agents in a mathematical way. The use of such analyses has been helpful in providing a guide toward modifying developers for producing given photographic characteristics. The new processing laboratory of Warner Bros. First National Studios at Burbank, Calif., was described in considerable detail by Messrs. G. M. Best and F. R. Gage.

A very comprehensive paper by R. B. Atkinson and V. C. Shaner of Eastman Kodak Company dealt in considerable detail with the chemical analyses of photographic developments and fixing baths, describing the identifying reactions of developing agents and their quantitative determination.

ACKNOWLEDGMENTS

The Society wishes to acknowledge its gratitude to the large number of persons and companies who collaborated in providing the various facilities for the convention. The general arrangements for the convention were made by Mr. W. C. Kunzman, *Convention Vice-President*; Mr. J. I. Crabtree, *Editorial Vice-President*; Mr. P. J. Larsen, *Chairman*, Atlantic Coast Section; Mr. H. Blumberg, *Chairman*, Local Arrangements Committee; Mr. Julius Haber, *Chairman*, Publicity Committee; Mr. M. C. Batsel, *Chairman*, Banquet Committee; Mr. S. Harris, *Chairman*, Papers Committee; and Mr. L. A. Aicholtz, *Chairman*, West Coast branch of the Papers Committee.

Thanks are due to Messrs. H. Griffin and M. C. Batsel for providing the projection equipment and public address systems used at the meetings. The Society extends its thanks also to Mrs. O. F. Neu, Hostess, and members of the Ladies' Committee, for their efforts in arranging an interesting program for the ladies attending the convention.

The Society is indebted also to the Wielland & Lewis Theaters, Inc., and to Warner Bros. Theaters, Inc., for the passes issued to the delegates to the Convention to the Apollo, Strand, Stanley and Virginia Theaters; and to Local 310 IATSE for providing the projectionist for the meetings.

PROGRAM OF THE ATLANTIC CITY CONVENTION*

MONDAY, APRIL 22nd

- 10:00 a.m. General and Business Session; E. A. Williford, *Chairman.***
Report of the Convention Arrangements Committee; W. C. Kunzmann, *Chairman.*
Report of the Financial Vice-President; A. S. Dickinson.
Report of the Engineering Vice-President; D. E. Hyndman.
Welcome by the President; E. A. Williford.
Society Business.
Report of the Studio Lighting Committee; E. C. Richardson, *Chairman.*
"Color Theories and the Inter-Society Color Council;" H. P. Gage, Corning Glass Works, Corning, N. Y. (*Demonstration.*)
Report of the Progress Committee; J. G. Frayne, *Chairman.*
- 12:30 p.m. Informal Get-Together Luncheon; E. A. Williford, *Chairman.***
Address of Welcome by the Honorable Charles D. White, Mayor of Atlantic City.
Guest: Mr. Thomas L. Husselton, Secretary-Director of the Chamber of Commerce of Atlantic City.
Speaker: T. F. Joyce, RCA Manufacturing Co., Camden, N. J., "The General Outlook for Television."
Greetings from the SMPE Pacific Coast Section; L. L. Ryder, *Chairman.*
- 2:00 p.m. Sound Session; L. L. Ryder, *Chairman.***
"The Control of Sound in Theaters and Preview Rooms;" C. C. Potwin, Electrical Research Products, Inc., New York, N. Y.
"Current Practices in Blooping Sound-Films;" W. H. Offenhauser, The Berndt-Maurer Corp., New York, N. Y.
"Investigation of the Influence of the Negative and Positive Materials on Ground-Noise;" O. Sandvik and W. K. Grimwood, Eastman Kodak Co., Rochester, N. Y.
"Recording and Reproducing Square Waves;" D. R. Canady, Canady Sound Appliance Co., Cleveland, Ohio.
"Audience Noise as a Limitation to the Permissible Volume Range of Dialog in Sound Motion Pictures;" W. A. Mueller, Warner Bros. First National Studios, Burbank, Calif.
- 8:00 p.m. Lecture; J. I. Crabtree, *Chairman.***
"The Science of Seeing;" Matthew Luckiesh, Director, Lighting Research Laboratory, General Electric Co., Cleveland, Ohio.

* As actually followed in the sessions.

TUESDAY, APRIL 23rd

9:30 a.m. **General Session; E. A. Williford, *Chairman*.**

- "Photographic Tone Reproduction—Theory and Practice;" L. A. Jones, Eastman Kodak Co., Rochester, N. Y.
- "Tone Reproduction in Television;" I. G. Maloff, RCA Manufacturing Co., Camden, N. J.
- "Frequency Modulation;" E. H. Armstrong, Columbia University, New York, N. Y.

2:00 p.m. **Sixteen-Mm Session; J. A. Dubray, *Chairman*.**

- "Direct 16-Mm Production;" L. Thompson, The Calvin Co., Kansas City, Mo. (*Demonstration*.)
- "Commercial Motion Picture Production with 16-Mm Equipment;" J. A. Maurer, The Berndt-Maurer Corp., New York, N. Y. (*Demonstration*.)
- "Professional 16-Mm Recording Equipment;" D. R. Canady, Canady Sound Appliance Co., Cleveland, Ohio. (*Demonstration*.)
- "Sixteen-Mm Equipment and Practice in Commercial Film Production;" J. F. Clemenger and F. C. Wood, Sound Masters, Inc., New York, N. Y. (*Demonstration*.)
- "A High-Intensity Carbon Arc for Projection of 16-Mm Film;" D. B. Joy and W. W. Lozier, National Carbon Co., Fostoria, Ohio.

8:00 p.m. **Television Session; A. N. Goldsmith, *Chairman*.**

- "Television Pick-up of the Pasadena Rose Tournament Parade;" H. R. Lubcke, Don Lee Broadcasting System, Los Angeles, Calif.
- "Quality in Television Pictures;" P. C. Goldmark and J. N. Dyer, Columbia Broadcasting System, New York, N. Y.
- "A New Method of Synchronization for Television Systems;" T. T. Goldsmith, R. L. Campbell, and S. W. Stanton, Allen B. DuMont Laboratories, Passaic, N. J. (*Demonstration*.)
- "Remote Control Television Lighting;" W. C. Eddy, National Broadcasting Co., New York, N. Y. (*Demonstration*.)
- "RCA Portable Television Pick-up Equipment;" G. L. Beers, RCA Manufacturing Co., Camden N. J.; O. H. Schade, RCA Radiotron Corp., Harrison, N. J.; and R. E. Shelby, National Broadcasting Co., New York, N. Y. (*Demonstration*.)

WEDNESDAY, APRIL 24th

9:30 a.m. **Projection Session; H. Griffin, *Chairman*.**

- "Advancement in Projection Practice;" F. H. Richardson, Quigley Publishing Co., New York, N. Y.
- "A Personal Safety Factor for Projection Practice;" T. P. Hover, Lima, Ohio.
- "New Lenses for Motion Picture Projection;" W. B. Rayton, Bausch & Lomb Optical Co., Rochester, N. Y.

- "Projection Supervision, Its Problems and Its Importance;"
H. Rubin, Paramount Theaters Service Corp., New York, N. Y.
"The Projectionist's Interest in Auditorium Viewing Conditions;"
B. Schlanger, New York, N. Y.
"Speed Up Your Lens Systems;" W. C. Miller, Paramount Pictures,
Inc., Hollywood, Calif. (*Demonstration.*)

2:30 p.m. Projection Session; H. Griffin, Chairman.

- "Gases From Carbon Arcs and Their Effects;" A. C. Downes,
National Carbon Co., Cleveland, Ohio.
"A New Negative Carbon for Low-Amperage High-Intensity
Arcs;" D. B. Joy, W. W. Lozier, and R. W. Simon, National
Carbon Co., Fostoria, Ohio.
"The Cyclex System of Motion Picture Projection;" C. S. Ashcraft,
Ashcraft Manufacturing Co., Long Island City, N. Y.
"Progress in Projection Lighting;" W. C. Kalb, National Carbon
Co., Cleveland, Ohio.
"Records for the Projection Room;" J. R. Prater, Palouse, Wash.

**7:30 p.m. Forty-Sixth Semi-Annual Banquet and Dance. Dancing and
Entertainment.**

THURSDAY, APRIL 25th

9:30 a.m. General Session; J. A. Maurer, Chairman.

- "Silent Variable-Speed Treadmill;" J. Robbins, Paramount Pic-
tures, Inc., Hollywood, Calif.
"Filtering Factors of the Magnetic Drive;" E. W. Kellogg and R.
O. Drew, RCA Manufacturing Co., Camden, N. J. (*Demon-
stration.*)
"The Effects of Ultraviolet Light on Variable-Density Recording
and Printing;" J. G. Frayne and V. Pagliarulo, Electrical Research
Products, Inc., Hollywood, Calif.
"Precision Integrating Sphere Densitometer;" J. G. Frayne and
G. R. Crane, Electrical Research Products, Inc., Hollywood, Calif.

2:00 p.m. General Session; D. E. Hyndman, Chairman.

- "Improvements in Motion Picture Laboratory Apparatus;" C. E.
Ives and E. W. Jenson, Eastman Kodak Co., Rochester, N. Y.
"Mathematical Expression of Developer Behavior;" J. R. Alburger,
RCA Manufacturing Co., Camden, N. J.
"Optimum Load Impedance for Feedback Amplifier;" B. F. Miller,
Warner Bros. First National Studios, Burbank, Calif.
"A Modern Studio Laboratory;" G. M. Best and F. R. Gage,
Warner Bros. First National Studios, Burbank, Calif.
"Chemical Analysis of Photographic Developers and Fixing Baths;"
R. B. Atkinson and V. C. Shaner, Eastman Kodak Co., Holly-
wood, Calif.
"Motion Picture Theater Developments;" M. Rettinger, RCA
Manufacturing Co., Hollywood, Calif.

Adjournment of the Convention.

SOCIETY ANNOUNCEMENTS

ATLANTIC COAST SECTION

At a meeting held at the Hotel Pennsylvania, New York, on April 17th, Dr. S. J. Begun of the Brush Development Company, Cleveland, presented a paper entitled "Some Aspects of Disk and Tape Recording." A demonstration was given of recording on disk, recording on magnetic tape, re-recording from the magnetic tape to the disk, and direct play-back from disk and tape.

The meeting was exceptionally well attended and considerable discussion followed the presentation.

MID-WEST SECTION

At a meeting held in the meeting rooms of the Western Society of Engineers, Chicago, on April 30th, Mr. M. Townsley of the Bell & Howell Company, Chicago, presented a talk on the "Elementary Theory and History of Lens Surface Treatment." This subject, of much importance at the present time, attracted a large attendance to the meeting and aroused an interesting discussion.

Concluding the meeting, Mr. J. A. Dubray, Chairman, reported to the Section on the Semi-Annual Convention of the Society just concluded at Atlantic City.

PACIFIC COAST SECTION

Mr. F. M. Falge of the General Electric Company presented a talk on fluorescent lamps at a meeting of the Section held at the Hollywood Chamber of Commerce Building, Hollywood, on April 8th. The paper discussed the general subject of fluorescent lamps, the color temperature problem, and the new line of 3200°K lamps, reflector lamps, including the *R-2* photofloods, the 250-watt *R-40* drying lamps, and mercury lamps for film processing applications. The various lamps described in the paper were displayed and demonstrated.

Mr. E. H. Reichard of Consolidated Film Industries, Inc., discussed production printing with mercury vapor lamps, and the application and control of the 85-watt *H-3X* high-intensity mercury vapor lamp as a printing light-source in the Consolidated automatic production printers.

Mr. F. L. Eich of the Paramount Laboratories discussed the use of mercury arcs for laboratory printing of release prints, and special copies on fine grain film stock.

Mr. J. K. Hilliard of the M-G-M Studios presented a talk on the use of mercury arcs for exposing fine-grain films in the process of sound recording.

NOMINATING COMMITTEE

A recent amendment of the by-law relating to the nomination of officers provided for the establishment of a Nominating Committee to make recommendations to the Board of Governors.

The Nominating Committee for the current year is composed, as follows:

	L. A. JONES, <i>Chairman</i>	
A. S. DICKINSON	H. W. REMERSCHIED	T. E. SHEA
G. FRIEDL, JR.	E. C. RICHARDSON	H. G. TASKER
D. E. HYNDMAN		E. A. WILLIFORD

To assist the Nominating Committee in its work, members of the Society are requested to forward to Dr. Jones, care of the general office of the Society, any suggestions they may have as to possible nominees for office for 1941. As the Committee is to report to the Board at the July meeting, suggestions should be mailed promptly.

Officers and governors whose terms expire December 31, 1940, are as follows:

E. A. WILLIFORD, <i>President</i>
N. LEVINSON, <i>Executive Vice-President</i>
J. I. CRABTREE, <i>Editorial Vice-President</i>
W. C. KUNZMANN, <i>Convention Vice-President</i>
J. FRANK, JR., <i>Secretary</i>
R. O. STROCK, <i>Treasurer</i>
M. C. BATSEL, <i>Governor</i>
H. G. TASKER, <i>Governor</i>

The Secretary and Treasurer hold office for one year, the others for two years.

ADMISSIONS COMMITTEE

At a recent meeting of the Admissions Committee at the General Office of the Society, the following applicants for membership were admitted to the Associate grade:

ARTHUR, J. C. 1634 Bergen Boulevard, Fort Lee, N. J.	GOSHAY, D. C. 2620 N. Beachwood Dr., Hollywood, Calif.
COLE, C. E. 70 Lincoln Ave., Grantwood, N. J.	HARE, M. M. 212 East 49th St., New York, N. Y.
COSTELLO, G. E. RCA Manufacturing Co., 411 Fifth Ave., New York, N. Y.	HAYNES, N. M. Amplifier Co. of America, 17 West 20th St., New York, N. Y.
DOVSON, J. L. 301—2nd Ave., No. 6, Salt Lake City, Utah.	HERBERT, H. W. 485 Fifth Ave., New York, N. Y.
DUNN, E. H. 104 Indian Rd., Port Chester, N. Y.	HILD, G. E. 828 West Grand St., Elizabeth, N. J.
GOLDSMITH, L. T. 3272 Lowry Rd., Los Angeles, Calif.	HUFF, F. W. 8712—31st Ave., Jackson Heights, L. I., N. Y.

- HUMM, W. E.
420 Ridgeway Ave.,
Rochester, N. Y.
- LARSON, C. O.
8251 Park Circle,
Inglewood, Calif.
- LOLLIOT, H. C.
c/o Philippine Engineering Corp.,
Manila, P. I.
- LUEDERS, W.
2212 Sunnyside Ave.,
Chicago, Ill.
- MARTIN, W.
1615 Maple St.,
Fort Lee, N. J.
- MESENKOP, L. H.
5451 Marathon St.,
Los Angeles, Calif.
- MUNHALL, D. J.
1810 Clark Bldg.,
Pittsburgh, Pa.
- NELSON, H.
220 Eagle Ave.,
Lakeview,
Hempstead, L. I., N. Y.
- NEUMANN, M. V.
10347 Rosbury Pl.,
Los Angeles, Calif.
- PETERSON, W. A.
16226 Cantlay St.,
Van Nuys, Calif.
- RASKIN, A.
855 Broad Ave.,
Ridgefield, N. J.
- REICHARD, A. E.
129 Bostwick Ave.,
Jersey City, N. J.
- ROCHE, J. E.
610 East 138th St.,
Bronx, N. Y.
- SCHMID, F. C.
Electrical Research Products, Inc.,
195 Broadway,
New York, N. Y.
- SIMONTON, R. C.
1910 Rimpau Blvd.,
Los Angeles, Calif.
- TAGUTI, R.
The Institute of Physical and
Chemical Research,
31 Kami-huzimae-tyo,
Hongo, Tokyo, Nippon.
- THOMPSON, W. S.
1016 N. Sycamore Ave.,
Los Angeles, Calif.
- TRIPP, C. A.
The Rochester Athenaeum and
Mechanics Institute,
Rochester, N. Y.
- WILKINSON, J. R.
7035 Lanewood Ave.,
Hollywood, Calif.
- YOUNG, H. M.
1576 Mineral Spring Rd.,
Reading, Pa.

In addition, the following applicants have been admitted by vote of the Board of Governors to the Active grade:

- CAMPBELL, R. L.
244 Walter Ave.,
Hasbrouck Heights, N. J.
- CUNNINGHAM, T. B.
c/o Electrical Research Products,
Inc.,
6601 Romaine St.,
Hollywood, Calif.
- DUMONT, A. B.
9 Bradford Way,
Upper Montclair, N. J.
- DYER, J. N.
485 Madison Ave.,
New York, N. Y.
- FARNSWORTH, L. L.
Eastman Kodak Co.,
185 Yuen Ming Yuen Rd.,
Shanghai, China.
- GOLDSMITH, T. T., Jr.
2 Main Ave.,
Passaic, N. J.

LORANCE, G. T.
Hamilton Rd.,
Chappaqua, N. Y.

SCOVILLE, R. R.
6601 Romaine St.,
Los Angeles, Calif.

WILLIAMS, F.
8111 Santa Monica Blvd.,
Los Angeles, Calif.

TEMPLIN, E. W.
6601 Romaine St.,
Los Angeles, Calif.

WALKER, R. O.
92 Gold St.,
New York, N. Y.

REPORT OF THE TREASURER FOR 1939

Balance, Jan. 1, 1939 \$24,223.86

Receipts during 1939

Membership dues	\$14,708.16
Sustaining Membership	4,500.00
Publication (Journal sales, reprints, subscriptions, advertising, etc.)	4,806.88
Other Income (membership certifi- cates, Journal binders, test-films, interest, etc.)	2,149.11
Total	\$26,164.15

Disbursements during 1939

Publication (Journal, reprints, binders, etc.)	10,752.70
Office expenses, salaries	11,498.65
Officers' expenses	927.13
Local Sections	795.92
Other expenses (dues and fees, test- films, misc.)	2,384.23
	\$26,358.63
	194.48

Balance, December 31, 1939

\$24,029.38

R. O. STROCK, *Treasurer*

S. M. P. E. TEST-FILMS



These films have been prepared under the supervision of the Projection Practice Committee of the Society of Motion Picture Engineers, and are designed to be used in theaters, review rooms, exchanges, laboratories, factories, and the like for testing the performance of projectors.

Only complete reels, as described below, are available (no short sections or single frequencies). The prices given include shipping charges to all points within the United States; shipping charges to other countries are additional.

35-Mm. Visual Film

Approximately 500 feet long, consisting of special targets with the aid of which travel-ghost, marginal and radial lens aberrations, definition, picture jump, and film weave may be detected and corrected.

Price \$37.50 each.

16-Mm. Sound-Film

Approximately 400 feet long, consisting of recordings of several speaking voices, piano, and orchestra; buzz-track; fixed frequencies for focusing sound optical system; fixed frequencies at constant level, for determining reproducer characteristics, frequency range, flutter, sound-track adjustment, 60- or 96-cycle modulation, etc.

The recorded frequency range of the voice and music extends to 6000 cps.; the constant-amplitude frequencies are in 11 steps from 50 cps. to 6000 cps.

Price \$25.00 each.

16-Mm. Visual Film

An optical reduction of the 35-mm. visual test-film, identical as to contents and approximately 225 feet long.

Price \$25.00 each.

SOCIETY OF MOTION PICTURE ENGINEERS
HOTEL PENNSYLVANIA
NEW YORK, N. Y.

JOURNAL

OF THE SOCIETY OF

MOTION PICTURE ENGINEERS

Volume XXXIV

June, 1940

CONTENTS

	<i>Page</i>
Sixteen-Mm Equipment and Practice in Commercial Film Production.....J. F. CLEMENGER AND F. C. WOOD	555
Direct 16-Mm Production.....L. THOMPSON	565
A Carbon Arc for the Projection of 16-Mm Film..... W. W. LOZIER AND D. B. JOY	575
Projection Supervision, Its Problems and Importance..... H. RUBIN	580
The Projectionist's Interest in Auditorium Viewing Conditions B. SCHLANGER	585
A Personal Safety Factor for Projection Practice. . T. P. HOVER	589
Defects in Motion Picture Projection and Their Correction. . . I. GORDON	596
Records for the Projection Room.....J. R. PRATER	601
Stereophonic Reproduction from Film.....H. FLETCHER	606
The Effects of Ultraviolet Light on Variable-Density Recording and Printing.....J. G. FRAYNE AND V. PAGLIARULO	614
Silent Variable-Speed Treadmill.....J. E. ROBBINS	632
Remarks by the President at the Opening of the Atlantic City Convention.....E. A. WILLIFORD	637
Current Literature.....	639
Fall Convention at Hollywood, October 21-25, 1940.....	642
Society Announcements.....	644
Index, Vol. XXXIV (January-June, 1940)	
Author.....	646
Classified.....	650

JOURNAL

OF THE SOCIETY OF

MOTION PICTURE ENGINEERS

SYLVAN HARRIS, EDITOR

Board of Editors

J. I. CRABTREE, *Chairman*

A. N. GOLDSMITH

A. C. HARDY

T. E. SHEA

J. G. FRAYNE

L. A. JONES

G. E. MATTHEWS

E. W. KELLOGG

Subscription to non-members, \$8.00 per annum; to members, \$5.00 per annum, included in their annual membership dues; single copies, \$1.00. A discount on subscription or single copies of 15 per cent is allowed to accredited agencies. Order from the Society of Motion Picture Engineers, Inc., 20th and Northampton Sts., Easton, Pa., or Hotel Pennsylvania, New York, N. Y.

Published monthly at Easton, Pa., by the Society of Motion Picture Engineers.

Publication Office, 20th & Northampton Sts., Easton, Pa.

General and Editorial Office, Hotel Pennsylvania, New York, N. Y.

West Coast Office, Suite 226, Equitable Bldg., Hollywood, Calif.

Entered as second class matter January 15, 1930, at the Post Office at Easton, Pa., under the Act of March 3, 1879. Copyrighted, 1940, by the Society of Motion Picture Engineers, Inc.

Papers appearing in this Journal may be reprinted, abstracted, or abridged provided credit is given to the Journal of the Society of Motion Picture Engineers and to the author, or authors, of the papers in question. Exact reference as to the volume, number, and page of the Journal must be given. The Society is not responsible for statements made by authors.

OFFICERS OF THE SOCIETY

- * *President*: E. A. WILLIFORD, 30 East 42nd St., New York, N. Y.
- * *Past-President*: S. K. WOLF, RKO Building, New York, N. Y.
- * *Executive Vice-President*: N. LEVINSON, Burbank, Calif.
- ** *Engineering Vice-President*: D. E. HYNDMAN, 350 Madison Ave., New York, N. Y.
- * *Editorial Vice-President*: J. I. CRABTREE, Kodak Park, Rochester, N. Y.
- ** *Financial Vice-President*: A. S. DICKINSON, 28 W. 44th St., New York, N. Y.
- * *Convention Vice-President*: W. C. KUNZMANN, Box 6087, Cleveland, Ohio.
- * *Secretary*: J. FRANK, JR., 356 W. 44th St., New York, N. Y.
- * *Treasurer*: R. O. STROCK, 35-11 35th St., Astoria, Long Island, N. Y.

GOVERNORS

- * M. C. BATSEL, Front and Market Sts., Camden, N. J.
- * J. A. DUBRAY, 1801 Larchmont Ave., Chicago, Ill.
- ** A. N. GOLDSMITH, 580 Fifth Ave., New York, N. Y.
- ** H. GRIFFIN, 90 Gold St., New York, N. Y.
- * P. J. LARSEN, 29 S. Munn Ave., East Orange, N. J.
- * L. L. RYDER, 5451 Marathon St., Hollywood, Calif.
- ** A. C. HARDY, Massachusetts Institute of Technology, Cambridge, Mass.
- * H. G. TASKER, 5451 Marathon St., Hollywood, Calif.

* Term expires December 31, 1940.

** Term expires December 31, 1941.

SIXTEEN-MM EQUIPMENT AND PRACTICE IN COMMERCIAL FILM PRODUCTION*

J. F. CLEMENGER AND F. C. WOOD**

Summary.—Today's commercial film is designed to accomplish a specific purpose and is therefore particularly directed to a specific audience. Prior to the introduction of the 16-mm sound projector, commercial sound-films could for the most part be shown only to theatrical entertainment audiences.

The immediate acceptance and rapid growth in use of 16-mm sound projection equipment for the first time made it possible for the commercial film producer to select the audience most useful to him.

At first practically all commercial 16-mm sound-films were made on 35-mm equipment and subsequently optically reduced to obtain 16-mm prints. It soon became obvious that it would be desirable to produce these films in the same medium in which they were to be shown. Among the advantages to be gained by such procedure were the absence of fire risk and consequent freedom from legal restrictions, the compactness and portability of equipment, lower raw-stock and print costs, and greater flexibility.

The introduction on the market of practical 16-mm sound projection equipment and its widespread adoption for the presentation of commercial or industrial motion pictures led to corresponding changes in production technic. The greater convenience and simplicity of handling equipment for the smaller-size film soon made it obvious that it would be desirable to produce non-theatrical motion pictures in the same medium in which they were to be exhibited. However, at the time the 16-mm sound projector was introduced it was necessary to produce industrial films in the 35-mm size and subsequently reduce optically to 16-mm for the release prints.

The obvious need for direct, efficient 16-mm recording equipment, to be used in conjunction with the already available 16-mm camera equipment, spurred research and resulted in the development of 16-mm sound recording equipment capable of producing very high quality results. Such equipment forms part of the subject of this paper.

* Presented at the 1940 Spring Meeting at Atlantic City, N. J.; received April 20, 1940.

** Sound Masters, Inc., New York, N. Y.

Our production of sound motion pictures in the 16-mm medium, beginning in 1936, has resulted in the development of practices and technics considerably different from those employed in the 35-mm medium. Four years of experience in the production of 16-mm sound motion pictures has brought with it improvements in technic and refinement in equipment design. At the present time it may be said that the 16-mm sound print which we produce directly in the 16-mm size is superior to the results obtained by optical reduction of 35-mm track.

We propose to discuss the technics and equipment which we use in the production of 16-mm commercial sound motion pictures, and how we coördinate 16-mm and 35-mm facilities in special production problems. We find a growing tendency among commercial and industrial organizations that have a definite need for films, to take a more active part in the production of those films. In many cases, skeleton motion picture departments have been established within these concerns to handle the preliminary stages of motion picture production. Generally, these departments are not equipped to complete a sound production. They rely to a great degree upon the assistance of professional motion picture producers to carry the production through to its finished form. In our case, many of our direct 16-mm productions are partially completed by the time they reach us. Let us review a specific example of a production problem of this type.

The client, in this case, is a large western railroad which, for some years, had produced silent 16-mm color-films within its own organization. These films were distributed to the various passenger agents of the railroad, and in addition were made available to such interested groups as civic organizations, schools, and fraternal organizations. Most of these films were of the scenic type and they had all been produced in 16-mm Kodachrome. While satisfactory results were obtained with the use of the films in silent form it soon became obvious that their utility would be greatly increased if they were scored in sound. The photographic department of the railroad, not being equipped to handle this phase of production, came to us for the completion of the task.

In this specific case, therefore, we had a completed 16-mm Kodachrome film in silent form. The railroad furnished sufficient information for the preparation of a script. It was our problem to develop this raw material into a finished sound motion picture.

For such a job our first step is to prepare a black and white dupli-

cate, or work print, for scoring and timing purposes, in order to avoid unnecessary handling of the original Kodachrome. In this scoring print, allowances are made for titles and optical effects such as wipes and dissolves; leader or other fill-in film is used to set the film to its intended length.

Next we prepare a detailed shot list with accurate footages and a brief description of each scene. This is an application of one of the special technics which we find advantageous. Fig. 1 shows the shot list as normally used. Observe at the head of the form a note to the

SHOT LIST

Title _____

Cutter _____ Date _____

NOTE TO CUTTER: Please fill in first and last columns only. Measure footages from head of title or head of first scene to *start* of each individual scene.

Ftg. to Start of Scene	Scene Ftg.	Scene Time	Time Cue	Scene Description

FIG. 1. Form used for listing shots or sequences.

cutter: "Please fill in first and last columns only. Measure footages from head of title or head of first scene to start of each individual scene." In other words, the cutter is required to fill in an identifying description of each scene and to measure on an ordinary footage and frame-counter, the exact footage from the head of the picture to the start of each scene described.

Our production director fills in the balance of each sheet. The second column, headed "scene footage," is the measure of the footage from the start of one scene to the start of the succeeding scene. The third column, headed "scene time," is the conversion of this last footage into minutes and seconds. The fourth column, "time cue," is the accrued time from the beginning of the picture.

The script writer concerns himself only with the last two columns, headed "time cue" and "scene description." The data in these two columns, together with the details supplied by the railroad, give him all the information necessary to prepare a perfectly synchronized talk-strip. These time cues are transferred to the scoring script for the use of the narrator when the actual scoring is undertaken.

While the script is being prepared, the musical director, who is also provided with a copy of this shot list, selects and prepares appropriate music. This music may be on disks, on sound-tracks, or it may be an original performance in the studio at the time of the scoring. This part of the procedure is, of course, conventional.

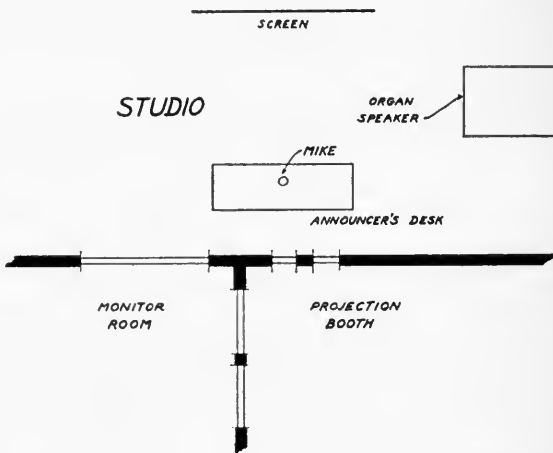

FIG. 2. General plan of studio and equipment rooms.

The next step is the actual scoring of the sound-track. Fig. 2 shows the general plan of the studio and equipment rooms used in scoring. In the scoring studio proper are the customary projection screen, the announcer's desk and microphone, and (since the Hammond electric organ is to be used as a source of some of the music for this particular production) the studio also contains a reverberation chamber for the organ loud speakers. The recording room and the projection room are placed side by side along the rear wall of the studio.

Fig. 3 shows the layout of the recording and projection rooms. In the separate projection room is placed all equipment that might produce noise distracting to the recordist. Here we find a 16-mm

projector driven by a synchronous motor which may also, upon occasion, be coupled to a 16-mm film phonograph, providing a mechanical interlock between the two machines. Behind the projector position are two more film phonographs which are used for dubbing sound effects or music. An intercommunication system permits selective conversation between the recording room, the projection room, and the studio.

The recording room is the usual sound monitor room, with all apparatus placed for convenience and ease of supervision. Facing

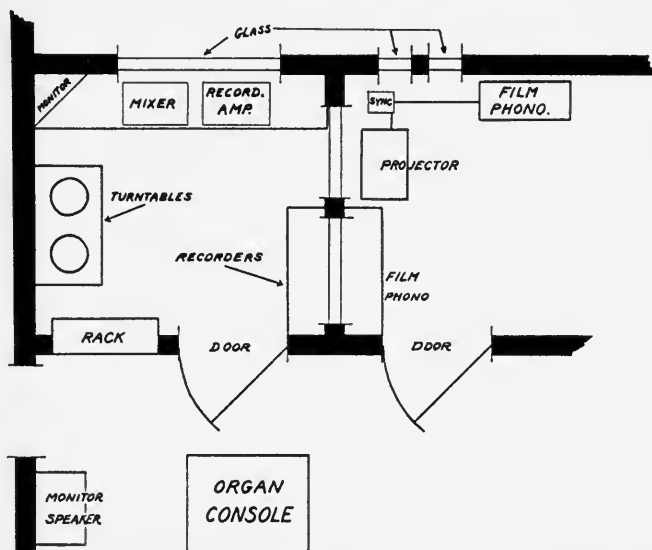

FIG. 3. Layout of recording and projection rooms.

the studio is a desk upon which are the recording amplifier and the extension mixer panel. On top of the extension mixer panel is located a large ammeter for the accurate indication of the exposure lamp current of the recorders.

To the right are the recording machines, with the 16-mm recorder placed on a shelf above the 35-mm recorder. To the left of the monitor desk are the phonograph turntables, synchronous at both 78 rpm and $33\frac{1}{3}$ rpm. In the rear of the monitor room is located the amplifier rack, the back of which opens through a partition in the wall to provide easy access to the tubes and other equipment. In

this rack are located various amplifiers and power supplies as well as a jack panel to permit interconnection of the various items of equipment required for the specific recording.

The door in the rear of the recording room remains open, the position of the electric organ console permitting the organist to see the screen during recording. A monitor speaker is beside the console, through which the organist hears not only the music of the organ but also the narrator's voice and all other sounds as actually recorded. The organist hears the mixed output. Glass partitions are provided between the recording room and the projection room and between each of these rooms and the studio, so that it is possible to observe the operation of all equipment from any of these three points.

It is interesting to note that every machine indicated in the layout is operated by a separate single-phase synchronous motor. It has been found in practice that the acceleration rates of the machines powered with these motors do not vary to an appreciable degree, and it is therefore unnecessary to provide a Selsyn interlock. A commercial 16-mm projector is used, and since commercial projectors are not manufactured with synchronous motors, such a motor is provided externally to drive the projector through its shutter shaft.

Let us now proceed to consider the actual scoring of the film. Since the release prints in this instance are to be on Kodachrome, it is necessary that the sound be recorded as a negative from which a black-and-white track print is made. This track print is then used in combination with the Kodachrome picture original to make a combined Kodachrome release print. The track print must have its emulsion face the same way as the emulsion on the Kodachrome original, and for that reason it is necessary to thread the recorder so that it will operate from left to right, which is the opposite direction from that normally used for black-and-white release prints made from negative picture and negative track.

At this point we find that our technic is again widely different from 35-mm practice, in that the sound recorder must operate with equal facility in either direction. This is accomplished in the recording machine by merely operating a motor-reversing switch. A special gear-driven magazine automatically takes up in the proper direction. The advantage of this feature can be readily appreciated when it is considered that the change from one direction to the other is quite often made. The film in the magazine of the recorder must be wound so that the emulsion and sprocket-holes of the film are in the proper

relative positions. Film wound for this purpose is usually designated as the *A* winding.

Before the work print is threaded in the projector, a starting leader of 4 feet 32 frames is attached. The *start* frame of the leader is placed in the picture aperture of the projector. To provide a synchronizing mark, the sound-track negative is then punched at the point where the recording light-beam strikes the film. Since this synchronizing mark is in the sound-track position, it appears in the prints of the sound-track and may be used for checking synchronism at a later



FIG. 4. Projector and film-phonograph with drive.

time. If dubbing machines are used to provide sound effects or music track, these machines are also threaded up with the standard start as used in the projector.

After the script has been rehearsed, levels checked, and all other preparations concluded, the recordist presses the master switch button which starts all the synchronous motors on the machines being utilized, and the actual recording begins. At the conclusion of the recording, complete detailed log sheets are made up and one copy is sent with the exposed sound-track negative to the laboratory together with developing and other laboratory instructions. After the nega-

tive track has been developed a track print (without picture) is made and returned to the studio for checking.

Referring again to Fig. 3, the 16-mm film-phonograph and the 16-mm projector are mechanically interlocked since they are driven by the same synchronous motor. The work print is threaded up in the projector while the track print is threaded up in the film-phonograph; in both cases the original start marks are observed. The track and picture are then run together to check the synchronism and to check the quality of sound recording. At this point, the concern for which the picture is being made is enabled for the first time to see and hear the picture substantially as it will be in its finished form.

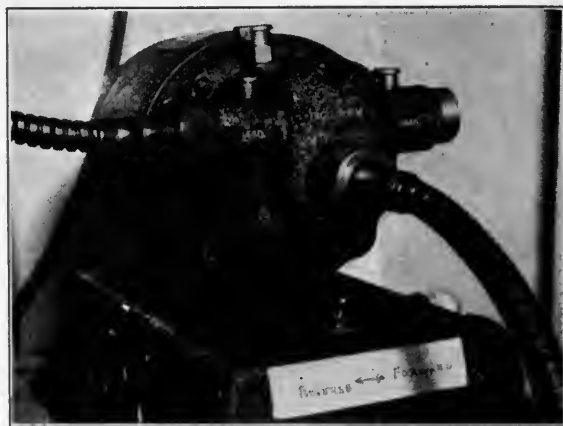

FIG. 5. Synchronous motor and drives for interlock.

Since this procedure involves both special technic and special equipment, Fig. 4 has been drawn to show how the mechanical interlock is accomplished. On the left is a 16-mm projector; on the right is the 16-mm film-phonograph; and in the center, the synchronous motor, which is connected to both machines.

In Fig. 5, a close-up of the synchronous motor and drives, it will be seen that the film-phonograph is driven directly through a flexible drive from the shaft of the motor at 1800 rpm. The shutter shaft of the projector, however, runs at 1440 rpm, and its flexible shaft drive works out of a noiseless gear-box. A flywheel mounted on the shaft of the single-phase synchronous motor reduces starting acceleration

to prevent damage to the projector mechanism and the film. The direction of motion of both the projector and film-phonograph may be reversed by throwing the reversing switch of the motor, if it is desired to re-check the synchronism of a section of the film.

Both the projector and the film-phonograph are equipped with controls on the sound optical system to permit instantaneous change of focus from the front to the back of the film. These adjustments are required to provide the necessary flexibility when running negative, positive, and reversal film.

Let us now return to our example of production procedure. The two films, the Kodachrome original and the track print, are next sent to the laboratory for duplicate Kodachrome printing. It is interesting to note that the same optical one-to-one sound printer is used for printing the sound-track on the combined Kodachrome duplicate as was used in making the black-and-white track print.

The exposed combined print is then processed by the Eastman Kodak Company. Upon their return, the combined Kodachrome duplicates are checked for both picture and sound quality before being turned over to the client.

Let us briefly consider other production problems in which the equipment described is employed. Since recorders, film-phonographs, and amplifiers are provided for both 16-mm and 35-mm recording, they may be used in combination with 16-mm and 35-mm cameras to bridge many once-formidable gaps in the production of industrial pictures.

A large part of our business requires that the picture be shot on 35-mm film to provide library material for subsequent theatrical use while the immediate production schedule calls for 16-mm release prints for non-theatrical distribution. The procedure in such cases is to score directly in the 16-mm film size since the resulting sound-track is superior in quality to an optical reduction of 35-mm track.

Occasionally, it is desirable to shoot simultaneously 35-mm black-and-white and 16-mm Kodachrome while recording with double-system recorders in both film sizes. Single-phase synchronous camera motors in combination with the recording equipment already described make it possible to meet this rather complicated production problem quite easily.

On location assignments requiring double-system operation, the flexibility and portability of the 16-mm equipment are of great advantage to the producer. The use of a 110-volt, 60-cycle converter

operating from storage batteries insures duplication in the field of all essential studio operating conditions.

Camera equipment employed for 16-mm production includes a single-system Berndt-Maurer camera and, for double system, a number of Eastman Kodak Special cameras. For 35-mm production Wall and Mitchell cameras are usually preferred. Each camera is provided with a single-phase synchronous motor for which can be substituted a battery-powered d-c motor.

It seems clear that the new technic of production that we have discussed can be attributed entirely to advances in the 16-mm film and equipment fields. Such advances make it possible for us to develop methods whereby we can offer the type of service that we have described as it applies to a great railroad. The demand for such service has been created by countless progressive industrial organizations, and the demand is rapidly growing. On the basis of present and past performance it is logical to assume that facilities for satisfying the demand will also continue to expand.

DIRECT 16-MM PRODUCTION*

LLOYD THOMPSON**

Summary.—There are so many reasons why 16-mm film can and should be used that the industrial and educational user is using more and more of it. The production of 16-mm sound pictures by the direct method has been making progress. Today there are a number of companies using direct black-and-white and color sound productions in the 16-mm size. Many who are trying to use the method do not understand the proper technic or do not use the best commercial facilities available, which make the process slow in being generally accepted.

Certain advantages and economies are effected by using the direct 16-mm production method which make it desirable for the non-user of sound-films to use this medium for the first time, and for others to use the film more effectively. Complete commercial 16-mm production and laboratory facilities are now available that equal those of the best 35-mm industrial producers. The problem of making wipes, fades, dissolves, and other tricks in the laboratory has been solved for direct 16-mm production. Re-recording facilities for blending sound from several sources are available, making it possible to achieve truly professional results by the direct method. A few examples of direct 16-mm productions are given.

During the past a number of papers have been read before this society on the future of 16-mm film, the development of 16-mm sound projectors, the recording of sound by the direct 16-mm method, and various uses of motion pictures in business. There is one interesting point in the growth of the 16-mm industry which has not been discussed at any length—the industrial producer and the production of industrial and educational films by the direct 16-mm method. At first it was the industrialists and educators who happened to be enthusiastic amateurs who occasionally photographed interesting phases of their business or work, and who later felt they could use industrial movies in their own fields of endeavor and proceeded to make industrial or educational shows. Of course, a number of these shows did not accomplish a great deal, but some of them did enough good for the managements to see that motion pictures could be helpful, and the companies or schools, as the case might be, either con-

* Presented at the 1940 Spring Meeting at Atlantic City, N. J.; received March 18, 1940.

** The Calvin Co., Kansas City, Mo.

tinued to make their own pictures or turned the jobs over to industrial producers.

Part of the growth of the direct 16-mm producer has been caused by the efforts of these pioneers. They saw what could be done with direct 16-mm production, and were sold on making pictures by this method. As their motion picture programs became more ambitious, and they no longer felt they had the time, the equipment, or perhaps the ability to make bigger and better pictures, they turned to the direct 16-mm producer for help in making the entire show, or in finishing their own jobs. Most of the established professionals were not interested in helping to finish these "amateur" jobs, and the amateur was forced to turn elsewhere for his help; thus the direct 16-mm professional producer grew.

The same thing which has helped to promote direct 16-mm production has, unfortunately, also helped to give it a black eye. Too many amateurs, small commercial studios, and promoters have gone into the business of producing business movies with no more equipment than a \$37 camera and an unlimited amount of nerve. It is perfectly possible to make a fairly good industrial movie with a \$37 camera, provided one has had the experience and knows where to get the necessary laboratory help. A number of the pictures made by these inexperienced producers have been pretty horrible examples, and, as a result, direct 16-mm production has received a black eye—not because the medium was not suitable, but because it was not handled properly. There are some commercial studios and some amateurs who know how to produce a very satisfactory industrial motion picture, and have done so. Their work should be encouraged and we should give them all the help we can, because some of them will develop into large users. The promoter who goes about the country making industrials or educational pictures works with 16-mm film because it is cheaper than 35-mm film and he can present a good story to his prospect. He used 35-mm before 16-mm was introduced, and his pictures would be just as bad if they were shot on 70-mm film. The industry will always have some badly made pictures, but the direct 16-mm method will get most of the blame because it is a new medium, as yet few people know how to use it properly, and 35-mm pictures have a good reputation built up over a period of years by good work by the best technicians.

The improvements made in recording and printing of direct 16-mm sound during the past year have given this method of production a

big boost. The development of fine-grained, high-speed 16-mm films has helped picture quality and made difficult factory shots easy to shoot on the 16-mm size. Improvements in color duplication in both the photography and the sound have resulted in making a number of direct 16-mm sound pictures in color.

Almost all kinds of pictures have been made by direct 16-mm production except the dramatic sound entertainment show for theater use. Those films which are most suitable for this type of production are educational films, sales-training films, dealer training, service training, employee training, employee relations, factory pictures to be shown before groups where 16-mm projection equipment is almost demanded, safety-training films, and direct-sales films.

There is, of course, only one real object for making any picture in the 16-mm size, and that is to save expense. The economy and convenience (and convenience is again mostly a matter of expense) of 16-mm projection have been thoroughly discussed here before. The cost and convenience of direct 16-mm production have not. To begin with, there is the matter of raw-film cost. The following table has been prepared comparing the cost of raw stock and laboratory service for a thirty-minute production made in both 16-mm and 35-mm sizes. An effort has been made to use average costs as much as possible in this comparison, although it is admitted that prices may vary for both the 16-mm and the 35-mm. However, in both case these prices are taken from published prices of various laboratories and no attempt has been made to find high prices for 35-mm and low ones for 16-mm. As a matter of fact, the higher-priced 16-mm laboratory service has been used in most cases because of the better quality obtained. It is also admitted that many an industrial show is made that does not use so much raw stock as listed, or certain processes such as dupe negatives or re-recording are not used, but it is felt that these extras make a show much more effective and the cost will vary in proportion no matter which film size is used. It might also be interesting to point out here that it has been estimated that production by the 35-mm three-color process costs about six times as much as black and white. Industrial 16-mm producers figure three-color 16-mm production only fifty per cent higher than black and white.

Other economies might be mentioned, such as less expensive equipment needed for 16-mm production; the equipment is lighter, which reduces transportation costs; less help is needed in production; and if there is traveling to be done, as is usually the case in in-

dustrial shows, one automobile and a trailer will carry a crew and the equipment. Bulkier equipment will require more units of transportation. When a picture must be made on a limited budget, such things as transportation of film to the laboratory will not be over-

35-MM PRODUCTION

1000' negative, at 0.06 (list)	\$ 60.00
Develop 1000' negative, at 0.015	15.00
1000' positive print, at 0.0325 (for editing)	32.50
1000' sound recording film, at 0.01	10.00
Develop sound film, at 0.015	15.00
Positive print from sound, at 0.02	20.00
	<hr/>
	\$ 152.50
Cost per 11 minutes of photography and sound shot 3000' picture	457.50
Approximately 5 times as much footage as used shot	2287.50
3000' Lavender or Master positive (for making dupe negative), at 0.05	150.00
Film for re-recording sound	30.00
Developing re-recorded sound	45.00
35-mm. dupe negative from master positive	180.00
	<hr/>
Cost of negative material and developing ready for printing	\$2692.50

DIRECT 16-MM PRODUCTION

400' Triple S Reversal film, list \$6.00 per 100'	\$ 24.00
400' reversal print for editing, net	13.34
400' sound recording film, at 0.008	3.20
Develop 400' sound, at 0.015	6.00
Positive print from sound, at 0.015	6.00
	<hr/>
	\$ 52.54
Cost per 11 minutes of sound and photography, shot and ready to edit picture 1200' long	157.62
Approximately 5 times as much footage as used shot	788.10
1200' film for re-recorded sound	9.60
Develop re-recorded negative, at 0.015	18.00
1200' Special dupe negative, net	48.00
	<hr/>
Cost of film and developing ready for printing	\$ 863.70

looked; insurance rates on storage, and laboratory space for 16-mm safety film are less than for 35-mm nitrate film.

Color is probably even more important in industrial or educational pictures than in entertainment production for this reason. Hollywood films are usually made for entertainment, and the story and the acting are of primary interest. By this I do not mean to belittle the

technical work, but people go to the movies mainly for the purpose of being entertained, and not for praising the good sound, the excellent lighting, or the beautiful colors. They are, the producers hope, absorbed in the story. An industrial production may have to interest its audience with the beauty of a new product, or to show a grocer how he should set up a good-looking window display where color is all-important. Even a factory filled with a lot of machinery is more interesting in color. An educational film showing a surgeon performing an operation will be more instructive in color and sound. Because direct 16-mm color sound-films can be produced so economically as compared with 35-mm three-color process productions, the direct 16-mm method is gaining favor every day.

Potential buyers and engineers have said that direct 16-mm production will never be entirely successful until there is good 16-mm laboratory service and until printers are built that can make special trick wipes, dissolves, and double-exposures in the laboratory. The most consistent results in 16-mm production have been obtained by the use of reversal film for the original photography. There are any number of reasons for using reversal film. To be specific, it is fine grained, the photographic quality is very good, it gives little trouble in editing because dirt spots print as black instead of white as in the case of negatives, and thus it is easier to handle. Furthermore, the two major film companies both have laboratories for the processing of the film by automatic machines and the standard of work turned out by these laboratories is better than found in most other 16-mm laboratories. Notice that I said "in most others," as there are a few laboratories doing 16-mm work that have very high standards; but they are few, and are not located at strategic points from coast to coast as are the film manufacturers' laboratories.

There are some who may object to the statement that reversal films should be used for the originals, and as soon as someone is willing to show me films made by any other method that show the same good consistent quality, I will be willing to listen. There has been some objection to reversal originals because of the high cost of reversal prints. If a number of prints are wanted a dupe negative can be made, and negative-positive prints made as cheaply as from the original negative. A few years ago I could not have recommended such a procedure but improvements in dupe negative stock and developing procedure have made dupe negatives available that are probably as good as reversal prints to the average audience. Fur-

thermore, a dupe negative is an insurance for the original and the final prints come out with the emulsion toward the lens, which is preferred though not necessary. These special dupe negatives are available from only a few laboratories at present, but they are available. Another reason for using reversal film for originals is that color films must be made in this way and black-and-white can be used with the color; the emulsion will then come out the same on both the black-and-white and the color film. Since the present 16-mm colored picture must be made on reversal film, and the person working with it is familiar with handling it, it is easier for him to use reversal for black-and-white pictures.

The producer of direct 16-mm pictures should be very careful in choosing his laboratory and he should be fairly familiar with possibilities and procedure. Good laboratory service is available if the client only takes the trouble to find it. Tremendous improvements have been made in the last two years and there should be a continued improvement.

There has been a cry for dissolves, wipes, double-exposure, and other trick effects for direct 16-mm productions. Various attempts have been made by direct 16-mm producers to produce these effects with optical printers, masks, and chemical treatment, but they have never been perfectly successful because most of them depended upon making the effect on a separate piece of film and then splicing the effect into the original for duplication. This caused a change in photographic quality, or the effect was not smoothly done, with the result that when the final picture hit the screen the effect was so drastic that the audience was well aware of an effect, although the effect was not always the one that the editor intended.

I am glad to say that this has been remedied, and we are now able to make almost any effect wanted except the "flip-flop," and the result is smooth. There is no jump on the screen when the effect starts, and there is no change in the photographic quality. It is possible to use the process in color printing. With these new improvements in printing, there is no reason why a picture can not be made to look professional by the direct 16-mm method.

Direct 16-mm recording can equal or surpass 35-mm reduction sound printing, as has been demonstrated before this Society, and this type of recording is commercially available. There are 16-mm recording channels available commercially for re-recording sound from several sources into one track, to make a smooth sound-track; and

when combined with a smoothly edited picture, the result is a professional-looking piece of work. Of course, this does not mean that good camera work and good sound recording work are not essential. They are, and this final laboratory work merely dresses up the picture as a paint job finishes a piece of machinery.

Today there are direct 16-mm producers who are as well equipped as any 35-mm industrial producer. There are direct 16-mm production studios where permanent staffs are maintained and where complete shows can be made from scenario to finished release prints without farming out a single operation in the entire production. Complete studio recording channels, re-recording channels, complete portable equipment, single-system sound cameras, and laboratory services are all available in direct 16-mm. I do not believe any more complete facilities are offered by any 35-mm industrial producer. Furthermore, any of these services are available to the amateur, the industrial user, or the maker of educational pictures, whether he desires a twenty-five-cent title or a complete dramatic industrial in sound and color.

As was stated before, the reason for using direct 16-mm production is that it is economical, not only as to film costs, but in other ways. Business concerns have not been able to use motion pictures to their full advantage because of the cost. This is probably not the case of large national advertisers, but it is true of companies who serve only small sections of the country, and there are thousands of such concerns. Direct 16-mm opens the way for many of these concerns to use movies. Let us look at a few of these companies and see the types of show they are using.

For example, there is a small road equipment company that sells road-building and maintenance machinery. Most of their sales are confined to one State, and perhaps only some of the counties of that State. For several years the owner of the business had made his own silent pictures, showing his equipment in operation. Because he knows what features of his road machinery to emphasize, he is able to photograph the machinery to show these points. He claims that his pictures have helped him to close many a sale. True, a professional sound job would probably do as much or more good, but the company could not in the beginning budget money for a professional picture. Some day this concern may go to sound pictures and it will probably be direct 16-mm sound with the pictures they already have.

I know of four oil companies who have used direct 16-mm sound

productions. Some of them have been professionally made. Others have been made by their sales-promotion departments, the sound-tracks being added by a laboratory. On some occasions, the sales-promotion departments have made part of the photography and had the rest made by a studio; and then had the studio edit the picture and record the sound. Some of the productions have been made in color.

The subject material in these films has been varied. Some of the pictures were of the all-synchronous type shows, for training station operators in driveway selling. One show was of the candid type. Station operators were photographed in various locations without their knowledge by the sales-promotion department's own photographer. Errors in servicing their customers were recorded on the film, which was edited, and a sound-track added, and then shown to the operators. It was very effective, and the whole show, about thirty minutes long, cost less than \$1500. Of course, this was a rather simple show, and did not require six times as much film as was used in the final production. Other pictures have included such material as the processing of the gasoline and greases, and pictures to celebrate an anniversary. Some of these companies are not classed as nationally known refiners or advertisers. The sale of their products is limited to six or eight States or more, and some to approximately three or four States.

A manufacturer of washing machines introduced a new model to his dealers by means of a direct 16-mm sound production. The production was taken with actual factory sound effects and later re-recorded with voice and music. The manufacturer has said that the show was actually better than taking the dealers through the plant because, after all, they showed the dealer what they wanted and only what they wanted him to see.

A coal company tried for several years to interest a large utility company in selling coal stokers. Finally, they made a 16-mm picture showing the processing of the coal and the advantages of the stoker. They added a sound-track, and the film was shown to so many local civic organizations who evinced so much interest that the utility company decided to promote the sale of the stokers. The picture has been used a great deal elsewhere, but the company figures that the picture was more than paid for in this one deal. Of course, a more expensive production would have probably been worth while here but the company would not have taken a chance on an expensive

production. Many companies who start in a small way with a home-made direct 16-mm production find the idea a potent one and later desire better productions. Thus they turn to an industrial producer for at least part of their work.

A soft-drink manufacturer wanted a sales-training program consisting of a series of short pictures. He wanted a short movie at a slide-film price. He found it could be done by direct 16-mm production, and a special 16-mm sound projector selling at a retail price of \$139 was developed. The small machine was designed for audience groups of approximately twenty persons. Most bottlers do not have more than twenty drivers, and the machine is filling another need, long felt—an inexpensive projector for small groups, for direct selling in the office or home. Direct 16-mm productions will fit in well here where pictures must be changed frequently to keep pace with new improvements, new models, and new products.

Of course, the larger business concerns who have national distribution can usually afford to pay higher original production costs, but we have found that even the larger companies are interested in saving money on certain types of shows.

Business is turning to direct 16-mm production because this is a medium that will show a profit when more costly productions will not. People who want motion pictures for educational use are turning to it because their budgets are usually extremely limited. The field of educational pictures is virtually untouched today in spite of all the efforts that have been made to use motion pictures in education. Practically every large college today makes motion pictures of football games for use in coaching, and in some cases, for scouting purposes. Some also use these same pictures for college publicity. In some cases this equipment is owned by the athletic departments and in other cases it is owned by the colleges. Most colleges now have enough equipment to make their own silent educational films, and every day more interest is being shown. To date the biggest percentage of these pictures have been silent, because the limited budgets would not allow sound-tracks to be added. However, in some instances, budgets were large enough to add sound.

Several State fish and game departments have made direct 16-mm sound pictures. Some of these have been so successful that these departments now make a new picture each year. An agricultural college made a 16-mm color picture on the production of eggs, and added sound. A doctor made a picture showing an improved way of setting

broken bones. He recorded a lecture on the film so that it could be shipped to various medical meetings with his personal lecture to go with it. The medical fraternity has been a big user of direct 16-mm ever since it was introduced. Most of this work has been silent and the chances are that few doctors will ever want to make enough pictures that it will pay them to buy recording equipment, and they will use the services of the direct 16-mm industrial producer for their recording work.

There are, of course, some educational institutions and some business concerns that maintain complete photographic departments and own complete equipment for making the sound as well as the picture. Some have 35-mm equipment and others 16-mm. Again, of course, it is a question of how much work there is to be done and how much the budget will allow as to whether the organization owns a complete photographic department. Many more cases might be cited of direct 16-mm productions, and every month *Movie Makers* publishes a list of practical movies, most of which have been made in the 16-mm size. Most of these have been silent, but more and more cases of sound are creeping in.

Today there are few concerns who have chosen to call themselves direct 16-mm producers because they have felt that 16-mm film was meant for the amateur, and to be known as direct 16-mm producers would be hard on their dignity. The future will see more of the 16-mm type of work and the day will come when anyone desiring to produce a movie will consider 16-mm as well as 35-mm.

A CARBON ARC FOR THE PROJECTION OF 16-MM FILM*

W. W. LOZIER AND D. B. JOY**

Summary.—A new high-intensity carbon trim has been developed for the projection of 16-mm film. The characteristics, operating data, and performance of this "Pearlex" trim are described. The light from the original combination of carbons has been modified to give a color quality suitable for 16-mm color-film which has been processed for projection with incandescent lamps. Measurements show that this new combination, in lamps specifically developed for it, provides approximately three times as much light as was hitherto available for 16-mm projection, thus greatly improving the projection of 16-mm film to large audiences.

There have been many improvements during the past few years in the quality of 16-mm film and its projection. The result has been the increased use of 16-mm motion pictures in the educational and non-professional fields. The addition of sound and natural color have been important factors in extending the scope of 16-mm as well as 35-mm film. The use of 16-mm film with large audiences in the non-theatrical field has resulted in most cases in projection far inferior to what is enjoyed in most motion picture theaters. This has been due to a great extent to a lack of a sufficient amount of light, necessitating the use of either an inadequate level of illumination or size of screen or a combination of both. This lack of illumination for large audiences has recently been corrected by the carbon arc light-source and lamps developed especially for this 16-mm field. A lamp for this purpose was recently described.¹ It is the purpose of this paper to describe the characteristics of this new carbon arc and the still more recent improvements in it.

Burning Conditions.—The carbon combination supplied has been called the "Pearlex" trim. The positive carbon is 6 mm in diameter and 8 inches long, while the negative carbon is 5.5 mm in diameter and 6 inches long. Both carbons are copper-coated and designed to operate in the coaxial arrangement without rotation. This combination was selected as a desirable solution to the demands of sufficient life of

* Presented at the 1940 Spring Meeting at Atlantic City, N. J.; received April 22, 1940.

** National Carbon Co., Fostoria, Ohio.

burning, low power consumption, adequate level of illumination, and heat tolerance of the film. The trim has been designed to operate at 30 amperes and 28 volts d-c. The 5.5-mm "Pearlex" negative gives a low consumption rate, and, as it is similar to the negative to be described in another paper,² avoids the formation of carbide tip which might be expected at the low arc voltage and low current.

The operating characteristics of the "Pearlex" trim are in many respects similar to those of the "Suprex" carbons widely used in the field of 35-mm film. Therefore, the use of magnetic flux and a low-voltage power source with slightly falling volt-ampere curve are factors which are important in obtaining the optimum stability of the arc. These factors have been adequately discussed in a previous publication.³ The rated conditions of 30 amperes and 28 volts result in a power consumption of less than 900 arc watts and a carbon consumption of about 6 inches per hour for the positive carbon and 3¹/₂ inches per hour for the negative carbon. The lengths of carbon supplied are therefore adequate for fully one hour's burning.

Color Quality of Light.—The original "Pearlex" trim was designed to give the snow-white color of light typical of the high-intensity arc which is well known from its application to 35-mm theatrical projection. The spectral energy distribution of this type of light is characterized by an essentially even balance of energy throughout the different wavelengths and colors of the spectrum. This has been found to be desirable for the projection of 35-mm film in color and in black and white. The 16-mm color-film which enjoys wide usage has been processed for projection with incandescent lamps, which differ from the high-intensity arcs in that they are relatively low in energy in the blue and high in energy in the red. As a result, when 16-mm color-film processed for incandescent lamps was projected by the snow-white light of the high-intensity arc, the blues were over-emphasized and the reds were subdued.

This trouble was corrected by a modification in the "Pearlex" positive carbon which alters the color of the light by subduing the blue light and intensifying the red light. This has resulted in a color of light which is satisfactory for both black-and-white and 16-mm color-film projection. Fig. 1 shows the spectral energy distribution of the radiation from the crater of the original and the color-modified "Pearlex" carbon. That the light from the color-modified carbon is less blue and more red is evident from the alteration of the spectral energy curve. This results in a reduction of about 650°K in the

color temperature. This alteration in the color of the light from the carbon arc is another example of the important fact that the carbon arc can be modified to give a most suitable color for the application at hand. This has also been illustrated by other recent applications of modification of color of the light from the carbon arc.⁴

Intrinsic Brilliancy and Amount of Screen Light.—Similar to the direct current arc obtained with "Suprex" carbons, the "Pearlex"

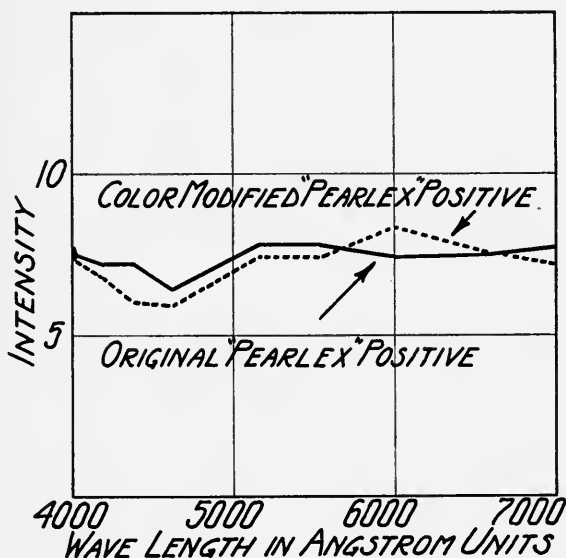

FIG. 1. Spectral energy distribution of positive crater radiation from 6-mm "National" "Pearlex" Positive—5.5-mm "National" "Pearlex" Negative at 30 amperes, 28 volts d-c.

trim is a high-intensity trim and shares the outstanding advantages of this type of arc. The result is a high intrinsic brilliancy which is, along with the speed of the optical system, a feature of prime importance for a high level of projected light. Fig. 2 shows a graph of the intrinsic brilliancy across the crater of the 6-mm "Pearlex" positive carbon at 30 amperes. It is seen that in the center of the crater the intrinsic brilliancy is about 350 candle-power per square-millimeter. The vertical lines show the portion of the crater which when magnified four times will cover the diagonal of the 16-mm projector aperture. It is apparent that this utilizes the most brilliant part of

the crater and still gives adequate coverage on the film. An elliptical mirror of 4X magnification and a collecting angle at the arc of 140 degrees will fill an $f/1.4$ lens. Therefore the new "Pearlex" arc is capable of more than filling the fastest projection lenses used today with 16-mm film.

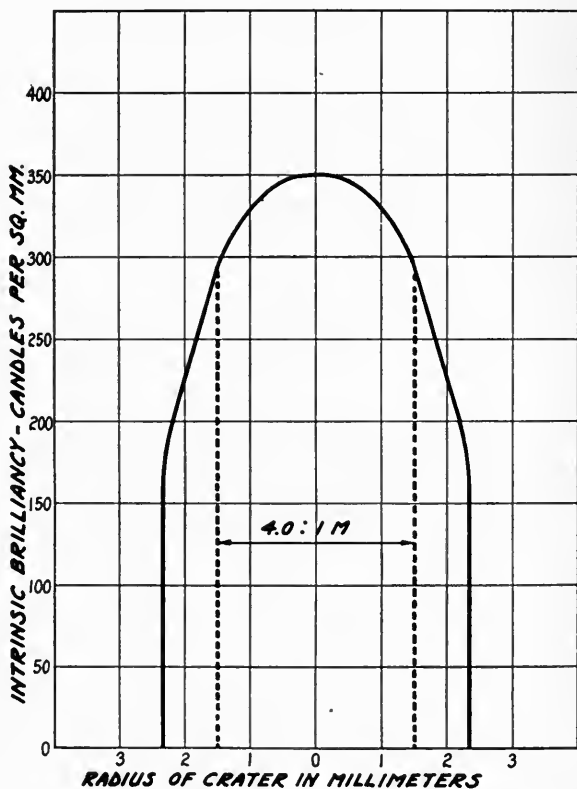

FIG. 2. Intrinsic brilliancy across positive crater with 6-mm "National" "Pearlex" Positive—5.5-mm "National" "Pearlex" Negative at 30 amperes, 28 volts d-c.

At 30 amperes and 28 arc volts with a 2-inch focus $f/1.6$ lens and an elliptical mirror with a collecting angle of 140 degrees, the "Pearlex" carbons project approximately 1000 lumens on the screen with a shutter common in 16-mm projectors, or about 1800 screen lumens with no shutter.

Special tests and published reports indicate that this "Pearlex" carbon combination provides approximately three times as much light as was hitherto available for 16-mm projection. It will therefore allow for more adequate screen illumination in the rapidly growing 16-mm non-theatrical field.

REFERENCES

¹ STRONG, H. H.: "A High-Intensity Arc for 16-Mm Projection," *J. Soc. Mot. Pict. Eng.*, **XXXIII** (Nov., 1939), p. 569.

² LOZIER, W. W., JOY, D. B., AND SIMON, R. W.: "A New Negative Carbon for Low Amperage High-Intensity Trims," presented at the 1940 Spring Meeting at Atlantic City, N. J.; to be published in a succeeding issue of the JOURNAL.

³ JOY, D. B., AND GEIB, E. R.: "The Non-Rotating High-Intensity D-c Arc for Projection," *J. Soc. Mot. Pict. Eng.*, **XXIV** (Jan., 1935), p. 47.

⁴ JOY, D. B., LOZIER, W. W., AND ZAVESKY, R. J.: "Recent Improvements in Carbons for Motion Picture Studio Arc Lighting," *J. Soc. Mot. Pict. Eng.*, **XXXIII** (Oct., 1939) p. 374.

PROJECTION SUPERVISION, ITS PROBLEMS AND IMPORTANCE*

HARRY RUBIN**

Summary.—The importance of thorough and continuous supervision of projection and sound equipments in the theaters, some of the problems connected therewith in the construction and the maintenance of the theaters; a brief outline of a few of the many details that must be examined and precautions that must be observed in order that the motion picture entertainment may be presented under the most nearly perfect conditions, are described by a Projection Supervisor for a theater chain. Emphasis is placed upon the benefits to be derived through the close coöperation between the supervisor and the projection personnel of the individual theaters and several measures for accomplishing this result are cited.

As is generally well known, supervision of projection and sound equipment is intended to effect the following results:

(1) To institute and to maintain conditions under which theater patrons may see and hear film plays with a maximum degree of comfort, safety, and satisfaction during the entire performance.

(2) To promote the most efficient methods of operation through the elimination of waste; by discovering incipient troubles and correcting these conditions before breakdown or other serious difficulties actually occur; by furnishing instructions and information regarding the routine work and duties of the projection personnel; by installing systems and schedules covering checking, lubrication, and cleaning of all items of equipment; and by investigating new devices offered to the trade, testing such devices and, after making a thorough study of all factors involved in connection with each particular theater, advising these theaters whether or not the substitution of the new devices for their present equipment would improve their screen or sound results or would effect reductions in operation costs.

In a paper such as this it would seem logical to begin at the point where thorough supervision should begin, *i. e.*, while the theater is still in the blueprint stage. The Supervisor should study each pro-

* Presented at the 1940 Spring Meeting at Atlantic City, N. J.; received April 10, 1940.

** Paramount Theaters Service Corp., New York, N. Y.

posed theater layout and advise the incorporation therein of every detail and item of equipment that will best achieve the objectives set forth above. He should check all wiring and conduit sizes, the capacities of switches and fuses, the estimated load of each circuit, and see that all sound and projection circuits and also the emergency house-lighting circuits are so installed and independently protected that trouble originating in any other circuits will not affect their proper operation.

He should make certain that the projection room is provided with facilities that will make it healthful, comfortable, and safe for the occupants. This means that adequate ventilation for disposal of gases generated by the arc, heating and cooling of the projection room, and running water and toilet facilities should be included in this room. Proper approaches and entrances to the projection room should be laid out, using a standard type of stairs where necessary but in no case permitting ladder approaches.

The Supervisor should acquaint himself with all the pertinent regulations issued by local authorities and should see that these are complied with in the construction work. Planning the arrangement of the equipment within the projection room so as to obtain the most convenient operation is a matter of prime importance. For instance, if house-light dimmers and curtain control are included in the projection room, it should be possible for the projectionist to manipulate them while at his position beside the projector and while looking through his observation port.

The Supervisor should concern himself also with the amount and the arrangements of the house lighting used during the picture, paying particular attention to the shading of these lights from the screen and from the eyes of the audience. The entrances to the auditorium should be so constructed that daylight will be excluded and can not possibly fall upon the screen. In order that those already seated be spared every distraction, the noise and movement of patrons entering the theater should be screened as much as possible by the generous use of baffles and acoustic material. The projection room should receive proper acoustic treatment to prevent the noise of projectors, monitor speaker, or conversations being transmitted to the audience. Observation ports should be glassed in, and projection ports stopped down to actual dimensions of the projected light-beam, and also lined with a suitable sound-absorbing material. All other ports should be so arranged that they may be kept closed when not in actual use. In

short, no factor related to presenting the program to the audience should be considered as being outside the province of the Supervisor, or to be disregarded by him.

Thorough supervision requires the making of periodical theater inspections, on which occasions the Supervisor would naturally look for any apparent screen faults, such as an unsteady picture, travel-ghost, uneven or poor screen illumination, scratched film, or oily film. He would, no doubt, obtain a great deal of information by observing the picture as projected on the screen. He should also note the condition of the picture screen. Innumerable other details will require his attention, such as checking of projector components for vibration wear, adjustments and tensions imposed on the film; the noise levels of projectors; equalizing the sound and the light outputs of projectors; determining the overall frequency response of each sound channel; examination of arc voltage and amperage; inspection of feeding mechanisms and lamp houses; examination of wire connections, fuses, and switches; determining whether or not undue heat develops in any of these items or its connections; checking the condition of theater reels, rewinders, and film cabinets; checking the condition of projector gears, shafts, and bearings, their lubrication and cleanness; checking the amount of backlash between the shutter and the intermittent sprocket; checking the condition of motor-generator brushes, brush rigging, commutator, bearings, end play of shaft, level position, lubrication, and cleanness. To list every possible fault which might develop in each item of equipment would serve no practical purpose here. A few of the most prominent points have, however, been listed above in order to indicate the extensive inspection and checking required.

The Supervisor will naturally direct his efforts to prolonging the life of the release prints. Most instances of film damage can be directly attributed to lack of supervision, to having permitted equipment wear to develop to the point where damage to the film is inevitable, to faulty adjustment of projector parts, to excessive tension in the film or to plain stupidity concerning the handling of film. Usually film is not taken out of service because the sprocket-holes have become so worn that the further use of the film would be hazardous. More frequently the film is retired because it has become so badly scratched and soaked with oil that its entertainment value has declined to the vanishing point. Scratching of film, together with the second notorious trouble, oiliness of the film, may be reduced to a

minimum by seeing to it that the projectors are maintained in first-class condition and that the projectionists are thoroughly trained in the correct methods of handling the film during the projection and rewinding processes.

Supervision involves not only an effort to eliminate all possible defects in the equipment but also an attempt to reduce to a minimum the chances of mistakes in presenting the show to the audience. For this reason, it is essential that the Supervisor initiate a routine which will include a complete outline of the duties of each projectionist, making certain that this includes some method whereby a reel can be readily identified *after* it has been threaded into the projector and before actual projection. A sticker carrying the name or the number of the reel attached to the film where it passes over the hub of the take-up reel is one convenient method of accomplishing this.

A word should be said regarding the Supervisor's relations with the projectionists under his supervision. By his example and instructions he can promote higher standards and more careful work on the part of the projectionists. By giving heed to their reasonable requests, he can maintain their active coöperation in presenting perfect shows. Conversely, if requests for needed materials or repairs are ignored, it need not be wondered at if the projectionists soon develop an attitude of indifference. Obviously, the Supervisor can not be present in each theater during all the hours of operation and consequently he must rely upon the coöperation of the regular projectionists in calling his attention to any undesirable condition in the equipment or in the performance which might otherwise escape attention. In connection with this, it is very helpful to enter a record of such instances in a log-book kept in the projection room for the purpose and available to be consulted whenever inspections are made. Other helpful aids are written records covering spare parts, materials required, and (when they have been received) also wiring diagrams, which may be posted on the projection room wall, these indicating the size and the location of every fuse, switch, or circuit-breaker in the projection and sound feeders. In checking up on theaters, it has been discovered that one of the most frequent defects which are found has been the misalignment of the projector light-source with the other components of the optical system. When this condition has been corrected it has resulted in greatly improved screen illumination.

In many localities theaters are obliged to purchase electric service from companies which, in computing their rates, take into considera-

tion the maximum wattage (or "demand") used at any instant during the monthly billing period. Under such a system, the greater the maximum wattage used by the theater, the higher the rate for each kilowatt hour. In such a situation it becomes doubly important to install equipment that will provide sufficient illumination on the screen and which at the same time will operate so efficiently that the wattage drawn from the power lines is held at a minimum.

In conclusion, supervision provides the only means the exhibitor has at his disposal to protect his most important asset, a reputation for giving high-quality performance. It is the only means available to him to protect his equipment against excessive deterioration and frequent breakdowns. It should not, therefore, be regarded as a needless expense but rather as an invaluable and indispensable necessity.

THE PROJECTIONIST'S INTEREST IN AUDITORIUM VIEWING CONDITIONS*

B. SCHLANGER**

Summary.—Auditorium viewing conditions and screen considerations should justly be the concern of the projectionist. The following factors beyond the confines of the projection room should be of interest to him: (a) screen size, (b) screen lighting, (c) screen border, masking, and immediate surroundings, (d) position of screen.

The paper discusses these items, giving recommendations that should permit the projection of high-quality motion pictures.

If the projectionist intends to carry out his work successfully, he must realize that the scope of his work does not begin and end with the operation and care of the electromechanical projection equipment. There is much more detail to be considered that can be found beyond the confines of the projection room which will affect the quality of the picture presentation. Auditorium viewing conditions and screen considerations should justly become the concern of the projectionist because any compromise in the quality of the presentation will only diminish the effect of the good work he otherwise performs. It is not necessary to increase the amount of work performed by the projectionist to broaden the scope of his work; it is suggested merely for him to be observant of the conditions he is given to work with and to report to his superior all existing deficiencies. By the time the projectionist appears on the job it is usually too late to make fundamental changes in auditorium design and lighting, but the projectionist may be able to point the way toward making the best of what he is given to work with. Glaring errors may be corrected without too much difficulty in many instances because of some advice given by the projectionist. Exhibitors could thereby, through their projectionists, be

* Presented at the 1940 Spring Meeting at Atlantic City, N. J.; received April 15, 1940.

** New York, N. Y.

made conscious of better projection and in turn eventually be guided in building more scientifically correct auditoriums.

The following considerations beyond the confines of the projection room seem to be of direct concern to the projectionist:

- (a) Screen size.
- (b) Screen lighting.
- (c) Screen border, masking, and immediate surroundings.
- (d) Screen position.

While acoustics and seating arrangements may also add or detract from the work of the projectionist, he can not do much to change conditions in these instances and neither can he be equipped to deal with such detailed specialized work. But it is his duty to point out those faults which may come to his attention in regard to these aspects. There is much work now being done to determine the requirements for desirable auditorium viewing conditions, but until such time when definite standards will be established, it is possible for the projectionist to make recommendations which will at least correct such conditions which are definitely known to be undesirable.

Although an attempt will be made here to give information to the projectionist as to the faulty conditions which are to be avoided, it should be pointed out that more detailed information should be made available to him so that he may improve his service to the best possible extent. Tolerable ranges and other recommendations for items *a* to *g* given below will be of use to the projectionist if intelligent application of the information is applied. For example, the proper selection of a screen size taken from within the recommended range of sizes given depends on the possible treatment and provisions which can be made for the other listed considerations. Following is a list of recommendations and suggestions for their practical application:

(a) *Screen size*.—A width no greater than or less than dimensions calculated by using the divisors from 5.2 to 5.8 with the distance from the screen to the last row of seats being the dividend.

(b) *Screen Lighting*.—Ten foot-candles of incident light or more measured as an average lighting for the entire area of the screen, allowing a maximum differential of thirty per cent between the edge of the picture and the center portion.

(c) *Screen Border, Masking, and Immediate Surroundings*.—The screen masking is a light-absorbing band of material placed at the extreme edge of the picture on all four sides for the purpose of eliminat-

ing the appearance of the fuzziness found at the edge of the picture.

The screen border is a band of material forming a frame around the picture immediately outside of the making frame. This material need not be light-absorbing or dark in color. Its relative size, color, and degree of darkness vary in accordance with the auditorium design and the particular approach made as to the psychological aspects of the picture presentation. Various types of illuminated screen borders are being experimented with.

The immediate screen surroundings constitute those ceiling and wall surfaces which come within the range of vision of the patron while viewing the picture. These surfaces should have a finish and color which will control the amount of light re-reflected from the screen. They should also be uniform in texture and without surface breaks or painted decorations which would create shadows or contrasting areas of reflected light. There should not be any spots or isolated areas of secondary illumination on these surfaces. The aim here is to create a neutral and undisturbing setting for the projected picture.

(d) *Screen Position.*—The screen should be centered in relation to the seating width and not to the physical width of the auditorium structure. A maximum possible distance is desirable from the screen to the first row of seats. The distance between the floor and the bottom of the picture is subject to the relationship between the picture size and the distance between the first row of seats and the screen. Six feet is a maximum from floor to picture bottom when the picture width is equal to the distance from the first row of seats to the screen. This height may be increased 2 inches for every increase in distance from the first row to screen equal to one-eighth of the picture width.

(e) *Screen Material.*—Durability, efficiency in light reflection, degree of light diffusion, and sound transmission are the factors controlling the selection of proper screen material. Screen costs should be considered as to the cost per year rather than by the initial cost. Resurfacing of screens should be limited to one time. Where screens are especially subject to atmospheric discoloration it is desirable to use a screen material inexpensive enough to warrant frequent replacements. For example, there is now available a satisfactory paper screen which would suit such a purpose.

The considerations listed under *a*, *b*, and *c* are definitely related to one another. For example, the minimum amount of incident light recommended on the screen would apply to the ratio given as 5.2

under the *a* heading, the amount of incident light required under higher ratios being greater in proportion to the increase in ratio.

The above ratios also control the width of the masking explained under heading *c*. This width should be an absolute minimum unless the ratio happens to be 5.3 or less. The width can be as little as 3 inches to destroy edge fuzziness. Larger masking widths tend to make the picture appear small from the rear half of the seating. Wide maskings are especially undesirable when colored films are projected.

The screen border referred to replaces the area normally occupied by dark masking material. It is especially desirable when the picture width is $\frac{1}{2}$ or less than $\frac{1}{2}$ of the auditorium width and when the ratio heretofore mentioned is 5.3 or more, such instances in which auditorium proportions tend to diminish the apparent picture size.

A PERSONAL SAFETY FACTOR FOR PROJECTION PRACTICE*

T. P. HOVER**

Summary.—The dangers inherent to the projection of nitrocellulose film are so obvious, and the accidents, when they occur, are so spectacular that practically no attention is given to other hazards in the projection room. This is to be expected in an industry where practically no knowledge concerning the equipment and its operation ever appears to the outside world. Only the joint coöperation of the manufacturer of equipment, the sound supervisor, the theater manager, the projectionists, and intelligent public safety officials can make the profession of projecting motion pictures a safe one. Some of the observations of the author, who is closely associated with safety officials in the State of Ohio, are given in the paper.

The increasing age level among the skilled craftsmen in the motion picture industry and the addition of many new industrial hazards within the past few years, suggest that added consideration be given the physical well-being of these workers. The spectacular effects following a film fire are often so outstanding that this single item has received attention in safety engineering almost to the entire exclusion of all other types of hazards.

In planning a course of education or instruction in safety, the most successful approach in most industries is through the largest and most energetic group of employees. Unfortunately, this is not the case in the motion picture industry, since to expect assistance from the theatrical unions is to expect the impossible. Year after year, these unions supply skilled craftsmen who work under conditions which in many cases are extremely unhealthful, without making vigorous protest against such conditions. It therefore is not likely that these organizations would be interested in demanding installation of safety appliances which might save a projectionist's thumb, conserve his eyesight, or perhaps even such an unimportant item as his life.

The problem may be roughly divided into four parts, falling, respectively, under the jurisdiction of the manufacturer, the exhibitor,

* Presented at the 1940 Spring Meeting at Atlantic City, N. J.; received April 20, 1940.

** Warner's Ohio Theater, Lima, Ohio.

the sound supervisor, and the projectionist. I shall make no attempt to present a complete safety survey, but will point to outstanding examples of danger, in the hope of starting some original thought concerning this important problem.

(1) *The Manufacturer.*—The trend now is to remove much of the so-called bootleg equipment from the market. This is in the interest of safety, since a large part of this equipment contains elements tending strongly to decreased safety in operation.

A few states and some municipalities have far-sighted public-spirited officials, endowed with the proper authority to ban certain types of dangerous equipment. Nevertheless considerable equipment has been installed in projection rooms with apparently but one idea in mind by its manufacturer, namely, that it will hold together long enough for him to collect its cheap price. That such cheaply constructed equipments often constitute a hazard to the projectionist apparently has not entered the mind of anyone.

There can be no possible excuse for unprotected chains, gears, or flywheels anywhere on a modern projector. Manufacturers supplied a real aid to the projectionist when they installed a handwheel on the drive or motor shaft, but in many cases this wheel is knurled or has exposed set screws which can catch any clothing which might touch it. A friction coupling could be used.

There is no particular reason why oil holes concealed within a maze of gears can not be piped to the outside or to a convenient place on the projector, except the cost of so doing, and such cost would not be at all high.

Idler rollers and roller assemblies should be so designed and placed that when open they provide a clearance of at least five-eighths of an inch all around the sprocket. If for any reason this is not practicable, they should be placed so that they will not open more than one-eighth of an inch from the sprocket. Rollers which provide clearance between these dimensions will permit a finger to be caught by the sprocket teeth and either seriously mangled or broken.

Necessary projections extending out from the base of the projector should be enameled white to prevent tripping in a poorly lighted projection room. Much annoyance and even serious accident has been caused by failure to do so.

The poor eyesight so common among older projectionists is to a considerable extent due to carelessness and ignorance. Many projectors were planned and constructed in such a manner that light is

spilled over from lamp house, condenser housings, and aperture plates. There can be no possible excuse for any of these hazards existing in a modern projection room.

Not all hazards are confined to the moving parts of the projectors. For many years lamp manufacturers were beset with what were variously called, "the Chicago regulations," "the Massachusetts regulations," and the "Ohio regulations," *etc.* Some of these efforts by state and municipal authorities were sincere but misguided. Others were simply the result of a trend in thought produced by some accident or mishap which received considerable attention at the particular time. Many ill-judged laws, so originated, are still in full force.

For example, one municipality still requires a bucket of sand in the projection room. Unfortunately, a full bucket of sand is so heavy that under conditions when split seconds count, the weight of the bucket prevents its rapid manipulation; hence it is seldom used, but serves to prevent adoption of some other sensible ordinance.

Another city enforces an ordinance requiring that a water barrel be maintained in every projection room, though nothing is said concerning the contents of this barrel. I might add that many projectionists use it as a receptacle for waste paper and film scraps.

Not all these ordinances and regulations were foolish, however. Lamp houses having the vents covered with a fine mesh wire were an assurance that sparks could not escape from the lamp house. This was really a safety measure in the days when less than one-third of the theaters provided proper ventilation for lamp houses, and, incidentally, not all theaters have it today. Another regulation required the careful shielding of commutators and brush holders of motors of generators located within the projection room, which regulation is as necessary today as it ever was.

The mad scramble to place simplified high-intensity arc equipment on the market has resulted in some mechanical and electrical concoctions which normally might receive the attention of a museum. There can be no excuse for the construction of a lamp housing which can or will permit hot carbon or slag to fall out. A ruling in effect in many cities prohibits the lamp manufacturer from bringing arc leads up through the bottom of the lamp, especially if these leads are of any length. A burned-off lead could easily fall through the bushing and touch the metallic portion of the projector or the floor, thus forming a very real hazard.

It would appear, from close observation of some of the lamps today on the market, that a little attention might well be devoted to the study of convection currents and the action of heated air and fumes, with the probable result of less solid material deposit in the lamp house and the moving machinery within it; with a resultant improvement in the health of the projection profession.

There is no reason to believe that a powdery deposit which will gradually work injury to the gears and bearings of the equipment will be beneficial to the lungs and respiratory passages of a projectionist. A projectionist may be better than his equipment, but it is unlikely that he is tougher.

Finally, a manufacturer's practice of some years ago deserves some attention: namely, the issuance of carefully written instruction books for the various types of equipment placed on the market. For the manufacturer to assume that the projectionist who will handle his equipment is skilled and capable of operating it at greatest efficiency is flattery at its highest. But a well written instruction book will certainly increase general efficiency and assist the projectionist who may have been absent when the equipment was installed or demonstrated. Some manufacturers of radio and sound equipment make a practice of soliciting information from outstanding engineers which will aid in the operation of the equipment they sell. As compensation, they frequently donate the piece of equipment to the engineer writing the most satisfactory text and instruction book.

It should not be thought that the entire industry is lax in this matter. Certain manufacturers have been active in this type of work from the very start of their business. It is safe to say that the preference for their equipment by projectionists all over the world probably had its inception after their contact with some of the educational features of these companies.

(2) *Sound Supervisors.*—The sound supervisor is in a position where he can readily aid the projection staff in matters of personal safety.

Starting at the projection room door, especially those reached by steel steps and ladders, a door mat of carpet or felt may require an occasional sweeping to keep it clean, but it will also remove any slight film of oil which might get on the projectionist's shoes. It is an accepted fact that a slight quantity of oil on rubber soles or heels will provide danger of slipping on steel ladders or steps.

No sound supervisor should permit the installation of conduit on

the floor where the projectionist must step over it, or overhead where it may contact his head. Any number of faults might be pointed out—nails are frequently driven into walls for the purpose of hanging tools or clothing, and an unsuspecting person may stumble into them and receive serious injury.

The sound supervisor should pay particular attention to gadgets which the inventive projectionist may add to the projection room or its equipment, making sure that, if electrical, they comply with municipal ordinances; and, if mechanical, they do not result in a menace to life and limb.

One item should receive the attention of every sound supervisor: namely, some means should be found to light the stairways and ladders leading to the projection room amply before the house lights in the theater are turned on. An astonishing number of serious injuries occur where the projectionist must literally feel his way to the house-light switch, which often is in the projection room. The practice of one supervisor in placing a low-wattage lamp outside the door of the projection room in most of the theaters under his supervision is to be highly commended.

(3) *The Exhibitor*.—The exhibitor should be vitally interested in the health and physical welfare of his projection staff. In a country where almost every state has some type of workmen's compensation in the event of injury or death resulting from accidents, the ultimate cost rests, sooner or later, upon the exhibitor himself. In some cases the neglect and carelessness is so obvious and criminal that law suits have resulted, usually to the disadvantage of the employer. It should be remembered that a man on crutches, or well plastered with bandages, has a distinct advantage in the average court of law. The fact that an exhibitor may have workmen's compensation or liability insurance does not make him immune to court action in cases where compensation and examining boards rule that the accident in question was the result of criminal carelessness on the part of the employer.

It is only fair, at this point, to compliment those employers who have made available sickness and accident insurance at a reasonable rate. Some welfare organizations sponsored by various circuits deserve commendation. In some cases they have been directly responsible for saving the lives of theater employees who would be unable to afford expensive medical attention.

The exhibitor, being in almost daily contact with his projection staff, should realize that a man who delivers careless and sloppy pro-

jection will have these same habits in matters of personal safety. Certain employees develop a tendency toward accidents, and carelessness is usually at the seat of this habit. It is an established fact that accidents, regardless of where they may happen, are not equally distributed among the population. A small part of the population has a large part of the accidents.

The use of open or desk-type fans anywhere in the projection room should be absolutely forbidden. If a proper ventilation system has been installed, such fans are useless. They bring with them not only the danger of someone reaching into them in the darkened projection room, but the drafts which they create stir up dust and grit which can collect on optical systems, film, and in the gears.

Several fatal accidents among projectionists bring up another important point—the use of various solvents in the projection room. There can be no excuse for anyone's bringing gasoline or kerosene into a projection room. Each year one or two theater employees take this means of leaving the movie industry. There are a number of satisfactory cleaning fluids on the market which are entirely free from the danger of explosion, but it should be remembered that all commercial solvents available at the present time give off fumes, which, under the increased temperature and doubtful ventilation of a projection room, may impair the health of the employees. The use of benzol products should be particularly condemned, for they are not only highly explosive, but may do serious damage to the heart and respiratory passages when inhaled.

(4) *The Projectionist*.—Projectionists should use great care in replacing guards, cut-out switches, and various safety appliances which have been furnished by the manufacturer. Strapping out safety switches on power amplifiers and other high-voltage equipment may not endanger the skilled electrician who works with this type of equipment every day, but nevertheless it may cost the life of the assistant or relief projectionist who may not be entirely familiar with the equipment, or with the fact that voltages in excess of seventy may cause instant death. There are on record cases of deaths resulting from contact with the power circuits of ordinary household radios using voltages less than those used to supply sound picture amplifiers.

Any local union that claims to have bettered the welfare of its members should be able and willing to add this statement to its list of achievements: namely, that every projectionist member and stage electrician shall have a working knowledge of, and be able to ad-

minister, the Shaeffer Prone Pressure Method of Artificial Resuscitation. Numerous films have been made demonstrating this system and there is no reason why every active worker in the projection field should not be familiar with its application.

The Red Cross provides a program of first-aid instruction which is practically in continuous operation in cities of any size in the United States. An eight-hour course of instruction may be had at the price of the text-book, which is usually 60 cents. At least one employee of each theater should be a graduate of this course. Most theater managers are ready and willing to furnish proper first-aid kits to their projection staffs, but only too often the adhesive tape takes its place in an electrical circuit while the bandage materials are allowed to collect dust in the open air and the iodine is permitted to evaporate.

It should be pointed out that many of the ills that beset the projectionist are the result of his own carelessness or lack of expert knowledge. It is to be hoped that a proper spirit of coöperation will not only result in saving of life and increasing efficiency in projection, but will stave off the inevitable day of reckoning when increased and prohibitive insurance rates will compel attention to proper safety principles or prohibitive legislation and regulation will add one more burden to an industry now sadly overburdened and overregulated.

It is safe to say that few industries spend so much time, attention, and money in maintaining their physical equipment at peak efficiency, but there is no other industry which pays so little attention to the personal health and welfare of its skilled workers.

In the State of Ohio, employers and employees alike have for many years been taught that accidents do not just happen, but are the result of doing something the wrong way. The State of Ohio has no copyright or patent upon this statement which I can heartily recommend for use in the motion picture industry.

DISCUSSION

MR. RICHARDSON: What is your idea as to what proper lamp house ventilation should be?

MR. HOVER: It is not the duty of a projectionist to tell the lamp manufacturer how to build his lamps. However, there is one lamp in particular that has a habit of spewing out gobs of melted slag on the floor.

The lamp manufacturers are certainly working to the limit to put out good products, and these minor features should be brought to their attention. I find that they are almost always cured in a very short time.

Case material regarding any type of industrial accident is extremely difficult to get. The tendency of employers to cover up and minimize accidents is often the result of guilty conscience, and this activity, rather than curing the cause, usually results in additional carelessness or inattention to various hazards.

Through close contact with the Industrial Commission of the State of Ohio over an extended period of years, I have been able to check many case histories and pick out those hazards which seemed outstanding.

DEFECTS IN MOTION PICTURE PROJECTION AND THEIR CORRECTION*

IRL GORDON**

Summary.—The defects in projection caused by oil and dirt on the film are discussed at considerable length, with respect to the appearance of the screen images of the following groups of prints: (1) toned print; (2) light or high-key prints; (3) color-film; (4) very dark prints. The seriousness of the defects caused by oil in the four groups is in this order.

The causes of oil on film are discussed in considerable detail, and suggestions are made for alleviating this situation.

Control of the flicker evil has had much attention from the industry. Flicker caused by shutters, light fluctuation, and uneven photography has been investigated, and progress has been made on the elimination of each. But today there still exists an evil which has been with us since the first release print. It is the evil of oily film, which is becoming more and more noticeable through the adoption of more brilliant light-sources and high-key photography.

It is essential to good projection that the film be clean, since every defect is highly magnified, and any deviation from perfect cleanliness is detrimental. Perhaps the most commonly recognized indication of oily film is the travelling "frame-line effect," so noticeable with the high-key prints. A lighter area, the width of a frame line, starts from the bottom of the screen, and travels slowly to the top

* Received March 1, 1940.

** Forum Theater, Akron, Ohio.

This is surrounded by a darker flickering area superimposed over the entire picture.

All oil patterns are not of such a well defined shape. They vary from frame to frame and depend in extent upon the amount of oil on the film at that moment. The pattern changes from one rewinding to another. It always shows on the screen as a crawling, spotty effect which may move from bottom to top as the "frame-line effect," or horizontally as a dancing effect. It may even appear as a wavering mass of flicker. If the film is light or toned, the effect is very pronounced, due to the contrast between the oil spots and unaffected areas.

If oil is present on the film in a thick layer the image becomes blurred, causing an out-of-focus effect. This type of oily film shows a strong tendency to buckle under heating. The alternate sharpness and blur of the image, combined with "mass flicker effect," are very tiring to the eyes, and with the long show times of double-feature bills, running from three hours upward, sets up a condition discussed by Snell, namely, "Anything causing difficult seeing will result in eye-strain."¹

The combined action of all the various types of flicker caused by oil spots, constantly changing position over a period of hours, most certainly must affect the eyes of the theater patron and mar his enjoyment. Almost all films, after the first and second runs, have some oil on their surface.

Various kinds of oil are used for lubricating motion picture projectors. Some are thin and fairly transparent; others are of a heavy, sticky automobile type used under the mistaken impression that they will cling to the bearings longer. When any oil is on the film, dirt, dust, and bits of grit are picked up and lodge along the path of the film in the projector, or cling to the rotary stabilizer drum of the sound-head thus constituting a prolific cause of scratches. If the emulsion with all this dirt, which acts as an abrasive, happens to "skid" while rewinding, fine scratches occur which soon fill up with dirt and show on the screen as a form of "rain."

Once oil is on the print, it is a difficult job to remove it without proper cleaning machines. The mere wiping of the film with a rag moistened with cleaning fluid will not do much good, since in a very short time the rag becomes so dirty it merely smears the accumulated dirt over a larger area. Very few theaters have installed cleaning machines.

Film images may be classified broadly into four groups accordingly as they show oil spots, as follows:

(1) The first and worst is probably the toned print, and the most seriously affected of this type is the brown toned film. Indeed if a liberal dose of oil is present, the result is so very annoying that it will detract from the dramatic value of the story in spite of concentration on the part of the observer. We have had many complaints of "something wrong with the picture," when showing this type of print. "Frame-line effect" and "mass movement of oil" stand out very clearly.

(2) The next is the print in the light or high-key, containing very light scenes, outdoor western shots, and scenes in which there are great areas of low density. "Frame-line" and "mass" effects predominate. Dirt and scratches show plainly. Cartoons are included in this group.

(3) Color-film comes next. With some scenes, the oil causes a fuzzy appearance; on the lighter scenes "frame-line" and "mass" effects are very annoying. In only a few instances, however, does the oil appear to change the color values. However, with the trend to lighter color prints the oil evil is becoming more troublesome, because on the dark prints of the past the oil spots did not show up so plainly as explained below.

(4) Probably the least affected are very dark prints, in which even the highlights are grayed considerably. These are called "low-key" prints. Oil on this type shows only as a mass effect in the lighter portions of the scene, causing a wavering effect. The tendency for the emulsion to become scratched seems greater, which may be accounted for by the fact that the emulsion appears to be softer when much oil is present. If oil happens to be present in considerable quantity the image seems to change color. Dense prints are difficult to project in any event, and the addition of oil and dirt further reduces the brilliancy of the screen image. Some tendency to buckle has been experienced with oily dark prints, though this can not be stated as the general rule.

Oil gets on film in various ways. A new print will begin to show signs of oil along the left side within a short time. With the new print, poor waxing or treatment before showing is one reason why the print is often "directly oiled." A new print as received from the exchange has been either waxed or treated. The first time through the projector everything is fine. After three or four showings, however,

trouble very often starts. Usually during the evening show on the opening day the print begins to stick. Late-model projectors have means for tension release, but tension has to be so loose that the screen image will jump, and rather than face a bill from the exchange for strained perforations or have a jumpy picture, the tension is eased up a little and oil is poured on the perforation track, which in successive runs spreads over increasingly large sections of the film. Quite a number of first-run projectionists have felt obliged to resort to this oiling practice at some time or other. As to the relative merits of the various film treatments with respect to preventing oil spotting I have no reliable data, but do know that sticking occurs with all of them on occasion.

The most common path of access to the film is through contact of the film with oil in the projector mechanism, particularly near bearings or intermittents, and in sound-heads. Worn bearings, leaks at the intermittent and over-oiling cause oil to be smeared over the interior of projector and sound-heads, often causing pools of oil to be formed. Gears throw off oil which drains and seeps through crevices, often running down the magazines, to drop either in a pan or directly upon the floor under the lower magazine causing an oily area which collects dirt and dust. In threading, the leaders are dropped on the floor, gathering this oil and dirt. The first two hundred feet of a film are always oily and dirty, tending to make change-overs noticeable. The oil is carried by the back of the film, sticks to the rotary stabilizer drum in the sound-head, and is distributed over additional areas. As a result of rewinding, the oil and dirt are spread along the film until finally they are present from end to end of the reel.

The complete abolishment of the oil evil will be a difficult task. It requires careful study and coöperation by all concerned: everyone from producer to projectionist, including equipment manufacturers. Such evils lower entertainment values and, in the last analysis, detract from box-office income; hence everyone connected with the industry is affected. People tire of attending theaters where the screen fare is marred by flicker and the sound reproduction punctuated by pops, cracks, and unevenness caused by oil and accumulated dirt. With each new advance toward a brighter screen image, the defect becomes more visible, and the time to effect eradication of it is right now.

The theater can do its part by providing the necessary rags, cleaning materials, and working conditions (some projection rooms boast as much as one rag a month). Above all, theater managements

should insist that exchanges supply cleaned prints. Projectors should be kept in good repair and a fair amount of supervision exercised by the theater managers to see that the projection room is kept clean. Reports of film conditions should be kept and action taken when necessary, instead of merely filing the report against the time when the exchange might complain about film damage. The coöperation of the projectionist should be sought and encouraged, to get the best possible screen image and sound quality at all times. I wonder how many exhibitors, if they were in the automobile business, would drive a mud-spattered car before potential customers, yet they permit parading of oil-soaked films before their regular customers expecting them to like the show and come back for more.

The manufacturers of motion picture projectors should investigate ways of eliminating oil seepage, even going so far as to make something foolproof if necessary. Grease-packed bearings, roller or ball bearings, or better sealing of existing bearings might be considered. Due to the excessive projection angles, much over-oiling takes place when it is attempted to keep oil in the top parts of the bearings. Sound-heads should be drilled to drain any oil that might collect, and some simple oil-catch, flexible enough to fit the older projectors, should be made available. Some of the existing oil-pans and drains will not fit older sound equipment now in use. By using a lighter color for the projectors the oil and dirt would show up, and through pride the projectionist would be led to keep his equipment cleaner. The black now used does not show the oil and dirt plainly and tends to cause neglect.

Exchanges should seek better green film treatment and should clean prints after each booking; also schedules should be worked out to stop the circuiting of prints from theater to theater with no inspection or cleaning. Sufficient additional prints should be issued if bookings are heavy. In one instance a print started in a first-run house and was passed on through seven houses before it went back to the exchange. This was regular practice. It was weeks before the print reached the exchange. Further study should be given the treatment of toned prints, and probably some work done on an oil repellent to coat all films. Crabtree and Ives² in 1927 suggested that toned prints be treated with a solution that would fill up the pores in the surface of the toned film and thus repel the oil to a great extent. So far as my memory goes, I have never received a print treated in this manner.

If oil were of a brilliant color, it would be so noticeable that it would not be long before steps would be taken to deal with the situation; but since it is semitransparent, its effects are not fully realized. It will take extensive education and vigilance to cope with the evil. Film goes into all kinds of projection rooms, some dirty, others clean, but by the use of reports, education, and vigilance, it may soon become apparent who are the worst offenders so that steps can be taken to eliminate the source. Only then will the projectionists in the smaller theaters be able to give the patrons excellent projection equal to that in the first-run houses.

REFERENCES

¹ SNELL, PETER A.: "An Introduction to the Experimental Study of Visual Fatigue," *J. Soc. Mot. Pict. Eng.*, XX (May, 1933), p. 367.

² CRABTREE, J. I., AND IVES, C. E.: "Lubrication of Motion Picture Film," *Trans. Soc. Mot. Pict. Eng.*, No. 31 (1927), p. 522.

RECORDS FOR THE PROJECTION ROOM*

J. R. PRATER**

Summary.—Some portions of the data necessary to good projection room records may be kept to the best advantage on blank forms. Examples are shown of such blanks adapted to (1) an inventory of projection room supplies and spare parts, (2) data on vacuum tubes, (3) exciter lamps, (4) film inspection, and (5) a cue sheet. Noteworthy features are discussed, and suggestions given for adapting these forms to individual projection rooms. Projectionists will find it easier to keep good records on appropriate forms than it is to get by without them.

The keeping of detailed records in the theater projection room is essential to efficiency and to excellence in results produced. Exhibitors and theater managers who care for efficiency; who wish to achieve the best results at the lowest cost should provide proper blanks for keeping such records, preferably in the form of sheets so perforated that they may be bound in loose-leaf binders and thus retained for future consultation, the value of which latter should be evident.

* Presented at the 1940 Spring Meeting at Atlantic City, N. J.; received March 1, 1940.

** Congress Theater, Palouse, Wash.

PROJECTION ROOM SUPPLIES AND SPARES													
MINIMUM STOCK TO KEEP ON HAND	ITEM	JAN., 19			FEB., 19			MARCH, 19			APRIL, 19		
		ON HAND JAN.	REPLACEMENTS	AMT. USED	ON HAND FEB.	REPLACEMENTS	AMT. USED	ON HAND MARCH	REPLACEMENTS	AMT. USED	ON HAND APRIL	REPLACEMENTS	AMT. USED

VACUUM TUBES														
DATE _____ TESTED BY _____														
TYPE	IDENTIFICATION NUMBER	BRAND	DEALER	COST	DEALER'S TEST	NORMAL PLATE CURRENT WITH GRID SHIFT	P.C. DIFFERENCE	DATE INSTALLED	WHICH SOCKET	DATE REMOVED	HOURS USED PREVIOUSLY	HOURS USED THIS TIME	TOTAL HRS. USED	REASON REMOVED

EXCITER LAMPS								
LAMP NUMBER	BRAND	DEALER	COST	DATE PUT IN ACTUAL USE	WHICH PROJECTOR	DATE DISCARDED	HOURS USED	REASON DISCARDED

FIG. 1 (Top). Record chart for projection room supplies.
 FIG. 2 (Center). Chart for vacuum tubes.
 FIG. 3 (Bottom). Chart for exciter lamps.

Certain equipment parts are subject to heavy stresses. They wear out and must be replaced with comparative frequency. With a record of the terms of service given by such parts the management is in position to select those brands that the record shows have provided the most efficient service.

Keeping such records involves a bit of extra work for the projectionist, but one who has real interest and pride in his work will not object. Instead he will be more than repaid for the labor involved by the assistance these records will afford him in his work. Keeping such records is a legitimate part of his work.

Appropriate blank forms will be of real assistance in keeping much of the necessary record data. Perforated sheets suitable for binding in a loose-leaf cover may be had at nominal cost at any good stationer's store. The projectionist may rule and head the blanks himself, especially those not used in large quantities. However, since the keeping of such records is definitely to the advantage of the theater operating cost, the exhibitor should be not only willing but eager to supply printed forms.

Supplies and Spare Parts.—Fig. 1 shows a compact blank for keeping an account of all projection room supplies and spare parts. It is based upon the assumption that a complete check-up of supplies will be made on the first day of each month, which certainly represents good practice. Provision is made for listing the least amount of each item that should be kept on hand for the coming month plus time required to obtain replacements. Comparing this amount with the actual stock at each check-up enables the projectionist to order a full month's supply at one time without danger of omitting necessary items and thus incurring risk of running short. This form may be made up on sheets large enough for several months, to avoid copying the names of all items every month. Perforated sheets to fit the regular looseleaf binder may be used, or bound pads already ruled with enough columns to serve for a whole year may be had at stationers at nominal cost. In either case, a permanent record would be available enabling computation of the cost of each item at the end of the year. The value of such a record increases the longer it is used.

Vacuum Tubes.—Fig. 2 shows a blank for charting vacuum tube data. This sheet will serve for all types of tubes in use. A new blank should be filled out at each complete tube check-up. The time between regular inspections will depend upon the number of hours the theater operates each day; also somewhat upon the class

of performance it must maintain. Since the normal useful life of most vacuum tubes is about 1000 hours it is well to check them at least once every 500 hours. Replacements or changes made between regular check-ups may be recorded on the previous blank. Where the same type of tube is used in different stages of amplifica-

FILM INSPECTION REPORT																		
THEATRE _____		CITY _____		STATE _____		DATE _____		INSPECTED BY _____										
TITLE	EXCHANGE	RUNNING TIME	RECEIVED FROM	STARTING LEADER		SOUND TRACK	SPROCKET HOLES	SPICES		GENERAL CONDITION		CUE MARKS						
				SPICES	MISFRAMES	FOOTAGE MISSING	SPROCKET HOLES TORN	SCRATCHES	SPROCKET MARKS	STRAINED	STRIPPED	TOTAL NO. IN PICTURE	UNSAFE	MISFRAMES	OILY	DIRTY	SCRATCHES	EDGE BREAKS

CUE SHEET							
SUBJECT	REEL NUMBER	RUNNING TIME	THREAD ON	VOLUME	ARC CUE	CURTAIN CUE	MOTOR START

FIG. 4 (Upper). Film inspection report chart.

FIG. 5 (Lower). Cue sheet.

tion, different readings may be obtained with the same tube; hence all spares should be tested in the same socket to give proper readings for comparison. A column is provided for carrying forward the number of hours a tube has already been used in case it will be re-matched and returned to service. In addition to providing data necessary to proper choice of tubes, including emergency replacements, this chart enables the projectionist to determine what brand of tubes serves his

needs best. While the price of tubes is now so reasonable that this item alone is relatively small, it is definitely an advantage to use tubes that may be depended upon to give satisfactory operation for the longest possible time. Otherwise more frequent check-ups are necessary and faults more likely to develop between them.

Exciter Lamps.—A similar and simpler blank shown in Fig. 3 serves for keeping a check on exciter lamps. Like vacuum tubes the lamps themselves are inexpensive, but a burn-out during a performance must be carefully guarded against. At the same time, there is nothing to be gained by discarding them too soon when it is so easy to keep a record that will show when they have completed their expected life.

Film Inspection.—Fig. 4 shows a blank especially adapted to projection room film inspection. Such a report turned in to the theater manager is proof of the condition in which prints are received. A copy of such report mailed to the exchange before the show opens, or as soon thereafter as possible, is excellent insurance against unjust claims for damage. The blank provides for separate consideration of starting leader, sound-track, sprocket-holes, splices, and cue marks, in addition to the general condition of the film as a whole. The most common faults met with are listed in the headings, thus enabling the projectionist to make a reasonably complete record merely by indicating whether the fault exists; or, if present, the amount thereof; and to do this with a minimum of exertion. The section devoted to cue marks has a psychological value worthy of mention. After reporting the existence of punch holes, scratch marks, grease pencil smears, click patches, *etc.*, month after month, the projectionist who has pride in his work will not feel inclined to inflict additional damage by making change-over marks of his own.

Cue Sheet.—A cue sheet similar to Fig. 5 may be used, instead of making cue marks on the film. Threading marks, arc cues, and curtain cues are seldom the same in various theaters. After several projectionists put their own marks on the film, each in a different place, picking out the one you want is quite a guessing game. And, after all, there is little satisfaction in putting on a smooth performance if the cues themselves damage the show.

It is hoped that projectionists will give blank forms similar to these a fair trial. It may be necessary to use a few hand-made blanks, and to work out any changes needed to fit them to individual needs before asking for a supply of printed forms.

STEREOPHONIC REPRODUCTION FROM FILM*

HARVEY FLETCHER**

Summary.—On April 9 and 10, 1940, demonstrations of the stereophonic reproduction of music and speech, described in the accompanying article, were given at Carnegie Hall, New York, N. Y. This represented the latest development in a series of researches by Bell Telephone Laboratories, the first step of which was demonstrated in 1933 when a symphony concert, produced in Philadelphia, was transmitted over telephone wires to Washington, and there reproduced stereophonically and with enhancement before the National Academy of Sciences.

For the present demonstration, original recordings of orchestra, choir, and drama were made at Philadelphia and Salt Lake City; and at a later audition the artist or director was able to vary the recorded volume and to change the tonal color of the music to suit his taste. At will, he could soften it to the faintest pianissimo or amplify it to a volume ten times that of any orchestra without altering its tone quality, or he might augment or reduce the high or low pitches independently. The music or drama so enhanced is then re-recorded on film, with the result that upon reproduction, a musical interpretation is possible that would be beyond the power of an original orchestra, speaker, or singer to produce.

Symphonic music heard over radio or the loud speakers of sound-picture systems, although very satisfactory, fails to produce in several respects the effect received by one listening to the original production in an auditorium. A full symphony orchestra utilizes air vibrations at nearly all the frequencies the ear can hear, and it uses volumes of sound from about the lowest that can be heard in an ordinary auditorium to volumes one hundred million times greater. The frequency range of such an orchestra, in other words, runs from the neighborhood of 40 cycles per second to perhaps 14,000 cycles, and the volume range extends from about 30 db above the threshold of hearing to 110 db, a total range of 80 db. In contrast with these ranges, radio and sound-picture systems usually have frequency ranges only 5000 to 8000 cycles, and volume ranges from 35 to 50 db. Moreover a listener in an auditorium receives an added effect from the distribution of the sound in space, a recognition of different sounds coming from different sources.

* Reprinted from *Bell Laboratories Record*, XVIII (May, 1940), p. 260.

** Bell Telephone Laboratories, New York, N. Y.



FIG. 1. Recording amplifiers, low-level reproducing amplifiers, and equipment for compressing and expanding the volume range.

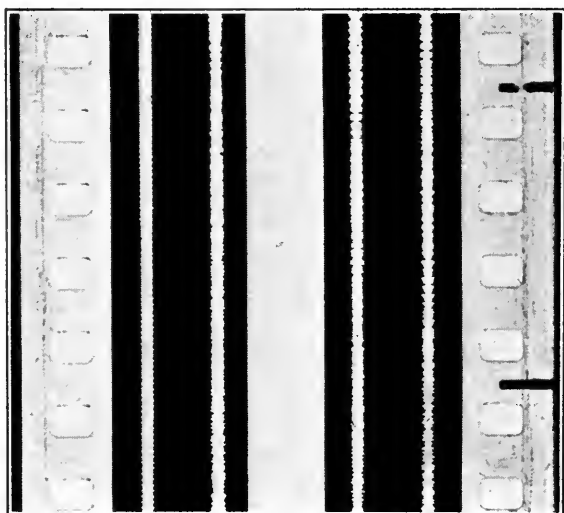

FIG. 2. Enlarged photograph of the positive film used in the final reproduction.

These limitations have long been recognized by the Laboratories, and some years ago an improved sound reproducing system was developed. The result of this work was the stereophonic system demonstrated in Washington and Philadelphia in 1933. Besides reproducing practically the complete frequency range of the orchestra and an enhanced volume range, this system went further in interposing frequency and volume control between the pick-up microphones and the loud speakers to permit the conductor to secure effects unobtainable from the orchestra alone. The music was picked up by three microphones spaced across the front of the stage, and the output from each microphone was carried through its own channel and control equipment to one of three loud speakers spaced across the stage of the auditorium where the reproduction took place.

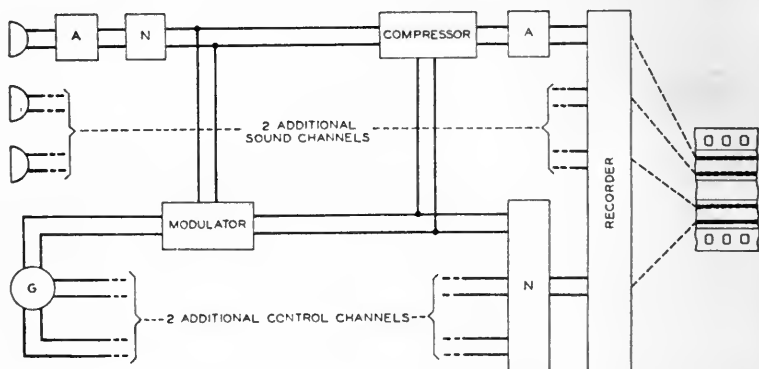
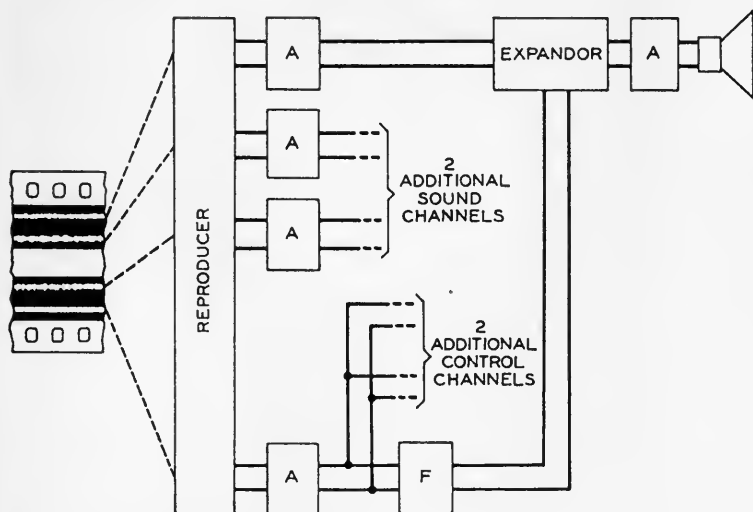

FIG. 3. Block schematic

In the demonstration seven years ago, the music was reproduced at the same time at which it was being played but at a distance from the orchestra. On April 9th of this year a new stereophonic system was demonstrated in New York City, into which another set of steps has been introduced. The music is recorded on film, and is then available for reproduction from the film at any time. Four soundtracks are placed on a single film; one is used for each of the three program channels, and the fourth serves for a control signal. A section of the film is shown in Fig. 2.

This recording on film might seem a simple thing to do. With music and sound so universally recorded on film for sound pictures, there would seem little difficulty to those not technically familiar

with sound-picture systems in recording and reproducing a three-channel stereophonic program. The facts are, however, that ordinary recording and reproduction places no such demands on the equipment as does the stereophonic system. Sound-picture systems transmit a frequency range of less than 8000 cycles, while the stereophonic system employs a band nearly twice as wide. The entire recording and reproducing system had to be designed for this greater range. In addition much greater precautions had to be taken to reduce noise and distortion. An extremely quiet system is required so that



of the stereophonic system.

music at very low volumes, much lower than used in sound-picture systems, is not marred by the noise, and this is made more difficult because of the wider frequency range, which gives a wider band for the entrance of noise. In addition, there is the matter of increased volume range. The maximum volume range that can be placed on a film is less than 50 db, while the stereophonic system, with the 10-db increase and decrease provided by the enhancement control, requires a range of 100 db. At the very outset, therefore, the recording of music for stereophonic reproduction seems faced with an insuperable obstacle.

The seemingly impossible task of recording a program having a volume range of 100 db on a film that will receive only a 50-db range

was accomplished by use of compression and expansion devices performing functions similar to those used on certain transoceanic radio channels. The music as it is picked up by the microphones is passed through a compressor, one being provided for each channel. These allow the music currents to pass to the recording equipment



FIG. 4. The enhancement control unit of the stereophonic system provides both volume and frequency control at the discretion of the conductor.

in their normal volume range if below about 45 db; higher volumes are reduced by the compressor so that the limit of the film recording is not overstepped. At the same time a record is made on another track on the film of just the time and extent of these reductions. At the reproducing end the music currents generated in photoelectric cells from a light-beam passing through the film are carried through an expander before reaching the loud speaker. The action of the

expandor is controlled by a signal obtained from the additional light-track. At any point where the original program was reduced in volume by the compressor, this signal will cause the expandor to increase the volume by just the right amount. In this way the full 100-db range in volume is reproduced by the loud speakers without exceeding the 50-db range that is available on the film.

The main elements of the system are indicated on the block diagram shown as Fig. 3. To control the compressor at the recording end, a small amount of the program current is taken from the circuit just ahead of the compressor and is rectified. This rectified current

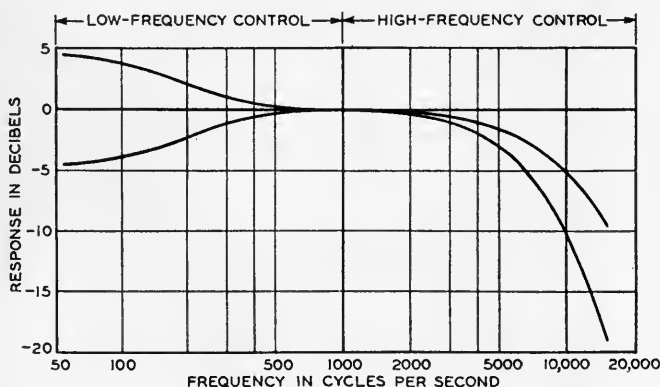

FIG. 5. Frequency characteristics of the stereophonic system obtainable by manipulating the six keys that are located on the top of the enhancement control unit.

modulates a single-frequency current, which then controls the compressor and also forms the signal placed on the fourth track on the film. Since there are three channels, and the amount and time of compression will vary from one to another, three control signals must be recorded on the film, one for each of the three channels. These are all recorded on the same track on the film by allowing the three rectified currents to vary independently the strength of three alternating currents of different frequencies. These modulated currents control their respective compressors and are then combined and recorded as the fourth track.

After the film has been made, if the music is then to be enhanced, it is reproduced while the original conductor listens and manipulates the enhancement controls to modify the frequency and volume

ranges of the three channels and thus to secure an effect that more nearly suits his interpretation. The enhancement control unit is shown in Fig. 4. At the top are six keys used to control the frequency composition—there is one for each channel for adjusting the high frequencies, and one for each channel for the low frequencies. Each key has three positions and gives the control indicated by Fig. 5. The three handles on the front of the control unit are for adjusting the volumes of the three channels. As the handles are moved up from the normal position, the volume is increased, and as they are moved down, the volume is decreased. As the conductor listens to the reproduction of the original recording, he manipulates these controls, and another film record is made of the enhanced program.

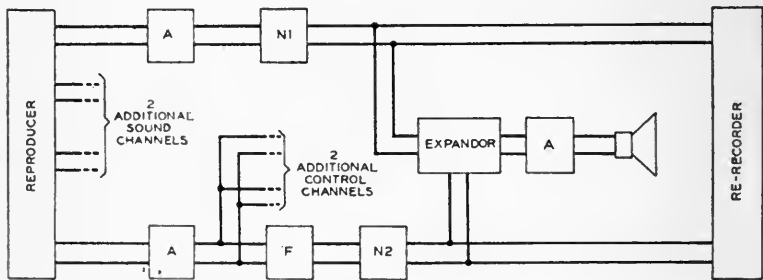

FIG. 6. Block schematic of circuit used for enhancing and re-recording.

A block schematic for this phase of the operation is shown in Fig. 6, which shows only one channel, however. The changes in frequency characteristics brought about by the enhancement control are secured by the insertion or removal of electrical filters, marked *N1* in Fig. 6, in the circuit for each channel. The volume control modifies the current of the auxiliary channel, which is used to control the action of the expandors. Both networks, *N1* and *N2*, are inserted in the circuit ahead of the point where the monitoring circuit is taken off, and thus modify the program as heard by the conductor as well as the currents used for making the new film. On the new film, the three program sound-tracks are the same as on the original film except for the frequency modifications brought about by the filters. The control track, however, has been modified by the manipulation of the enhancement control so as to cause greater or less expansion when

result of this process thus represents the enhanced program, and is the one used.

Besides the compressors, expandors, and filters required for this new system there has been a considerable amount of incidental development of the associated parts. There had to be provided, for example, a carefully designed source for the three signal frequencies used to control the expandors, and narrow band-pass filters to separate the three frequencies at the reproducer so that each would control its own expander. Other developments were required to secure accurate timing. The signals must cause the expandors to act at exactly the same point on the film that the compressors had acted during the original recording. In addition, practically every piece of equipment had to be studied and partly re-designed to reduce noise and distortion that in other circumstances would be unobjectionable.

THE EFFECTS OF ULTRAVIOLET LIGHT ON VARIABLE-DENSITY RECORDING AND PRINTING*

J. G. FRAYNE AND V. PAGLIARULO**

Summary.—The effect of using ultraviolet filters on the gamma of negative and positive development is discussed. The effect of ultraviolet light on image quality is discussed and a mathematical analysis is given explaining the existence of spurious side images found in white-light recording on clear-base variable-density negatives. Low-end frequency rise, attributed to existence of these side images, is eliminated by recording with ultraviolet. Reduction in wave-shape distortion as well as improvement in high-frequency response is attributed more to use of ultraviolet in printing than in recording. Practically no gain in signal-to-noise ratio is found by using ultraviolet in either recording or printing.

The use of the shorter-wavelength bands in the visible spectrum has long been recognized in the science of photography as an aid in obtaining improved resolution and increased sharpness of image in photographic emulsions. The development of ultraviolet filters in recent years has made it possible to extend investigation of film characteristics into the longer ultraviolet region, the results indicating further improvement over that previously established for the blue-violet region. The increase in image sharpness produced by use of ultraviolet light has proved to be important in variable-width sound recording where a sharp demarcation between black-and-white regions is essential for faithful rendition of the impressed wave-form. The importance of ultraviolet in this field is now well established and is used in the printing as well as in the recording operation.¹

In the variable-density method of recording the same necessity for sharp edge definition does not ordinarily arise but it has been found that the use of a limited band exclusively in the ultraviolet or extending a short distance into the visible region may prove effective in improving the quality of sound recorded in this manner. In practice these limited-wavelength bands are obtained by inserting suitable

* Presented at the 1940 Spring Meeting at Atlantic City, N. J.; received April 26, 1940.

** Electrical Research Products, Inc., Hollywood, Calif.

optical filters in the light path of the recorder or printer tungsten lamp or mercury arc being employed as light-source.

The transmission characteristics of several commercially available filters is shown in Fig. 1, which also shows for reference the film sensitivity and absorption characteristics of the Eastman Kodak 1359 emulsion. The narrowest of these filters passes a band starting from 4000 Å down to approximately 3000 Å, while the broadest transmits a band from approximately 4200 to about the same short-wavelength

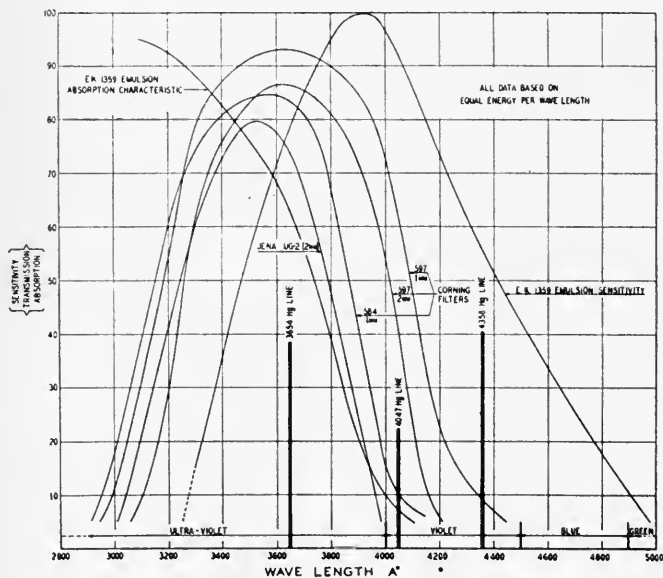

FIG. 1. Sensitivity and absorption curves of sound negative emulsion and transmission characteristics of filters. Based on equal energy per wavelength.

cut-off. It will be noted that the transmission of the narrowest filter corresponds quite closely to the spectral absorption characteristic of the emulsion and should therefore prove most effective in reducing light-scattering within the emulsion. All the curves in Fig. 1 are based on transmission of light with equal distribution of energy per wavelength. It is interesting to note the effect of these filters on the transmission of mercury arc radiation from a lamp such as the G.E. H3X which is currently being employed in exposing fine-grain variable-density sound negatives. The 3654 Å line comes within the

range of optimum transmission of all the filters analyzed, while the 4358 line, which is slightly more intense than the former, is completely filtered out. The Jena *UG-2* filter completely excludes the 4047 line, while it is transmitted in part by any of the other filters shown in this chart. The combination of the mercury arc with the *UG-2* filter should provide, in effect, monochromatic recording.

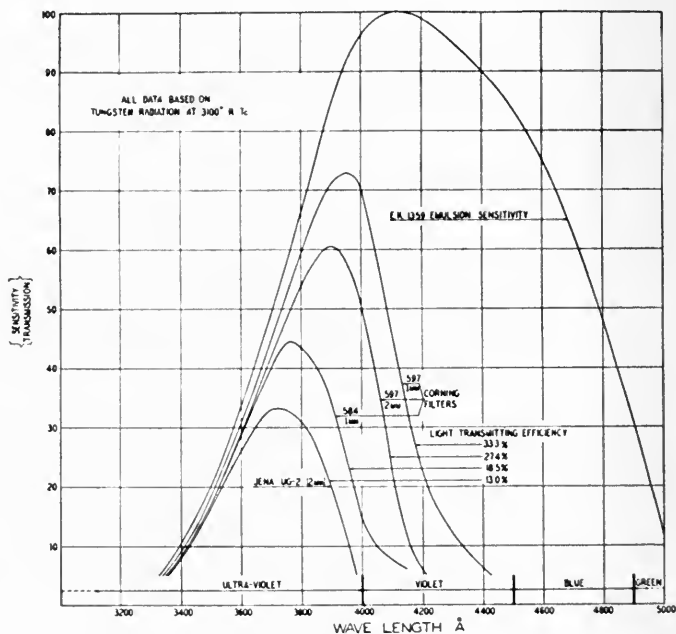

FIG. 2. Sensitivity of sound negative emulsion and transmission characteristics of filters. Based on tungsten light at 3000°K.

Since filters are being employed to a certain extent with tungsten lamp sources, it is of interest to note the transmission characteristics of the same filters for tungsten radiation and at the same time permit some evaluation of the efficiency of these various filters when thus employed. The curves in Fig. 2 show the film sensitivity of 1359 emulsion to a tungsten source operating at a color temperature of 3100°K. The ordinates of the curves designated by the filter numbers were obtained by multiplying the transmission ordinates of Fig. 1 by the film sensitivity ordinates of the same figure and by the spectral energy distribution ordinates of the tungsten lamp operated

at 3100°K. The ratio of the areas under the various filter curves to the area under the film sensitivity curve represents the optical transmitting efficiency of the various combinations employed. The efficiency of these filters is lowered somewhat in practice by the attenua-

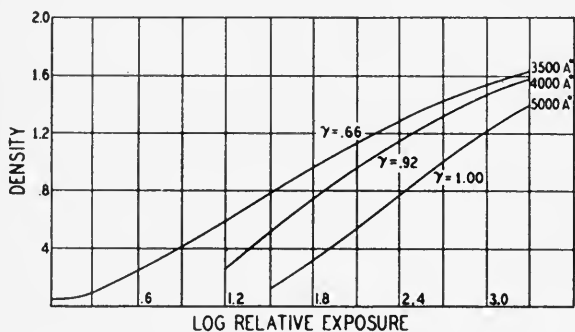

FIG. 3. Variation of gamma with wavelength for E.K. 1359 emulsion.

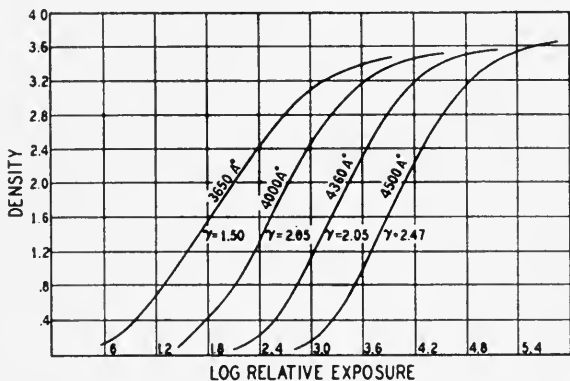

FIG. 4. Variation of gamma with wavelength for E.K. 1301 emulsion.

tion of the shorter-wavelength radiation by the glasses in the optical system of recorder or printer. This situation is, however, being gradually rectified by the introduction of quartz and other glasses having high optical transmitting efficiency in the near ultraviolet.

EFFECT OF ULTRAVIOLET ON GAMMA

Since the gammas of the negative and positive development play an important part in determining the quality of variable-density records, it is important to find what effect the use of short-wavelength light has on these control factors. It has been shown by Ross² that the gamma increases progressively from the shorter toward the longer wavelengths of the spectrum. A typical set of curves showing relation of gamma to wavelength for Eastman Kodak sound recording negative emulsion 1359 is shown in Fig. 3, where the gamma changes

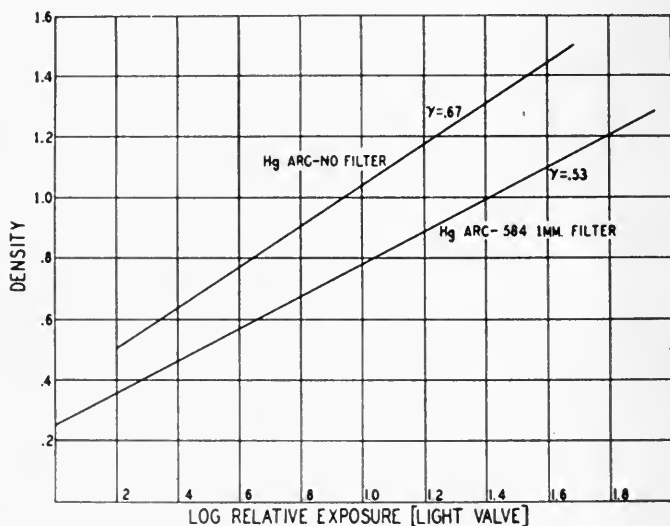

FIG. 5. Effect of ultraviolet filter on sound negative gamma.

from a value of 0.66 for 3500 Å to 1.0 at 5000 Å. A similar set of curves is shown in Fig. 4 for Eastman Kodak standard positive emulsion 1301, which shows a gamma change from 1.50 at 3650 Å to 2.47 at 4500 Å.

The curves in Fig. 5 show the actual change in gamma induced in a sound negative when exposed (a) to unfiltered mercury arc light, and (b) to the same arc plus a Corning 584, 1-mm filter. The value of gamma is reduced from 0.67 to 0.53, or about 20 per cent. The curves in this figure show only the straight-line portions of the negative H&D curve made by exposing the film through a light-valve used as a sensitometer.³ It should be pointed out that the variation

in negative gamma shown here was found for that type of negative development employed when ultraviolet printing is anticipated, and may not hold for the shorter time of development with consequent lower gamma usually employed where white-light printing of the negative is anticipated. In practice the relation between the white-

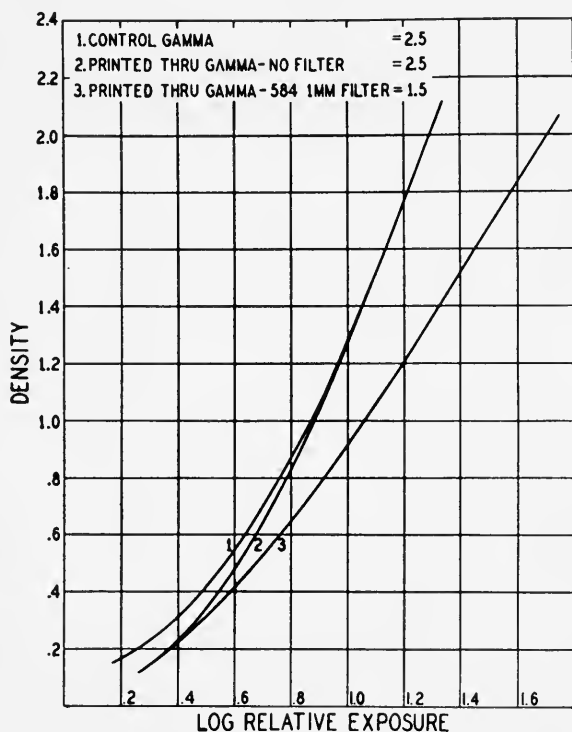

FIG. 6. Effect of ultraviolet filter on sound positive gamma.

light control-gamma and that obtained for the particular filter and time of negative development used must be established.

In Fig. 6 are shown typical results of printing through an ultraviolet filter. In this case the filter employed was a 2-mm 584. Curve 1 shows the standard white-light control H&D curve with a gamma of 2.5. Curve 2 is an H&D curve obtained by printing with unfiltered tungsten light through a negative sensitometric strip onto the positive film. The gamma here again is 2.5. Curve 3 represents the

printed-through H&D curve employing the ultraviolet filter. Here the gamma has a value of 1.5, a reduction of 40 per cent from the unfiltered white-light condition. If this ultraviolet condition is used in printing variable-density negatives, the negative gamma customarily employed for white-light printing must be increased proportionately.

EFFECT OF ULTRAVIOLET ON IMAGE QUALITY

The application of ultraviolet light to variable-density has proved very effective in reducing image spread within the emulsion and in

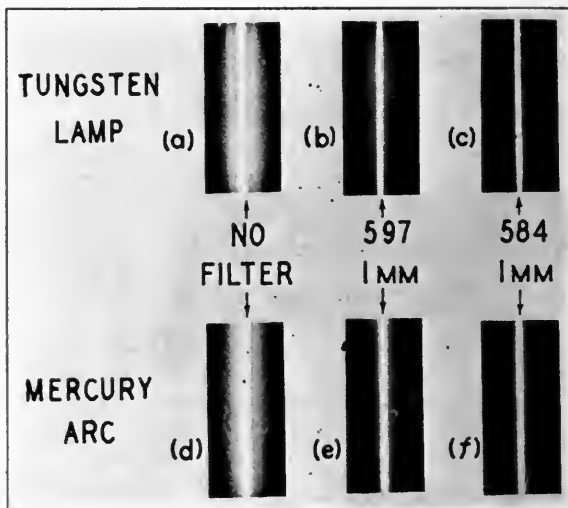

FIG. 7. Photographs of image structure for various conditions of exposure.

elimination of halation found in clear-base films. This halation is caused by total reflection of scattered light reaching the back film-base-air surface at angles beyond the critical angle. The halation present in unfiltered tungsten light recording has previously been shown to produce two distinct images occurring on either side of the central image.⁴ The photograph in Fig. 7(a) shows the existence of side images and image spread in a standard clear-base sound negative emulsion exposed to unfiltered tungsten light. The intensity of the side images is considerably reduced when the exposure is made through a Corning 2-mm 597 filter as in Fig. 7(b). In Fig. 7(c), made through a 1-mm 584 filter, the side images are no longer present, and a con-

siderable reduction of image spread is also noted. Fig. 7(d), (e), and (f) shows similar results where an *H3X* mercury arc is substituted as a light-source. It will be noted that the unfiltered image is somewhat superior to that obtained with unfiltered tungsten light. This is undoubtedly due to the absence of any radiation in the region between the 4358 Å line and the long-wavelength limit of film sensitivity where the film emulsion offers little absorption to the incident light-beam. Tests made in both recording and printing show that when a tungsten lamp or a mercury arc is filtered through a 1-mm or 2-mm 584 filter, the results are identical.

The photographs in Fig. 8 show that the side images caused by halation may be eliminated in other ways than by resorting to ultraviolet in the recording process. Fig. 8 shows the effect of using a



FIG. 8. Photographs of image structure: (left) gray base, (right) yellow die in emulsion.

gray-backed sound emulsion exposed by unfiltered tungsten light, and the effect of using a yellow-dyed type of emulsion, the exposure in this case being made with unfiltered mercury arc. It will be noted that the image spread is still predominant with the gray-backed emulsion, but that with the use of the yellow dye this effect is eliminated as well as the effects traceable to halation.

A mathematical analysis on the effect of the existence of these side images on a recording frequency characteristic is given in *Appendix A*. It is first established that for a film-base thickness of 5.5 mils and index of refraction of 1.503, the distance from the centerline of the principal image to inside edge of either side image is 9.8 mils, which agrees closely with a measured value of 9.35 mils. Now the existence of these side images causes three distinct exposures at any point of the emulsion as it crosses the three images. Since these exposures will add in various phases the amplitude of modulation of the film will vary with frequency, although the amplitude of modula-

tion of the impressed signal is kept constant over the frequency range covered. It is shown that for normal motion picture positive film the amplitude decreases gradually from zero frequency to a minimum at about 900 cycles, rising again to a maximum at 1800, with successive maximum and minimum every added 900 cycles. This abnormal frequency response, which is chiefly observed in practice as a rising low-end characteristic, has been recognized for some time but as far as is known, no explanation was available until the present analysis had been made. Typical frequency response characteristics between 100 and 2000 cycles are shown in Fig. 9, Curve 1 being exposed and

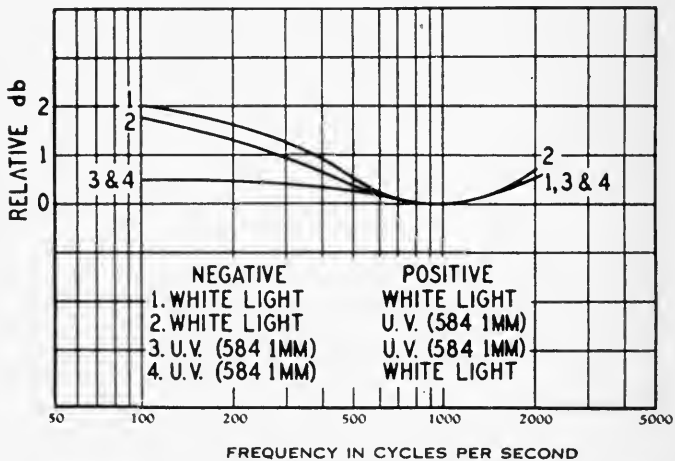

FIG. 9. Low-end frequency characteristics for various recording and printing conditions.

printed with unfiltered tungsten light; whereas Curve 2 is exposed with unfiltered tungsten light but printed with ultraviolet light as transmitted through a Corning 584 1-mm filter. It will be noted that the use of ultraviolet in printing brings about only a small reduction in this abnormal low-end frequency rise, which indicates that the effect is mainly recorded in the negative. Curves 3 and 4, which are superimposed, were both recorded with a Corning 584 1-mm filter, ultraviolet printing being employed for 3 and white-light printing being employed for 4. In this case the low-end rise amounts to only $1/2$ db at 100 cycles.

EFFECT OF ULTRAVIOLET ON WAVE-SHAPE DISTORTION

The spreading of the image within the emulsion, illustrated in Fig. 7, by the use of unfiltered tungsten light undoubtedly contributes to wave-shape distortion of the recorded sound. To test this, intermodulation measurements⁴ were made in which white-light negatives, printed with both white and ultraviolet light, and ultraviolet negatives, also printed with both white and ultraviolet light, were analyzed for minimum intermodulation distortion. The overall gamma in

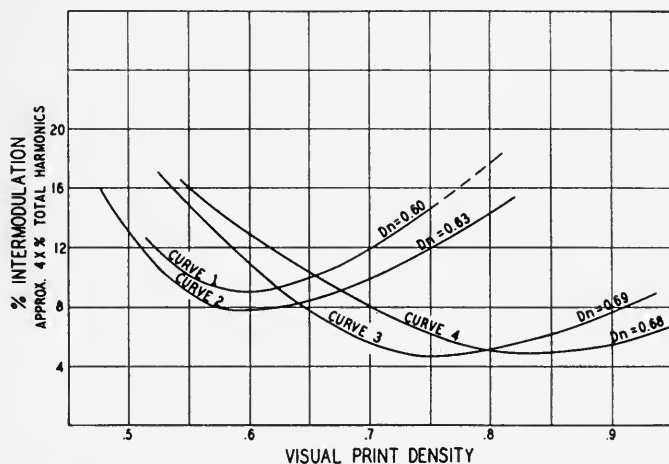

FIG. 10. Intermodulation as function of print density.

- Curve 1 White-Light Negative, White-Light Print
- Curve 2 Ultraviolet Negative, White-Light Print
- Curve 3 White-Light Negative, Ultraviolet Print
- Curve 4 Ultraviolet Negative, Ultraviolet Print

every case was held close to the desired value of unity. Results are shown in Fig. 10. Curve 1 represents the condition for unfiltered tungsten light exposure of the negative and positive. A minimum intermodulation value of about 9 per cent was obtained at a print density of 0.6. Curve 2 shows results obtained when a negative exposed through a 1-mm 584 filter is printed with unfiltered tungsten light. A reduction of about 1½ per cent in minimum intermodulation value is obtained by this procedure. Curve 3 shows a white-light negative printed through a 1-mm 584 filter. A marked drop in distortion to a minimum of about 4½ per cent at a print density of 0.75 is now obtained. Curve 4 shows the results of ultraviolet printing

of an ultraviolet exposed negative. No further reduction in minimum distortion is obtained and the optimum print density is now obtained at a value of about 0.85. These curves would indicate that from the standpoint of reducing wave-shape distortion, ultraviolet printing plays a more important part than ultraviolet recording.

An explanation of the results shown in Fig. 10 may be somewhat as follows. In Curve 1 the optimum print density of 0.6 is lower than would be required by classical sensitometry, and indicates that at this point a balance is reached between distortion in the dark portion of the wave in which image spread appears to be most serious and curvature in the light portion due to operation into the toe of the H&D curve. The relatively high residual distortion points to severe curvature at both ends of the film transmission scale. The use of ultraviolet in Curve 2 results only in a slight reduction of the minimum distortion and a negligible shift in optimum print density. This is probably due in part to the fact that the effect of the ultraviolet on the negative is limited by the fact that development at a low gamma is confined almost exclusively to the surface and many of the grains exposed by the scattered light within the emulsion are not developed. Consequently, in Curve 2 the white-light printing technic is the dominant effect. In Curve 3, where a white-light negative is printed with ultraviolet, a pronounced reduction of distortion as well as a marked shift to a higher optimum print density are noted. Here the ultraviolet light eliminates the excessive image spread in the high-density region, and since the toe curvature is now the predominant distortion, the optimum density is shifted to the straight-line portion of the positive H&D curve in accordance with sensitometric predictions. In Curve 4 the use of ultraviolet in both negative and positive eliminates all image spread in both processes. This condition should therefore produce results most in harmony with the classical sensitometric theory.

EFFECT OF ULTRAVIOLET ON HIGH-FREQUENCY RESPONSE

The effect of ultraviolet light on high-frequency response may be considered from two different approaches: first, where the ultraviolet light is used in the printing; second, where it is employed in recording. The results of printing with the various bands of ultraviolet light are shown in Fig. 11, where the results are compared to a frequency film recorded and printed with white light. Curve 1 in this figure shows the net improvement obtained when the white-

light negative is printed through a 584 ultraviolet filter. For this particular printing condition a net gain of about 3 db is obtained at 9000 cycles. Curve 2 in the same figure shows the net improvement when the print is made through the broader Corning 597 type filter. The net gain here amounts to about 2 db at 9000 cycles. It should be pointed out here that the apparent improvement brought about in high-frequency response by the addition of ultraviolet filters to printers depends to some extent on the mechanical condition of the

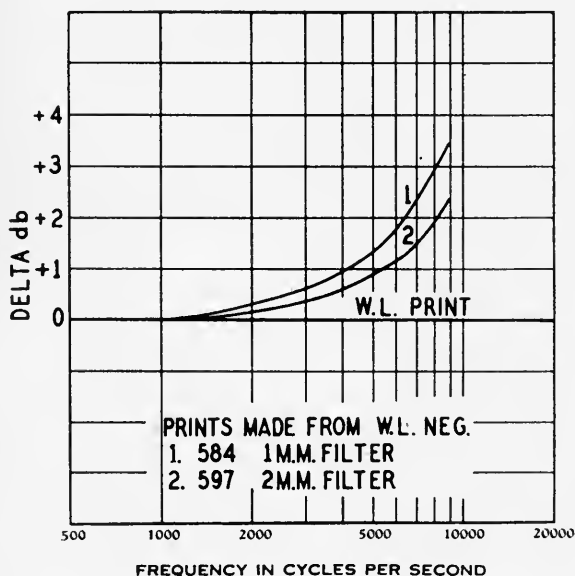

FIG. 11. Net improvement in high-frequency response of ultraviolet prints over white-light prints.

printers. It has been found, for example, that a printer which may show serious high-frequency printing losses with white light, may show a much greater net improvement when ultraviolet is employed than a printer which appears to provide better definition under white-light printing conditions. The results shown here represent the performance to be expected from a printer in somewhat better-than-average mechanical condition.

Fig. 12 shows the net improvements in high-frequency response to be expected from the use of ultraviolet light in recording. The

peculiar shape of this curve between 1000 and 4000 cycles is due to the fact that in this region the use of ultraviolet in the negative appears to introduce a loss in amplitude which can be traced to the elimination of the spurious amplitudes caused by the existence of side images in white-light recording. The net gain, which is an average for Corning 597 and Corning 584 filters, amounts to about $1\frac{1}{2}$ db at 9000 cycles. This indicates that the effect of using ultraviolet light in the negative results in a smaller improvement at the higher frequencies than is realized in printing. This indicates again

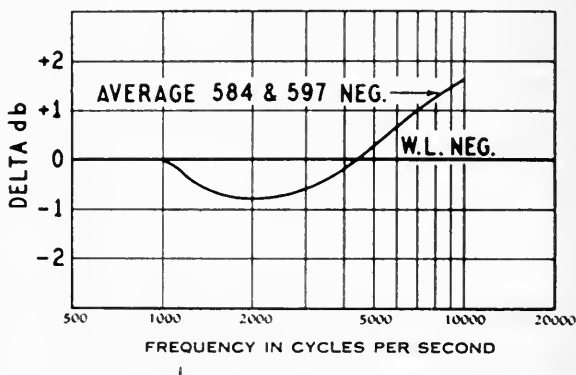

FIG. 12. Net improvement in high-frequency response of prints of ultraviolet negative over that of white-light negative.

that the low negative gamma development of variable-density track results in less blurring or image spread than is encountered in the printing process where longer development and higher densities bring about a greater distortion of the image with resultant loss in high-frequency definition. The frequency negatives used in arriving at the curves in Fig. 12 were all made with a lens system which was corrected for chromatic aberration in the near ultraviolet and the violet region of the spectrum. Without the correction in the ultraviolet region, the measurements showing improved high-frequency definition with ultraviolet light would probably not have been obtained with tungsten light as the exposing source, since the beneficial effects of the short-wavelength light would have been offset by chromatic aberration in the lenses.

COMPARISON OF ULTRAVIOLET SOURCES

The relative inefficiency of a tungsten light-source as a source of ultraviolet light has led to considerable activity in the development and use of other sources rich in ultraviolet. The G.E. *H3X* lamp previously mentioned has already gained wide use as a printing-light source. Although this type of lamp requires a special power supply, either a motor-generator or a stabilized rectifier source, this presents no great problem when the arc is used for film laboratory service or on fixed sound recording channels. The power supply on truck and portable channels presents a more difficult problem and has retarded the use of the arc for this kind of service. The relative value, from a photographic standpoint, of these two sources of ultraviolet has been examined and the data in the table below show the relative performance of these sources when used in printers with and without filters.

Comparison of Printing Light Sources

	Incandescent Lamp		Mercury Arc	
	No Filter (1)	No. 584 (2)	No Filter (3)	No. 584 (4)
1000	0	0	0	0
3000	1.3	1.3	1.6	1.2
5000	1.7	2.5	2.2	2.4
7000	2.5	4.8	3.8	4.2
9000	6.0	9.2	8.2	9.2

Column 1 shows the response obtained for an incandescent lamp without filter. This should be compared with Column 3 which shows the response for the same negative printed with the mercury arc source without filter. The unfiltered arc appears to be superior as a printing-light source. Columns 2 and 4 show the results obtained from interposing the same filter in incandescent lamp and mercury arc sources, respectively. The performance here appears to be almost identical, so that as far as image definition is concerned it appears to be immaterial from what source the ultraviolet band is obtained. In recording the negative, the tungsten lamp appears to be equally effective as the mercury arc source when both are suitably filtered, provided the lens system is properly corrected over the ultraviolet region. The mercury arc shows some advantage for a lens not corrected in this region since its radiation when properly filtered is limited to essentially a monochromatic beam.

EFFECT ON SIGNAL-TO-NOISE RATIO

Reference to the *Appendix* at the end of this paper shows that because of the functional relationship existing between the exposures when white light and ultraviolet light, respectively, are employed, the amplitude of a recorded 1000-cycle frequency should be lower by about 0.8 db when white light is employed than when ultraviolet filtering is used in the recording process. Since 1000 cycles are generally used in making signal-to-noise measurements, a net gain of about 0.8 db should be found in the output of a print made from an ultraviolet negative over that found in a print made from a white-light negative, irrespective of the nature of the printing light. An actual net gain in signal-to-noise ratio of about 1 db has been repeatedly found in comparing prints from ultraviolet and white-light negatives. This indicates that the small gain found in signal-to-noise measurements is to be attributed to the increased signal output caused by using ultraviolet in recording rather than to any reduction in ground noise resulting from the use of ultraviolet in exposing negative or print.

CONCLUSIONS

The results of using ultraviolet light in variable-density recording and printing may be summarized as follows:

- (1) The use of an effective ultraviolet filter reduces both negative and positive gammas from the normal white-light control gamma, necessitating changes in developing times to offset these reductions.
- (2) Side images caused by halation are eliminated. This makes possible a flat low-end frequency response.
- (3) Image scattering or spread is practically eliminated, thus reducing wave-shape distortion and improving high-frequency response.
- (4) The use of ultraviolet is more important in printing than in recording.
- (5) The improvement in signal-to-noise ratio is negligible.

REFERENCES

- ¹ DIMMICK, G. L.: "Improved Resolution in Sound Recording and Printing by the Use of Ultraviolet Light," *J. Soc. Mot. Pict. Eng.*, **XXVII** (Aug., 1936), p. 168.
- ² ROSS, F. E.: "The Physics of the Developed Photographic Image," p. 80.
- ³ MACKENZIE, D.: "Straight-Line and Toe Records with the Light Valve," *J. Soc. Mot. Pict. Eng.*, **XVII** (Aug., 1931), p. 172.
- ⁴ FRAYNE, J. G., AND SCOVILLE, R. R.: "Analysis and Measurement of Distortion in Variable-Density Recording," *J. Soc. Mot. Pict. Eng.*, **XXXII** (June, 1939), p. 648.

APPENDIX

In Fig. 13 is shown how light is reflected and refracted in passing from a denser medium into a lighter medium when the phenomenon of total reflection takes place. Rays b , c , and d are scattered at various angles as the incident light reaches the emulsion. For ray b the angle of scattering is less than the critical angle and only a small part of the energy of the ray is reflected back toward the emulsion. For ray d the angle of scattering is the critical angle and none of the energy is reflected back. For ray c the angle of scattering is slightly greater than the critical angle and all the energy is reflected back toward the emulsion.

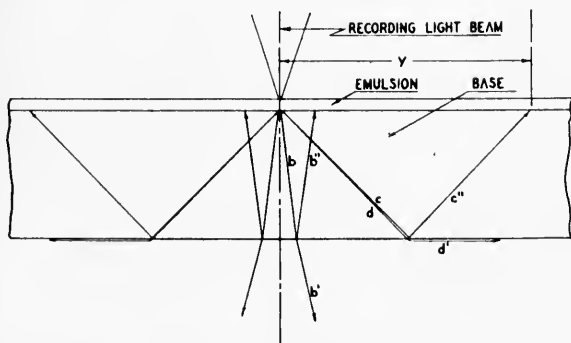

FIG. 13. Illustration of reflection at critical angle of light scattered by the emulsion.

Because the reflected part of ray c , namely, c'' , contains more energy than the reflected part of ray b , it will be able to produce greater exposure of the emulsion, as is shown in Fig. 7(a).

- Let y = distance between the central image and the side image.
 e = thickness of the film base.
 θ = critical angle of scattered light.
 u = index of refraction of the base material.

From the figure

$$y = 2e \tan \theta = \frac{2e \sin \theta}{\sqrt{1 - \sin^2 \theta}} \quad (1)$$

This is permissible because the angle of scattering of ray c is only slightly greater than the critical angle and to a very close approximation can be made equal to it.

The condition for total reflection is:

$$\sin \theta = \frac{1}{u} \quad (2)$$

and by substitution:

$$y = \frac{2e}{\sqrt{u^2 - 1}} \quad (3)$$

In the usual films $a = 5.5$ mils, $u = 1.503$. Using these values, then $y = 9.8$ mils. By actual measurement the average value of y was found to be 9.35 mils.

To determine what is the effect of the side images in film recording, it may be assumed that any point on the film while in motion in the recorder receives three discrete exposures as it crosses the side images and the central image, and that these exposures are additive.

Let a = width of each image in the direction of motion of the film.

v = velocity of the point on the film.

I = light intensity at side image.

n = ratio of intensities between central image and side image.

y = distance between centers of side image and central image.

t = time when the point on the film crosses the center of the central image.

$t - \frac{y}{v}$ = time when the point crosses the center of the first side image.

$t + \frac{y}{v}$ = time when the point crosses the center of the second side image.

w = circular frequency.

Assuming 100 per cent modulation of a sinusoidal impressed signal of constant amplitude, the individual exposures will be:

$$e_1 = I \frac{a}{v} \left[1 + \sin w \left(t - \frac{y}{v} \right) \right] = \text{Exposure received by the point in crossing the first side image}$$

$$e_2 = nI \frac{a}{v} \left[1 + \sin wt \right] = \text{Exposure received by the point in crossing the central image}$$

$$e_3 = I \frac{a}{v} \left[1 + \sin w \left(t + \frac{y}{v} \right) \right] = \text{Exposure received by the point in crossing the second side image}$$

After expanding the equations for e_1 and e_3 and adding these to the equation for e_2 the total exposure is obtained.

$$E = e_1 + e_2 + e_3 = \frac{nIa}{v} \left[\left(1 + \frac{2}{n} \right) + \left(1 + \frac{2}{n} \cos \frac{wy}{v} \right) \sin wt \right]$$

It is noted that while in the individual exposures the amplitude of the signal was constant, the addition of these exposures produces a

total exposure in which the amplitude of the signal is a function of frequency, which is contained in w . The amplitude will have several maxima and minima. The first minimum will occur when:

$$\frac{wy}{v} = \frac{2\pi fy}{v} = \pi$$

or

$$f = \frac{v}{2y}$$

In practice v is 18,000 mils per second and y was found above to be close to 10 mils, so that when these values are substituted above, it is found that the first minimum is obtained at a frequency of about 900 cps, which is verified in all the experiments so far performed.

Experiments indicate that with white-light recording and printing, the difference between maximum signal output and minimum signal output from a print is of the order of 2 db (see Fig. 9). Since the amplitude ratio corresponding to this difference must be equal to the ratio of the amplitudes, we have:

$$1.26 = \frac{1 + \frac{2}{n}}{1 - \frac{2}{n}}$$

or n for this case has a value of about 17.4. For the case of ultraviolet light recording and printing, the difference between maximum and minimum output is of the order of 0.5 db from which, applying the same criterion, there results a value of n equal to 68.7.

SILENT VARIABLE-SPEED TREADMILL*

J. E. ROBBINS**

Summary.—Treadmills are a definite necessity to the making of motion pictures for the purpose of obtaining intimate scenes of animated objects or persons working before moving backgrounds. The evolution of this type of equipment dates back to the very beginning of the industry. Due to the fact that noise was of no consequence, these earlier machines were simply and crudely constructed. The type generally used employed the ordinary conveyor-chain principle, utilizing web belts running over series of rollers. Other developments include the revolving disk type, not entirely desirable due to the variation of surface speed in relation to the distance from the center of the circle; the gravity unit motivated by the persons or animals walking or running on them, etc., etc. Inasmuch as these were generally operated in front of sky backings or moving panoramas, speed ranges obtainable by gear boxes or belt pulley or chain sprocket changes were adequate. With the advent of sound and a more general use of the transparency or process background the need of smoother, more flexible, silent mills was recognized. The problem was carefully considered by the engineering department of Paramount Pictures, Inc., and the unit recently developed by them embodies all the previously mentioned requisites and to date has operated satisfactorily under the most trying conditions.

Construction details, speeds, degrees of silence, and other factors are covered in the paper.

The treadmill, a vital necessity, has been used by the motion picture industry since its inception. Early types, generally used in front of sky backings or moving panoramas, were simply and crudely constructed, employing the principles of ordinary chain belt conveyors. These machines were jerky, noisy, restricted as to speed range, etc. There were, in addition to this type, the revolving disks, not too practicable due to the variation of surface speed as the distance increased from the center of the circle; the gravity type; the horse power units, still employed for fast running scenes shot in sync; the slatted roller design; etc. With the advent of sound all scenes requiring the use of mills were shot synchronously. This, and the fact that many important situations obtainable with more modern

* Presented at the 1940 Spring Meeting at Atlantic City, N. J.; received April 6, 1940.

** Paramount Pictures, Inc., Hollywood, Calif.

transparency or process developments were being lost due to inadequate facilities, hastened the development of a machine such as the one herein described.

This treadmill weighs 7000 pounds, is 16 feet, 6 inches long, 9 feet, 4 inches wide, and 34 inches to the top of the floor (Fig. 1). Each of these mentioned dimensions was carefully considered, in development, in an effort to create a unit that would offer the greatest possible belt surface and at the same time be sufficiently compact to afford efficient operation in close quarters, ease of handling, possible

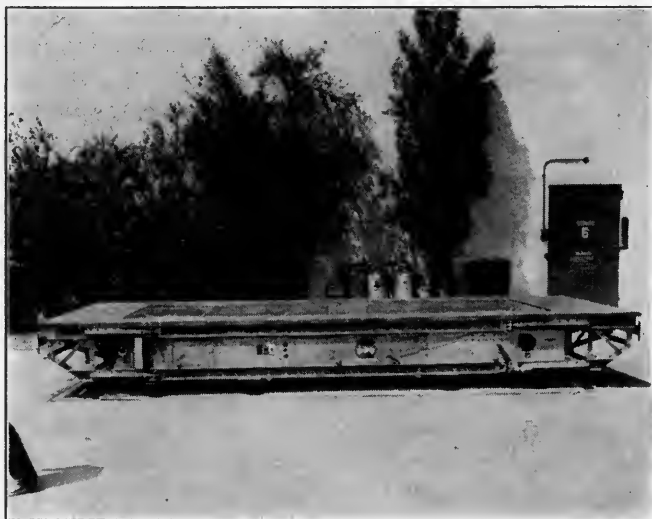

FIG. 1. Silent variable-speed treadmill.

off-the-lot transportation, and uniform parallel and transparency or process screen heights. Detachable pieces are provided for getting on or off, in action, which add 6 feet to the overall length of the machine. The belt, especially designed, is 38 feet, 4 inches long, 84 inches wide, 6-ply canvas inside, and rubber topped. This belt runs over canvas-lagged drums 24 inches in diameter, ball-bearing mounted on shear rubber at the end of the machine. Adjustment screws are provided on the driven end for tightening and to compensate for floor and other irregularities. They are also utilized to relieve the tension when not in use. The drums support no weight, inasmuch as the belt glides over a $\frac{3}{4}$ -inch fluted maple floor. Incidentally, the elimi-

nation of all noises created by the floor, belt whistle and squeal, squeaks, drumming, effect, *etc.*, presented one of the most difficult problems. This was solved, however, by gluing the entire piece as one unit, impregnating the wood with a patented preservative containing a large percentage of wax, providing longitudinal grooves $\frac{3}{8}$ inch wide and $\frac{1}{4}$ inch deep, full length, and mounting the wooden section on $\frac{1}{2}$ -inch felt strips securely screwed to the cross frame, with all screw holes doweled and polished. French talc is distributed under air pressure over the floor at the entering edge by means of perforated pipe. The frame is constructed of duralumin throughout. Bolts were used in lieu of rivets, in fabrication, to provide for future tightening where, due to rivet failure, squeaks might develop.

Motive power is supplied by a 10-hp, d-c, compound-wound motor mounted on shear rubber in an independent sound-proof compartment. From this point transmission is effected at a three to one ratio through multiple *V* belts to a twelve to one, electrically operated, speed-changer of the variable-pitch-diameter type. This is a commercial unit. However, it was necessary to replace the leather and wooden stiffener driving belt with an especially designed fabric and rubber member with steel crosspieces vulcanized into the core. This eliminated all chattering, drumming, and pounding. The driven shaft of the changer is directly connected through universal joints to one 6 to 1 herringbone reducer on each side. The reducers and the variable-pitch-diameter speed-changer are also shear rubber mounted. Sprockets on each side of the driving drum are connected through double roller chains to the 6 to 1 reducers at a ratio of 2 to 1. The total overall reduction through the drive described is 216 to 1. The combination of direct-current motor and speed-changer afforded a speed range of the belt from zero to 720 feet per minute, in either direction, operable at any distance by remote control. The entire power and transmission unit is, as previously explained, shear rubber mounted inside the mill, with the exception of the driving and driven drums. Each unit, in its separate compartment, is carefully treated with slabs of acoustical boards $1\frac{1}{2}$ inches thick. In addition to this, hair-felt is packed into all other open spaces. Eight swivel casters are mounted on the frame for portability and a like number of screw-jacks provided for leveling and solid footing.

This combination has made possible scenes otherwise unobtainable. Slow walks, marching soldiers, running horses, motorcycle, bicycle, and other such animated shots are now obtained with little, if any,

trouble due to noise from the treadmill. The extent to which these measures have been successful in reducing overall noise to acceptable values for sound motion picture work may be seen in the curves of Fig. 2 which are the results of measurements made with a General Radio noise meter using the 70-db weighting scale. The microphone of the noise meter was located about five feet above the center of the treadmill which approximates the most frequently used position of the sound recording microphone for motion picture work.

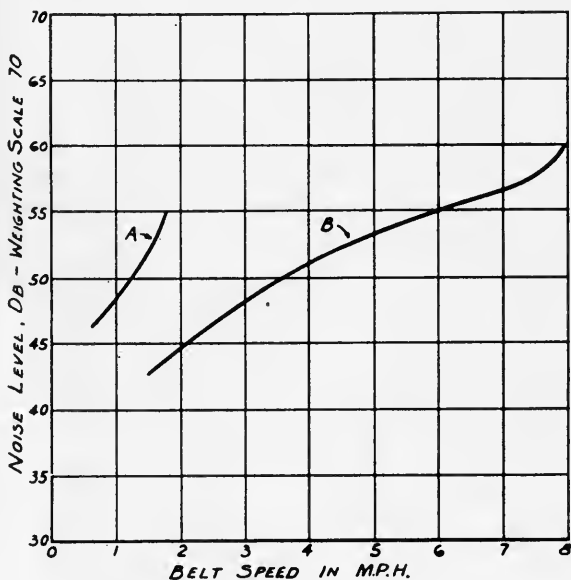

FIG. 2. Noise measurements of treadmill.

Curves A and B indicate the noise produced by the treadmill with the variable-speed transmission adjusted, respectively, for maximum and for minimum overall gear reduction between motor and treadmill belt. For this reason Curve A covers a comparatively narrow range of belt speed from about $\frac{1}{2}$ mile per hour to about $1\frac{3}{4}$ miles per hour; while Curve B, having approximately the same range of motor speed, covers belt speeds from $1\frac{1}{2}$ to nearly 8 miles per hour. From these two curves, it is apparent that, while belt noise is always a factor, it is subordinate to the noise arising from the motor and associated drive elements ahead of the variable-speed transmission until belt

speeds above six miles per hour are reached. With the variable-speed transmission adjusted for minimum gear-reduction ratio, approximately three times the belt velocity may be had for any given amount of noise; or, conversely (for the only region where the curves yield such information), a given velocity may be had with approximately 12 db less noise.

It is also apparent from these curves that proper selection of the variable-speed transmission ratio makes it possible to secure belt speeds sufficient for all average walking shots without introducing noise more than 10 or 12 db above that of a very quiet sound recording stage. This is a very acceptable condition for the majority of sound shots where the character of the pictorial background against which the principals are being photographed is such as to permit a small amount of traffic or other sound-effect noise of a mechanical nature. It becomes a limiting factor only in the few instances where the shot is one calling for almost complete silence, as in a forest or desert scene, and where at the same time the dialog is very intimate or low in level.

At higher speeds the noise is correspondingly higher and is produced primarily by the belt as it slides over the floor, so that apparently there is nothing further to be done about it. Fortunately these higher speeds ordinarily are used in scenes in which people are running or are excited, and are speaking with considerable energy, so that appreciably more noise from the treadmill may then be tolerated without impairment of the illusion created.

REMARKS BY THE PRESIDENT AT THE OPENING OF THE ATLANTIC CITY CONVENTION

(APRIL 22, 1940)

It seems to me that we are holding our meeting at a rather unusual and spectacular time in the history of the motion picture industry. Just at this moment a lot of the preparation for television is about to come to fruition. Sets for home service are on sale. There has been some criticism about the method of promoting the sale of sets, but I imagine that will be straightened out satisfactorily to all concerned before long.

It does bring very acutely to the attention of all of us the fact that television, with all its fears and hopes, is with us. I understand that large-screen television on a full-size screen, whatever that is, is also available, if, when, and as it seems proper to put it into use. In saying a "full-size" screen, I am always curious as to whether they mean a 14-foot screen in a small theater or the screen in Radio City Music Hall, for example.

Many of us were given the privilege of hearing demonstrated publicly three-dimensional sound recording (with enhancement). I thought the three-dimensional reproduction was very good. It is a marvelous technical achievement, and I am sure will find its place in the motion picture theater and elsewhere. I understand there are other three-dimensional sound systems about ready for commercial exploitation also, but I have not had the pleasure of hearing those.

There are also greatly improved lens systems today. Those of you who have seen the picture *Gone with the Wind* in the theaters where it was first shown know that all the projection lenses were the new Bausch & Lomb lenses, treated to eliminate surface reflection. Those same principles are being applied to photographic camera lenses and the resulting speed of the photography, as well as increased screen light, when used for projection lenses, is very noticeable.

There are also new developments in light-sources, both for studio and projection purposes, which have made available now to the very smallest theater the high-intensity type of light at a price they can afford to pay. So there is really no longer any excuse today for any

theater's not having a screen brightness and quality of illumination such as would be recommended by this Society.

The question of a standard for screen illumination comes up for discussion quite frequently. Naturally, as engineers, we would like to see it raised to a level where illuminating engineers believe it ought to be. There has been some hesitation to do this because of the lack of commercial possibilities of attaining such levels in many cases before. But I think today the only reason that these would not be obtainable in any theater is a matter of the volition of the owner of that theater.

All these things combined are going to have a great deal of effect on motion picture photography—faster films, faster lenses, more intense light-sources.

Our industry is not a static industry. I have heard some comments that the moving picture industry has reached its zenith and from now on we could expect that it would be on the decline. I don't know why anyone should get that impression. Nothing of which I know would lead me to feel that way about it. Certainly, there will be more competition for the public's attention in entertainment. But you have had that for years in radio, and I still do not believe that a televised picture in your own home compares in entertainment value with that on the theater screen. I am expressing my personal opinion.

The research which is going on continually in the laboratories of the equipment manufacturers, and the technical advances in methods and equipment being made by the technicians in the studios themselves, lead me to look forward with a great deal of confidence to the future of this motion picture industry. The only thing I can see that will hold up progress would be if we should become more definitely involved in the world chaos than we now are; and I think I speak for all the members of our Society in hoping that, somehow or other, we may be spared the autocracy that is bound to come with our formal participation in such a war.

E. ALLAN WILLIFORD,
President

CURRENT LITERATURE OF INTEREST TO THE MOTION PICTURE ENGINEER

The editors present for convenient reference a list of articles dealing with subjects cognate to motion picture engineering published in a number of selected journals. Photostatic copies may be obtained from the Library of Congress, Washington, D. C., or from the New York Public Library, New York, N. Y. Micro copies of articles in magazines that are available may be obtained from the Bibliofilm Service, Department of Agriculture, Washington, D. C.

Acoustical Society of America, Journal

11 (April, 1940), No. 4

- The Genesis of Absolute Pitch (pp. 434-439) A. BACHEM
Graphical Determination of the Random Efficiency of
Microphones (pp. 477-479) B. BAUMZWEIGER

American Cinematographer

21 (March, 1940), No. 3

- Non-Glare Coating Makes Lenses One Stop Faster
(pp. 108-109, 142) W. STULL
Sequences Are the Heartbeat of Travelogues (pp.
111-114) C. W. HERBERT
Handicaps Against India's Film Production (pp. 115-
116), Pt. II F. BERKO
Making Titles That Will Stand Up (pp. 117-118) J. SHERLOCK
Studying Photoelectric Exposure Metering (pp.
119-120) D. NORWOOD
Securing Required Light on Outdoor Pictures (pp.
134, 141) C. W. CADARETTE

21 (April, 1940), No. 4

- Mitchell Blimpless Cameras Really Silent (pp. 166-
167) W. STULL
There's Fun in Using a Filter: If It's Used Rightly
(pp. 175-176, 185) C. W. CADARETTE
In Framing Your Picture Composition Search for
Lines (pp. 178-179) J. A. SHERLOCK
Victor's New Equipment for Its 16-Mm Projectors
(p. 189)

21 (May, 1940), No. 5

- Ed Harrison Watches Birds Grow Up (pp. 199-201)
How Small Lamps Are Being Used on Major Sets
(pp. 202-203) W. STULL
Commercials as They Were—and as They Are Today
(pp. 208-209, 237-238) C. W. HERBERT

- Treatment of Camera Lenses with Low Reflecting Films (pp. 215-218) C. H. CARTWRIGHT
 Kodachrome Filming Presents More Problems (pp. 224, 232) C. W. CADARETTE
- British Journal of Photography**
 87 (February 16, 1940)
 Progress in Color (pp. 77-79) 87 (April 5, 1940)
 Progress in Color (pp. 167-168) 87 (April 12, 1940)
 Progress in Color (pp. 180-181) 12 (April, 1940)
 Factory Methods Come to Pictures (pp. 11, 24) W. DRAPER
 12 (May, 1940)
 Camera Cavalcade (pp. 5-8) L. SHAMROY
- International Projectionist**
 15 (February, 1940), No. 2
 Arcs—Their Operation and Light Output (pp. 7-8, 11) W. E. FORSYTHE
 Instrument for the Reduction of Flutter (pp. 12, 15) R. J. KOWALSKI
 The Orthicon, A Television Pick-Up Tube (pp. 16, 19-21) A. ROSE AND H. IAMS
 Push-Pull Ultraviolet Recording (pp. 23-24) 15 (March, 1940), No. 3
 Types of Sound-on-Film Recordings (pp. 7-8, 11)
 Distortion Often Caused by Defective Tube in Push-Pull Power Stage (p. 12)
 Air-Cooled High-Brightness Mercury Vapor Lamps for Motion Picture Projection (pp. 15-16, 19-20)
 New Brenkert "Senarc" Intermediate H-I Arc Lamp (pp. 22-23) K. BRENKERT
- Motion Picture Herald**
 139 (May 4, 1940), No. 5
 Finch, Facsimile Inventor, Sees Medium as New Aid to Publicity (p. 52)
- Philips Technical Review**
 5 (March, 1940), No. 3
 The Transport of Sound Film in Apparatus for Recording and Reproduction (pp. 74-81) J. J. C. HARDENBERG
- RCA Review**
 4 (April, 1940), No. 4
 Television Studio Technic (pp. 399-413) A. W. PROTZMAN
 Television Lighting (pp. 414-424) W. C. EDDY
 Selective Side-Band Transmission in Television (pp. 425-440) R. D. KELL AND G. L. FREDENDALL

British Kinematograph Society, Journal

3 (January, 1940), No. 1

Volume Compression in Sound Recording (pp. 3-11) M. F. COOPER

The Electrical Reduction Method of Producing Sub-standard Sound Tracks (pp. 12-20)

N. LEEVERS

Reversal Processing of Sound Recordings (pp. 21-32)

R. GORISCH

The "Microsound" Optical Reduction Printer (pp. 33-35)

Kinematograph Target Equipment for Military Training Purposes (pp. 36-37)

3 (April, 1940), No. 2

Presidential Address (pp. 53-55)

A. G. D. WEST

Colour and the Cameraman (pp. 70-81)

M. V. HOARE

The Co-Relation of Photo-Electric Exposure Meters (pp. 82-83)

M. F. COOPER

The Directional Effect in Machine Development (pp. 84-92)

B. C. SEWELL

Communications

20 (April, 1940), No. 4

Fundamentals of Television Engineering (pp. 19-21, 36-37)

F. ALTON EVEREST

A Light-Pattern Calibration Chart (pp. 24-26)

A. J. EBEL

Electronics

13 (March, 1940), No. 3

Acoustic Line Loudspeakers (pp. 30-33)

W. D. PHELPS

Vented Speaker Enclosure (pp. 34, 54-55)

Electronics and Television and Short-Wave World

13 (March, 1940), No. 145

Photographing Television Programmes (p. 124)

13 (April, 1940), No. 146

Some Theoretical and Practical Aspects of Photo-electric Cells (pp. 149-152)

VACUUM SCIENCE
PRODUCTS, LTD.

A New 80-Watt Fluorescent Discharge Tube (p. 152)

Measurement of Transmitting Valve Characteristics Above the Dissipation Limit (pp. 153-156)

G. STOLZER AND J. A.
SARGROVE

Barrier-Layer Photo-Cells for Substandard Talkies (p. 159)

International Photographer

12 (March, 1940), No. 2

The Theory of 3-Color Photography (pp. 5, 27-28), Pt. I

KEVA MARCUS

1940 FALL CONVENTION

SOCIETY OF MOTION PICTURE ENGINEERS

HOLLYWOOD ROOSEVELT HOTEL HOLLYWOOD, CALIFORNIA
OCTOBER 21ST-25TH, INCLUSIVE

Arrangements for the 1940 Fall Convention in Hollywood are now being made and a complete list of the Convention committees will be announced in the next issue of the JOURNAL.

Headquarters

Headquarters of the Convention will be in the Hollywood Roosevelt Hotel. Excellent accommodations are assured to those registering early. Special hotel rates, guaranteed to SMPE delegates, European plan, will be announced in the next issue of the JOURNAL.

Indoor and outdoor garage facilities adjacent to the Hotel will be available to those who motor to the Convention.

Members and guests of the Society will be expected to register immediately upon arriving at the Hotel. Convention badges and identification cards will be supplied which will be required for admittance to the various sessions, the studios, and several Hollywood motion picture theaters.

Railroad Fares

The following table lists the railroad fares and Pullman charges:

<i>City</i>	<i>Railroad Fare (round trip)</i>	<i>Pullman (one way)</i>
Washington	\$132.20	\$22.35
Chicago	90.30	16.55
Boston	135.00	23.65
Detroit	106.75	19.20
New York	135.00	22.85
Rochester	124.05	20.50
Cleveland	111.00	19.20
Philadelphia	135.00	22.35
Pittsburgh	117.40	19.70

The railroad fares given above are for round trips. Arrangements may be made with the railroads to take different routes going and coming, if so desired, but once the choice is made it must be adhered to, as changes in the itinerary may be effected only with considerable difficulty and formality. Delegates should consult their local passenger agents as to schedules, rates, and stop-over privileges.

Technical Sessions

The Hollywood meeting always offers our membership an opportunity to become better acquainted with the studio technicians and production problems, and arrangements will be made to visit several of the studios. The Local Papers Committee under the chairmanship of Mr. L. A. Aicholtz is collaborating closely with the General Papers Committee in arranging the details of the program. Complete details of the program will be published in a later issue of the JOURNAL.

Studio Visits

Arrangements are being made for visits to several studios. Details will be announced in a later issue of the JOURNAL.

Semi-Annual Banquet and Dance

The 47th Semi-Annual Banquet of the Society will be held at the Hotel on Wednesday, October 23rd. Addresses will be delivered by prominent members of the industry, followed by dancing and entertainment. The Progress Medal and Journal Award of the Society will be given at the Banquet.

New Equipment Exhibit

An exhibit of newly developed motion picture equipment will be held in the Bombay and Singapore Rooms of the Hotel, on the mezzanine. Those who wish to exhibit their equipment in this exhibit should communicate as early as possible with the general office of the Society at the Hotel Pennsylvania, New York, N. Y.

Ladies' Program

An especially attractive program for the ladies attending the Convention is being arranged by Mrs. L. L. Ryder, *hostess*, and the Ladies' Committee. A suite will be provided in the Hotel, where the ladies will register and meet for the various events upon their program. Further details will be published in a succeeding issue of the JOURNAL.

Points of Interest

En route: Boulder Dam, Las Vegas, Nevada; and the various National Parks.

Hollywood and vicinity: Beautiful Catalina Island; Zeiss Planetarium; Mt. Wilson Observatory; Lookout Point, on Lookout Mountain; Huntington Library and Art Gallery (by appointment only); Palm Springs, Calif.; beaches at Ocean Park and Venice, Calif.; famous old Spanish missions; Los Angeles Museum (housing the SMPE motion picture exhibit); Mexican village and street, Los Angeles.

In addition, numerous interesting side trips may be made to various points throughout the West, both by railroad and bus. Among the bus trips available are those to Santa Barbara, Death Valley, Agua Caliente, Laguna, Pasadena, and Palm Springs, and special tours may be made throughout the Hollywood area, visiting the motion picture and radio studios.

SOCIETY ANNOUNCEMENTS

ATLANTIC COAST SECTION

At a meeting held at the Hotel Pennsylvania, New York, N. Y., on May 15th, Mr. G. T. Lorance of Electrical Research Products, Inc., presented a paper on the "Signal-to-Noise Ratio in Recording Methods and Technic." In his presentation Mr. Lorance discussed the quest for a higher signal-to-noise ratio and described the various types of sound-track employed, both variable-density and variable-area.

The meeting was well attended and an interesting discussion followed the presentation.

MID-WEST SECTION

On April 30th at the meeting rooms of the Western Society of Engineers Mr. M. Townsley, of the Bell and Howell Company of Chicago, presented a paper dealing with the "Elementary Theory and History of Lens Surface Treatment."

The presentation embodied a short but detailed history of lens "plating" processes, beginning with the experiments of H. Dennis Taylor with hydrogen sulfide in 1892. The work was traced through Kollmorgen in 1916 and F. E. Wright's experiments in 1917. The paper concluded with a description of the work of John Strong, of the California Institute of Technology, who, in 1936, described a method involving the evaporation of metallic fluorides *in vacuo* giving the same effect as the chemical method. The work of Dr. Katherine Blodgett, of the General Electric Company, was also discussed and analyzed.

On May 28th Mr. H. S. Knowles, of the Jensen Radio Manufacturing Company in Chicago, presented a talk on the subject of "Theater Speaker Design Trend." In the presentation Mr. Knowles discussed the influences of the permanent magnet, modern theater design, and fine-grain emulsion upon the design of loud speakers and on stereophonic reproduction.

JOURNAL
OF THE SOCIETY OF
MOTION PICTURE ENGINEERS



AUTHOR AND CLASSIFIED
INDEXES

VOLUME XXXIV
JANUARY-JUNE, 1940

AUTHOR INDEX, VOLUME XXXIV

JANUARY TO JUNE, 1940

<i>Author</i>		<i>Issue Page</i>
ATKINSON, R. B. (and SHANER, V. C.)	Chemical Analysis of Photographic Developers and Fixing Baths	May 485
BACK, F. G. (and EHRENHAFT, F.)	A Non-Intermittent Motion Picture Projector	Feb. 223
BARNETT, H. (and FRIEDL, G., JR., and SHORTT, E. J.)	A New High-Quality Sound System	Feb. 212
BEGGS, J. S. (and CAPSTAFF, J. G.)	Film Splicer for Developing Machines	Mar. 339
BORBERG, W. (and PIRNER, E.)	Simplex Double-Film Attachment	Feb. 219
CAPSTAFF, J. G. (and BEGGS, J. S.)	Film Splicer for Developing Machines	Mar. 339
CLEMENGER, J. F. (and WOOD, F. C.)	Sixteen-Mm Equipment and Practice in Commercial Film Production	June 555
COOK, H. R., JR. (and ROBERTS, F. W.)	A Sound-Track Center-Line Measur- ing Device	Jan. 38
CRABTREE, J. I. (and SCHWINGEL, C. H.)	Effect of Aeration on the Photo- graphic Properties of Developers	Apr. 375
DAILY, C. R.	Improvement in Sound and Picture Release through the Use of Fine- Grain Film	Jan. 12
DEMBER, A. (and GOETZ, A., and GOULD, W. O.)	The Objective Measurement of the Graininess of Photographic Emul- sions	Mar. 279
DREW, R. O. (and KELLOGG, E. W.)	Starting Characteristics of Speech Sounds	Jan. 43
DUDLEY, H.	The Vocoder—Electrical Re-Creation of Speech	Mar. 272
EATON, W. W. (and FULLER, A. B.)	A Flexible Time-Lapse Outfit	Mar. 334
EHRENHAFT, F. (and BACK, F. G.)	A Non-Intermittent Motion Picture Projector	Feb. 223
FLETCHER, H.	Stereophonic Reproduction from Film	June 606
FRAYNE, J. G. (and PAGLIARULO, V.)	The Effects of Ultraviolet Light on Variable-Density Recording and Printing	June 614

<i>Author</i>		<i>Issue Page</i>
FRIEDL, G., JR. (and BARNETT, H., and SHORTT, E. J.)	A New High-Quality Sound System	Feb. 212
FULLER, A. B. (and Eaton, W. W.)	A Flexible Time-Lapse Outfit	Mar. 334
Goetz, A. (and GOULD, W. O., and DEMBER, A.)	The Objective Measurement of the Graininess of Photographic Emul- sions	Mar. 279
GOLDSMITH, A. N.	Future Development in the Field of the Projectionist	Feb. 131
GOODMAN, A. (and KOWALSKI, R. J., and HARDMAN, W. F., and STANKO, W. S.)	Safeguarding Theater Sound Equip- ment with Modern Test Instru- ments	Apr. 409
GORDON, I.	Defects in Motion Picture Projection and Their Correction	June 596
GOULD, W. O. (and GOETZ, A., and DEMBER, A.)	The Objective Measurement of the Graininess of Photographic Emul- sions	Mar. 279
HARDMAN, W. F. (and GOODMAN, A., and KOWALSKI, R. J., and STANKO, W. S.)	Safeguarding Theater Sound Equip- ment with Modern Test Instru- ments	Apr. 409
HARGROVE, F. H. (and OFFENHAUSER, W. H., JR.)	Some Industrial Applications of Cur- rent 16-Mm Sound Motion Picture Equipment	Feb. 156
HASKIN, B.	The Development and Practical Ap- plication of the Triple-Head Back- ground Projector	Mar. 252
HOLCOMB, A. L.	A Multiduty Motor System	Jan. 103
HOLMES, L. B. (and WOLF, S. K.)	The Resonoscope	May 534
HOVER, T. P.	A Personal Safety Factor for Pro- jection Practice	June 589
IVES, C. E. (and KUNZ, C. J.)	Solution Agitation by Means of Com- pressed Air	Apr. 364
JOY, D. B. (and LOZIER, W. W., and SIMON, R. W.) (and LOZIER, W. W.)	Large Size Non-Rotating High-Inten- sity Carbons and Their Application to Motion Picture Projection	Mar. 241
	A Carbon Arc for Projection of 16-Mm Film	June 575
KELLOGG, E. W. (and DREW, R. O.)	Starting Characteristics of Speech Sounds	Jan. 43
KINGSLAKE, R.	Lenses for Amateur Motion Picture Equipment	Jan. 76

<i>Author</i>		<i>Issue Page</i>
KOWALSKI, R. J. (and GOODMAN, A., and HARDMAN, W. F., and STANKO, W. S.)	Safeguarding Theater Sound Equip- ment with Modern Test Instru- ments	Apr. 409
KUNZ, C. J. (and IVES, C. E.)	Solution Agitation by Means of Com- pressed Air	Apr. 364
LEONARD, R. S.	A Reel and Tray Developing Machine	Feb. 168
LOZIER, W. W. (and JOY, D. B., and SIMON, R. W.) (and JOY, D. B.)	Large Size Non-Rotating High-Inten- sity Carbons and Their Application to Motion Picture Projection A Carbon Arc for Projection of 16-Mm Film	Mar. 241 June 575
MORIN, E. R.	Projection Room Planning for Safety	Feb. 134
OFFENHAUSER, W. H., JR. (and HARGROVE, F. H.)	Some Industrial Applications of Cur- rent 16-Mm Sound Motion Picture Equipment	Feb. 156
PAGLIARULO, V. (and FRAYNE, J. G.)	The Effects of Ultraviolet Light on Variable-Density Recording and Printing	June 614
PETERS, T. K.	The Preservation of History in the Crypt of Civilization	Feb. 206
PIRNER, E. (and BORBERG, W.)	Simplex Double-Film Attachment	Feb. 219
PRATER, J. R.	The Projectionist's Part in Main- tenance and Servicing	Feb. 143
REICHES, S. L.	Records for the Projection Room	June 601
RETINGER, M.	Volume Distortion Motion Picture Theater Develop- ments	Jan. 59 May 524
RICHARDSON, F. H.	Possible Methods for Encouraging Study by Projectionists	Feb. 154
ROBBINS, J. E.	Silent Variable-Speed Treadmill	June 632
ROBERTS, F. W. (and COOK, H. R., JR.)	A Sound-Track Center-Line Measur- ing Device	Jan. 38
ROBERTS, F. W. (and TAENZER, E.)	Photographic Duping of Variable- Area Sound	Jan. 26
ROGER, H.	Science and the Motion Picture	Feb. 193
RUBIN, H.	Projection Supervision, Its Problems and Its Importance	June 580
RYDER, L. L.	The Importance of Cooperation be- tween Story Construction and Sound to Achieve a New Personal- ity in Pictures	Jan. 98
SCHLANGER, B.	Motion Picture Auditorium Lighting The Projectionist's Interest in Audi- torium Viewing Conditions	Mar. 259 June 585

<i>Author</i>		<i>Issue Page</i>
SCHWINGEL, C. H. (and CRABTREE, J. I.)	Effect of Aeration on the Photographic Properties of Developers	Apr. 375
SEELEY, E. S.	Considerations Relating to Warbled Frequency Films	Feb. 177
SEELEY, E. S.	The Adjustable Equalizer as a Tool for Selecting Best Response Characteristics	Apr. 351
SHANER, V. C. (and ATKINSON, R. B.)	Chemical Analysis of Photographic Developers and Fixing Baths	May 485
SHORTT, E. J. (and FRIEDL, G., JR., and BARNETT, H.)	A New High-Quality Sound System	Feb. 212
SIMON, R. W. (and JOY, D. B., and LOZIER, W. W.)	Large Size Non-Rotating High-Intensity Carbons and Their Application to Motion Picture Projection	Mar. 241
STANKO, W. S. (and GOODMAN, A., and HARDMAN, W. F., and KOWALSKI, R. J.)	Safeguarding Theater Sound Equipment with Modern Test Instruments	Apr. 409
SULZER, A. F.	The Epoch of Progress in Film Fire Prevention	Apr. 398
TAENZER, E. (and ROBERTS, F. W.)	Photographic Duping of Variable-Area Sound	Jan. 26
THOMPSON, L.	Direct 16-Mm Production	June 565
TUTTLE, F.	Automatic Slide Projectors for the New York World's Fair	Mar. 265
WILLIFORD, E. A.	Remarks by the President at the Opening of the Atlantic City Convention	June 637
WOLF, S. K. (and HOLMES, L. B.)	The Resonoscope	May 534
WOOD, F. C. (and CLEMENGER, J. F.)	Sixteen-Mm Equipment and Practice in Commercial Film Production	June 555

CLASSIFIED INDEX, VOLUME XXXIV

JANUARY TO JUNE, 1940

Acoustics

Considerations Relating to Warbled Frequency Films, E. S. Seeley, No. 2 (Feb.), p. 177.

Motion Picture Theater Developments, M. Rettinger, No. 5 (May), p. 524.

Address

Remarks by the President at the opening of of the Atlantic City Convention, E. A. Williford, No. 6 (June), p. 637.

Apparatus

A Sound-Track Center-Line Measuring Device, F. W. Roberts and H. R. Cook, Jr., No. 1 (Jan.), p. 38.

A Multiduty Motor System, A. L. Holcomb, No. 1 (Jan.), p. 103.

A New High-Quality Sound System, G. Friedl, Jr., H. Barnett, and E. J. Shortt, No. 2 (Feb.), p. 212.

Simplex Double-Film Attachment, W. Borberg and E. Pirner, No. 2 (Feb.), p. 219.

A Non-Intermittent Motion Picture Projector, F. Ehrenhaft and F. G. Back, No. 2 (Feb.), p. 223.

A Flexible Time-Lapse Outfit, A. B. Fuller and W. W. Eaton, No. 3 (March), p. 334.

Film Splicer for Developing Machines, J. G. Capstaff and J. S. Beggs, No. 3 (March), p. 339.

The Adjustable Equalizer as a Tool for Selecting Best Response Characteristics, E. S. Seeley, No. 4 (April), p. 351.

Safeguarding Theater Sound Equipment with Modern Test Instruments, A. Goodman, R. J. Kowalski, W. F. Hardman, and W. S. Stanko, No. 4 (April), p. 409.

The Resonoscope, S. K. Wolf and L. B. Holmes, No. 5 (May), p. 534.

Silent Variable-Speed Treadmill, J. E. Robbins, No. 6 (June), p. 632.

Applied Motion Picture Photography

Some Industrial Applications of Current 16-Mm Sound Motion Picture Equipment, W. H. Offenhauser, Jr., and F. H. Hargrove, No. 2 (Feb.), p. 156.

Science and the Motion Picture, H. Roger, No. 2 (Feb.), p. 193.

Arcs

Large Size Non-Rotating High-Intensity Carbons and Their Application to Motion Picture Projection, D. B. Joy, W. W. Lozier, and R. W. Simon, No. 3 (March), p. 241.

A Carbon Arc for Projection of 16-Mm Film, W. W. Lozier and D. B. Joy, No. 6 (June), p. 575.

Background Projection

The Development and Practical Application of the Triple-Head Background Projector, B. Haskin, No. 3 (March), p. 252.

Committees of the Society

No. 4 (April), p. 427.

Committee Reports

Standards, No. 1 (Jan.), p. 88.

Studio Lighting, No. 1 (Jan.), p. 94.

Projection Practice, No. 2 (Feb.), p. 125.

Progress

Progress in the Motion Picture Industry, No. 5 (May), p. 455.

Current Literature

No. 1 (Jan.), p. 114; No. 2 (Feb.), p. 232; No. 3 (March), p. 342; No. 4 (April), p. 433; No. 5 (May), p. 539; No. 6 (June), p. 639.

Development, Photographic

A Reel and Tray Developing Machine, R. S. Leonard, No. 2 (Feb.), p. 168.

Solution Agitation by Means of Compressed Air, C. E. Ives and C. J. Kunz, No. 4 (April), p. 364.

Effect of Aeration on the Photographic Properties of Developers, J. I. Crabtree and C. H. Schwengel, No. 4 (April), p. 375.

Chemical Analysis of Photographic Developers and Fixing Baths, R. B. Atkinson and V. C. Shaner, No. 5 (May), p. 485.

Distortion

Volume Distortion, S. L. Reiches, No. 1 (Jan.), p. 59.

Film, Physical Characteristics

The Objective Measurement of the Graininess of Photographic Emulsions, A. Goetz, W. O. Gould, and A. Dember, No. 3 (March), p. 279.

Fire Protection

Projection Room Planning for Safety, E. R. Morin, No. 2 (Feb.), p. 134.

Regulations of the National Board of Fire Underwriters for the Storage and Handling of Nitrocellulose Motion Picture Film, No. 3 (March), p. 311.

The Epoch of Progress in Film Fire Prevention, A. F. Sulzer, No. 4 (April), p. 398.

General

The Importance of Coöperation between Story Construction and Sound to Achieve a New Personality in Pictures, L. L. Ryder, No. 1 (Jan.), p. 98.

Future Development in the Field of the Projectionist, A. N. Goldsmith, No. 2 (Feb.), p. 131.

The Projectionist's Part in Maintenance and Servicing, J. R. Prater, No. 2 (Feb.), p. 143.

- Possible Methods for Encouraging Study by Projectionists, F. H. Richardson, No. 2 (Feb.), p. 154.
- Science and the Motion Picture, H. Roger, No. 2 (Feb.), p. 193.
- The Preservation of History in the Crypt of Civilization, T. K. Peters, No. 2 (Feb.), p. 206.
- Automatic Slide Projectors for the New York World's Fair, F. Tuttle, No. 3 (March), p. 265.
- The Vocoder—Electrical Re-Creation of Speech, H. Dudley, No. 3 (March), p. 272.
- Regulations of the National Board of Fire Underwriters for the Storage and Handling of Nitrocellulose Motion Picture Film, No. 3 (March), p. 311.
- The Epoch of Progress in Film Fire Prevention, A. F. Sulzer, No. 4 (April), p. 398.
- Progress in the Motion Picture Industry, No. 5 (May), p. 455.

Historical

- The Preservation of History in the Crypt of Civilization, T. K. Peters, No. 2, (Feb.), p. 206.
- A Personal Safety Factor for Projection Practice, T. P. Hover, No. 6 (June), p. 589.
- Records for the Projection Room, J. R. Prater, No. 6 (June), p. 601.
- Remarks by the President at the Opening of the Atlantic City Convention, E. A. Williford, No. 6 (June), p. 637.

Index, Vol. XXXIV (Jan.—June, 1940)

- Author:* No. 6 (June), p. 646.
- Classified:* No. 6 (June), p. 650.

Industrial Motion Pictures

- Some Industrial Applications of Current 16-Mm Sound Motion Picture Equipment, W. H. Offenhauser, Jr., and F. H. Hargrove, No. 2 (Feb.), p. 156.

Instruments

- A Sound-Track Center-Line Measuring Device, F. W. Roberts and H. R. Cook, Jr., No. 1 (Jan.), p. 38.

Illumination in Projection

- Large Size Non-Rotating High-Intensity Carbons and Their Application to Motion Picture Projection, D. B. Joy, W. W. Lozier, and R. W. Simon, No. 3 (March), p. 241.

Illumination, Studio and Photographic

- Report of the Studio Lighting Committee, No. 1 (Jan.), p. 94.

Illumination in Theaters

- Motion Picture Auditorium Lighting, B. Schlanger, No. 3 (March), p. 259.

Lenses

- Lenses for Amateur Motion Picture Equipment, R. Kingslake, No. 1 (Jan.), p. 76.

Motors

A Multiduty Motor System, A. L. Holcomb, No. 1 (Jan.), p. 103.

Non-Intermittent Projection

A Non-Intermittent Motion Picture Projector, F. Ehrenhaft and F. G. Back, No. 2 (Feb.), p. 223.

Non-Theatrical Equipment

Lenses for Amateur Motion Picture Equipment, R. Kingslake, No. 1 (Jan.), p. 76.

Some Industrial Applications of Current 16-Mm Sound Motion Picture Equipment, W. H. Offenhauser, Jr., and F. H. Hargrove, No. 2 (Feb.), p. 156.

A Non-Intermittent Motion Picture Projector, F. Ehrenhaft and F. G. Back, No. 2 (Feb.), p. 223.

A Flexible Time-Lapse Outfit, A. B. Fuller and W. W. Eaton, No. 3 (March), p. 334.

Sixteen-Mm Equipment and Practice in Commercial Film Production, J. F. Clemenger and F. C. Wood, No. 6 (June), p. 555.

Direct 16-Mm Production, L. Thompson, No. 6 (June), p. 565.

A Carbon Arc for Projection of 16-Mm Film, W. W. Lozier, and D. B. Joy, No. 6 (June), p. 575.

Officers and Governors of the Society

In each issue of the JOURNAL, on the reverse of the Contents page. *Photos*, No. 4 (April), p. 424.

Optical

Lenses for Amateur Motion Picture Equipment, R. Kingslake, No. 1 (Jan.), p. 76.

Printing

Improvement in Sound and Picture Release through the Use of Fine-Grain Film, C. R. Daily, No. 1 (Jan.), p. 12.

The Effects of Ultraviolet Light on Variable-Density Recording and Printing, J. J. Frayne and V. Pagliarulo, No. 6 (June), p. 614.

Process Photography

The Development and Practical Application of the Triple-Head Background Projector, B. Haskin, No. 3 (March), p. 252.

Processing

A Reel and Tray Developing Machine, R. S. Leonard, No. 2 (Feb.), p. 168.

Solution Agitation by Means of Compressed Air, C. E. Ives and C. J. Kunz, No. 4 (April), p. 364.

Effect of Aeration on the Photographic Properties of Developers, J. I. Crabtree and C. H. Schwingel, No. 4 (April), p. 375.

Chemical Analysis of Photographic Developers and Fixing Baths, R. B. Atkinson and V. C. Shaner, No. 5 (May), p. 485.

Production of Motion Pictures

Sixteen-Mm Equipment and Practice in Commercial Film Production, J. F. Clemenger and F. C. Wood, No. 6 (June), p. 555.

Direct 16-Mm Production, L. Thompson, No. 6 (June), p. 565.

Progress

Progress in the Motion Picture Industry, No. 5 (May), p. 455.

The Epoch of Progress in Film Fire Prevention, A. F. Sulzer, No. 4 (April), p. 398.

Projection

Report of the Projection Practice Committee, No. 2 (Feb.), p. 125.

Future Development in the Field of the Projectionist, A. N. Goldsmith, No. 2 (Feb.), p. 131.

Projection Room Planning for Safety, E. R. Morin, No. 2 (Feb.), p. 134.

The Projectionist's Part in Maintenance and Servicing, J. R. Prater, No. 2 (Feb.), p. 143.

Possible Methods for Encouraging Study by Projectionists, F. H. Richardson, No. 2 (Feb.), p. 154.

A Non-Intermittent Motion Picture Projector, F. Ehrenhaft and F. G. Back No. 2 (Feb.), p. 223.

Large Size Non-Rotating High-Intensity Carbons and Their Application to Motion Picture Projection, D. B. Joy, W. W. Lozier, and R. W. Simon, No. 3 (March), p. 241.

The Development and Practical Application of the Triple-Head Background Projector, B. Haskin, No. 3 (March), p. 252.

Automatic Slide Projectors for the New York World's Fair, F. Tuttle, No. 3, (March), p. 265.

A Carbon Arc for Projection of 16-Mm Film, W. W. Lozier and D. B. Joy, No. 6 (June), p. 575.

Projection Supervision, Its Problems and Its Importance, H. Rubin, No. 6 (June), p. 580.

The Projectionist's Interest in Auditorium Viewing Conditions, B. Schlanger, No. 6 (June), p. 585.

A Personal Safety Factor for Projection Practice, T. P. Hover, No. 6 (June), p. 589.

Defects in Motion Picture Projection and Their Correction, I. Gordon, No. 6 (June), p. 596.

Records for the Projection Room, J. R. Prater, No. 6 (June), p. 601.

Safety in Projection

Projection Room Planning for Safety, E. R. Morin, No. 2 (Feb.), p. 134.

Regulations of the National Board of Fire Underwriters for the Storage and Handling of Nitrocellulose Motion Picture Film, No. 3 (March), p. 311.

The Epoch of Progress in Film Fire Prevention, A. F. Sulzer, No. 4 (April), p. 398.

A Personal Safety Factor for Projection Practice, J. P. Hover, No. 6 (June), p. 589.

Servicing Motion Picture Equipment

The Projectionist's Part in Maintenance and Servicing, J. R. Prater, No. 2 (Feb.), p. 143.

Safeguarding Theater Sound Equipment with Modern Test Instruments, A. Goodman, R. J. Kowalski, W. F. Hardman, and W. S. Stanko, No. 4 (April), p. 409.

Sixteen-Mm Equipment

Lenses for Amateur Motion Picture Equipment, R. Kingslake, No. 1 (Jan.), p. 76.

Some Industrial Applications of Current 16-Mm Sound Motion Picture Equipment, W. H. Offenhauser, Jr., and F. H. Hargrove, No. 2 (Feb.), p. 156.

A Non-Intermittent Motion Picture Projector, F. Ehrenhaft and F. G. Back, No. 2 (Feb.), p. 223.

A Flexible Time-Lapse Outfit, A. B. Fuller and W. W. Eaton, No. 3 (March), p. 334.

Sixteen-Mm Equipment and Practice in Commercial Film Production, J. F. Clemenger and F. C. Wood, No. 6 (June), p. 555.

Direct 16-Mm Production, L. Thompson, No. 6 (June), p. 565.

A Carbon Arc for Projection of 16-Mm Film, W. W. Lozier and D. B. Joy, No. 6 (June), p. 575.

Slide Projectors

Automatic Slide Projectors for the New York World's Fair, F. Tuttle, No. 3 (March), p. 265.

Sound Recording

Report on the Adaptation of Fine-Grain Films to Variable-Density Sound Technics, No. 1 (Jan.), p. 3.

Improvement in Sound and Picture Release through the Use of Fine-Grain Film, C. R. Daily, No. 1 (Jan.), p. 12.

Photographic Duping of Variable-Area Sound, F. W. Roberts and E. Taenzer, No. 1 (Jan.), p. 26.

A Sound-Track Center-Line Measuring Device, F. W. Roberts and H. R. Cook, Jr., No. 1 (Jan.), p. 38.

Volume Distortion, S. L. Reiches, No. 1 (Jan.), p. 59.

A Multiduty Motor System, A. L. Holcomb, No. 1 (Jan.), p. 103.

The Effects of Ultraviolet Light on Variable-Density Recording and Printing, J. G. Frayne and V. Pagliarulo, No. 6 (June), p. 614.

Sound Reproduction

Starting Characteristics of Speech Sounds, R. O. Drew and E. W. Kellogg, No. 1 (Jan.), p. 43.

Volume Distortion, S. L. Reiches, No. 1 (Jan.), p. 59.

Considerations Relating to Warbled Frequency Films, E. S. Seeley, No. 2 (Feb.), p. 177.

A New High-Quality Sound System, G. Friedl, Jr., H. Barnett, and E. J. Shortt, No. 2 (Feb.), p. 212.

- Simplex Double-Film Attachment, W. Borberg and E. Pirner, No. 2 (Feb.), p. 219.
- The Vocoder—Electrical Re-Creation of Speech, H. Dudley, No. 3 (March), p. 272.
- The Adjustable Equalizer as a Tool for Selecting Best Response Characteristics, E. S. Seeley, No. 4 (April), p. 351.
- Motion Picture Theater Developments, M. Rettinger, No. 5 (April), p. 524.
- The Resonoscope, S. K. Wolf and L. B. Holmes, No. 5 (May), p. 534.
- Stereophonic Reproduction from Film, H. Fletcher, No. 6 (June), p. 606.

Speech

- Starting Characteristics of Speech Sounds, R. O. Drew and E. W. Kellogg, No. 1 (Jan.), p. 43.
- The Vocoder—Electrical Re-Creation of Speech, H. Dudley, No. 3 (March), p. 272.

Splices

- Film Splicer for Developing Machines, J. G. Capstaff and J. S. Beggs, No. 3 (March), p. 339.

Standardization.

- Report of the Standards Committee, No. 1. (Jan.), p. 88.

Storage of Film

- Regulations of the National Board of Fire Underwriters for the Storage and Handling of Nitrocellulose Motion Picture Film, No. 3 (March), p. 311.

Studio Equipment

- Silent Variable-Speed Treadmill, J. E. Robbins, No. 6 (June), p. 632.

Studio Lighting

- Report of the Studio Lighting Committee, No. 1 (Jan.), p. 94.

Studio Practice

- The Importance of Coöperation between Story Construction and Sound to Achieve a New Personality in Pictures, L. L. Ryder, No. 1 (Jan.), p. 98.

Test-Films

- Considerations Relating to Warbled Frequency Films, E. S. Seeley, No. 2 (Feb.), p. 177.

Theater Design

- Motion Picture Theater Developments, M. Rettinger, No. 5 (May), p. 524.

Theater Lighting

- Motion Picture Auditorium Lighting, B. Schlanger, No. 3 (March), p. 259.

Time-Lapse Cinematography

- A Flexible Time-Lapse Outfit, A. B. Fuller and W. W. Eaton, No. 3 (March), p. 334.



